

# Design and Construction Standards

## Volume 7

# Underground Power Distribution Systems

July 1, 2018

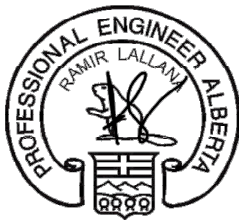

11 January 2022  
ID# 123547

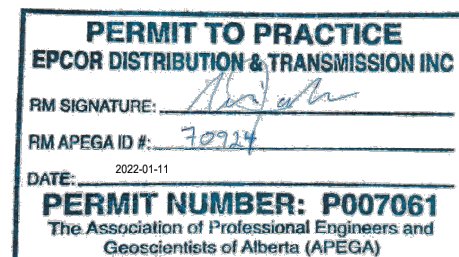

## Table of Contents

<b>1. GENERAL REQUIREMENTS</b> .....	<b>4</b>
1.1 Intent of these standards .....	4
1.2 Definitions .....	4
<b>2. DESIGN, APPROVALS, CCC, AND FAC</b> .....	<b>7</b>
2.1 Responsibility of the Developer .....	7
2.2 Trench/Excavation Design Requirements .....	7
2.3 Underground Industrial Development – Design (U.I.D.) .....	8
2.4 Underground Residential Development – Design (U.R.D.) .....	8
2.5 Underground Residential Development – Primary Cable .....	8
2.6 Underground Residential Development – Secondary Cable .....	9
2.7 Maximum Number of Services From A 1-Phase, 37 kVA Transformer .....	10
2.8 Power Layout Requirements – 1st Submission .....	10
2.9 Minimum Intended Design Clearances from EDTI Power Facility to Other Utilities, Street Furniture or Landscaping.....	11
2.10 Road Crossings.....	14
2.11 Service Stubs from Switching Cubicles .....	15
2.12 Cross Sections and Alignments.....	15
2.13 Pipeline Crossings and Pipeline Proximity Agreements.....	15
2.14 Railway Crossings.....	15
2.15 Transportation Utility Corridor (T.U.C.) Crossings .....	16
2.16 Other Crossings or Proximity agreements (EDTI or other utilities).....	16
2.17 Schematic Requirements.....	17
2.18 Drawing Submission / Approval process .....	17
2.19 Approved Power Drawing and Schematic .....	17
2.20 Construction Completion Certificates (C.C.C.)/Final Acceptance Certificates (F.A.C.):.....	17
2.21 Construction Cost Letter .....	17
2.22 Applying for Underground Residential Development (URD) lot rebates, Underground Industrial Development (UID) rebates and Feeder Rebates. ....	17
2.23 Damage to facilities.....	18
<b>3. TRENCHING, CABLING AND INSTALLATION OF BASES</b> .....	<b>19</b>
3.1 GENERAL REQUIREMENTS.....	19
3.2 Safety.....	20
3.3 Grades, Staking, Surveying and As-built .....	20
3.4 Trenching, Ducts, Troughs and Backfilling of Trenches .....	21
3.5 Road Crossings.....	23
3.6 Pipeline Crossings and Pipeline Proximity Agreements .....	24
3.7 Railway Crossings.....	24

3.8	<i>Transportation Utility Corridor (T.U.C.) Crossings</i> .....	25
3.9	<i>Other Crossings or Proximity agreements (EDTI or other utilities)</i> .....	25
3.10	<i>Cabling General Requirements</i> .....	26
3.11	<i>Protecting Cables using Temporary Transformer Bases</i> .....	26
3.12	<i>Protecting Cables Using Boarding and Shading</i> .....	27
3.13	<i>Protecting Cables Using Soil Bags</i> .....	27
3.14	<i>Secondary Services to Lots</i> .....	27
3.15	<i>Transformers</i> .....	28
3.16	<i>Switching Cubicles</i> .....	29
3.17	<i>Grounding and Bonding</i> .....	29
3.18	<i>Exposing Existing Power Facilities</i> .....	30
3.19	<i>Hydro Excavating Procedure (Hydrovac) over Primary or Secondary</i> .....	30
3.20	<i>Energized Primary</i> .....	31
3.21	<i>Primary Cable Splices</i> .....	31
3.22	<i>Splice Pits</i> .....	31
3.23	<i>Removing Temporary Transformer Bases</i> .....	31
3.24	<i>Installation of DA and AMI Equipment</i> .....	32
3.25	<i>Installation of Primary and Secondary Laterals</i> .....	32
3.26	<i>Cable Installation in Long Duct Segments or Manholes / Concrete-Encased Ducts</i> .....	32
<b>4.</b>	<b>TERMINATIONS / TERMINATION INSPECTIONS / CABLE, EQUIPMENT AND GROUND GRID TEST REPORTS</b> .....	<b>33</b>
4.1	<i>Safety</i> .....	33
4.2	<i>Prior to Terminations or Testing of Pad mounted Equipment</i> .....	33
4.3	<i>General Requirements for Pad mounted Equipment and Primary Terminations</i> .....	33
4.4	<i>Shaping, Termination and Identifying Cables in Transformers</i> .....	35
4.5	<i>Shaping and Terminations in 3-Phase Switching Cubicles</i> .....	36
4.6	<i>Shaping and Terminations in 1-Phase Switching Cubicles</i> .....	36
4.7	<i>Ground Grid Testing and Witnessing</i> .....	37
4.8	<i>Primary Cable Testing Requirements and Witnessing</i> .....	38
4.9	<i>General Cable Test Requirements</i> .....	38
4.10	<i>Equipment Testing Requirements and Witnessing</i> .....	38
4.11	<i>Upon Completion of Testing</i> .....	39

# 1. GENERAL REQUIREMENTS

## 1.1 Intent of these standards

The intent of these standards is to assist the developer with the design and installation of underground power distribution in an approved, consistent manner which conforms to the current City of Edmonton Design and Construction Standards, EPCOR Distribution and Transmission Inc.'s (EDTI) Construction Standards, Alberta Electrical Utility Code, CSA C22.3 – 7 Underground Systems and all other current applicable technical and safety standards. It is understood that these standards are subject to change and so, it is the developer's responsibility to work closely with EDTI and the City of Edmonton to ensure the most current standard is followed. In addition to the above mentioned requirements, in some cases EDTI will exceed these minimum standards.

The work defined in volume 7 relates to work to be done through a service agreement between the City of Edmonton and the developer of the subdivision. However, work being done on behalf of EDTI under arrangement with a developer or through a contractual arrangement between a contractor and EDTI will have similar expectations and so this book can be used for that purpose also.

## 1.2 Definitions

**5-party trenching** (also known as 4-party trenching): Where shallow utilities (power, street lighting, Telus, Shaw) in the same trench include natural gas. This is not a typical installation in the City of Edmonton.

**AEUC:** Alberta Electrical Utility Code, 5th Edition, 2016, and any amendments thereto

**Alberta Electrical Utility Safety Association Guide Code of Practice for Working in the Vicinity of Electrical Equipment (AEUSA):** A document created by the AEUSA as a guideline for workers to follow while working near power facilities.

**AMI:** (Advanced Metering Infrastructure) is a technology that EDTI is implementing which includes equipment that EDTI requires the Developer to install including; steel poles, wood poles, precast concrete bases, PVC conduit, lateral pipes and secondary power cables.

**APEGA:** Association of Professional Engineers and Geophysicists of Alberta.

**ASET:** Association of Science and Engineering Technology Professionals of Alberta.

**Base Plans:** Plans showing a minimum of proposed roads and property lines. More detailed base plans would include lot lines complete with lot numbers and block lines complete with block numbers.

**Certified Journeyman Powerline Technician or Power Systems Electrician:** A person who has a minimum of five years' related medium-voltage termination experience recognized in the province of Alberta as an Powerline Technician or Power Systems Electrician.

**City:** The Corporation of the City of Edmonton, the City of Edmonton's Planning and Development office or land which is in the City of Edmonton's control (i.e. City Boulevard).

**Consultant(s):** The company or corporation retained by the Developer to act and represent on its behalf and responsible for the design of the underground power distribution work, including, but not limited to, the other services (land survey, land agents, permitting, etc.).

**Consulting Engineer(s):** The Professional Engineer (P.Eng.), Professional Licensee (P.L.Eng.) and Professional Technologist (P.Tech.) registered and in good standing with the Association of Professional Engineers and Geophysicists of Alberta (APEGA) or the Association of Science and Engineering Technology Professionals of Alberta (ASET) entitled to engage in the practice of engineering who is responsible to the Developer for the design and authentication of the construction and installation of the power distribution system pursuant to the Service Agreement.

**Contractor:** The Company hired by the developer to install the underground power distribution, complete terminations or performs high voltage testing of cables, equipment or performing resistance tests. The developer is responsible for all workmanship and so where the word contractor is mentioned in this standard, it shall be understood that the developer is ultimately responsible.

**DA (Distribution Automation):** A technology EDTI is implementing that uses equipment EDTI requires the Developer to install, including steel poles, wood poles, precast concrete bases, PVC conduit and lateral pipes.

**Developer:** The owner of the land being developed under an approved City of Edmonton service agreement. The Developer is ultimately responsible for all workmanship and work practices on-site.

- EDTI:** EPCOR Distribution and Transmission Inc., the power distribution supply authority within the City of Edmonton referred to as EDTI.
- EDTI Land Servicing:** The group within EDTI who review the subdivision process, review drawings, approve drawings, review test reports issue work orders, review and record an as-built of the completed installation.
- EDTI Inspector:** The EDTI employee trained to inspect underground power distribution installations, including trenching, pushing, working over energized primary, cabling and base construction. The contact phone number is 780-412-4591.
- EDTI Splice Recording Sheet:** An EDTI form completed by the Contractor providing the required information for all primary voltage splices.
- EDTI Standard:** The EDTI document or announcement clarifying an accepted practice of construction (i.e. City of Edmonton Design and Construction Standards Volume 7, EDTI Standards, EDTI Construction Drawings, EDTI Specifications and also includes written announcements made using letters, emails or meetings held by EDTI representatives).
- EDTI System Plan:** A plan showing the routing of feeder cable, distribution cable and phasing. This plan includes existing cabling and proposed future cabling.
- EDTI Underground Distribution Standard:** The EDTI Underground Distribution Standard duly stamped and approved by an EDTI Professional Engineer, Professional Licensee or Professional Technologist. The title may also include Underground Distribution Standards or Underground Distribution Engineering Standards.
- Engineering Set of Drawings:** The engineered drawings designed and produced by the developer's consultant or by an authority for the purpose of construction of all facilities on the lands contained within the service agreement.
- Hydro Excavation (HydroVac):** An EDTI-approved non-mechanical and non-destructive excavation process. It combines pressurized water and a high flow of moving air to simultaneously excavate and vacuum up the resulting soil and water slurry. The slurry is held in a truck-mounted debris tank until it is disposed of. (Refer to the latest EDTI Operating Procedure EX04 – Excavate Power Cables and any amendments thereto).
- Looped Primary:** An EDTI system plan typically includes at least two sets of primary cables installed into an area which can provide for more than one power source thereby allowing options for feeding equipment from more than one source.
- Marker Ball:** An electronic marker system used to easily and accurately locate underground facilities, (e.g., a future EDTI asset). (Refer to EDTI Underground Distribution Standard #6300070017001.)
- OHSA of Alberta:** Occupational Health and Safety Act of Alberta 2013, and any amendments thereto.
- Pad Number:** An EDTI supplied number shown on the approved power plan and displayed on the outside of the switching cubicle or transformer.
- Power Plan:** The power distribution drawing which is intended to be approved by the City of Edmonton and by EDTI. If the plan has been red-lined then it should refer to the date that the original approved power plan has been signed off (approval date).
- Red-line:** When a deviation from the approved Power Plan is required, the deviation shall show in red (i.e., red line). Red-line revisions affecting alignments or equipment locations must be submitted and circulated as per the City of Edmonton Drawing Circulation Process. The changes shall have the date that the red-line change was completed in the legend and also indicate the date that the original approved Power Plan was signed off (approval date).
- Schematic:** The power distribution drawing is accompanied by a schematic showing the actual electrical connections to the equipment and is intended to be approved by the City of Edmonton and by EDTI. If the plan has been red-lined then it should refer to the date that the original approved power plan has been signed off (approval date).
- Shared Trench – No Gas (commonly referred to as 3-Party Trenching):** Location where shallow utilities (power, street lighting and communication cables/conduits) are installed in a common excavation typically 600 mm wide.
- Shared Trench – With Gas (commonly referred to as 4-Party or 5-Party Trenching):** Location where shallow utilities (power, street lighting and communications cables/conduits and natural gas) are installed in a common excavation typically 900 mm wide.
- Servicing Agreement:** An agreement between the land owner or Developer and the City of Edmonton that includes the terms and conditions for the development to proceed. The agreement will include the subdivision name and stage and define the boundaries of construction submitted to the City of Edmonton.
- Soil Bags:** Soil bags refer to woven bags manufactured specifically for soil or sand and used for covering cable. The size of bag is to be larger than what can normally be lifted manually.

**Underground Industrial Development:** (UID) Those areas which are zoned Industrial or commercial and have been indicated by EDTI to be built using underground power facilities. In some cases, there will be residential zoning included.

**Underground Residential Development:** (URD) Those areas which are a mixture of residential and commercial zoning that are to be built using underground power facilities.

**Vented Bushings:** A 25 kV primary bushing which has vented slots (all new installations must have vented bushings and “blue tags” to identify that they are vented bushings.

OBSOLETE

## 2. DESIGN, APPROVALS, CCC, AND FAC

### 2.1 Responsibility of the Developer

- 2.1.1 EDTI power distribution consists of looped primary systems which provide switching options, reliability and reduced outage times to customers. During the development of neighbourhoods EDTI will review the Developer submitted designs and determine what measures, if any, are required to allow the development of primary cable loops during initial and future stages of the neighbourhood. Measures that may be required can include
- Temporary aerial lines
  - Temporary underground lines
  - Additional underground primary distribution cable
  - Temporary or additional permanent 1-phase or 3-phase switching cubicles
  - Temporary utility rights-of-way for temporary equipment or cable alignments
  - Other measures to achieve the looping requirements identified by EDTI
- 2.1.2 It is the developer's responsibility to obtain an EDTI system plan prior to the design stage. This may include submission of updated base plans by the developer to EDTI Land Servicing for the purpose of preparing an overall EDTI system plan. In some cases, temporary facilities must be installed due to staging of construction at the developer's expense
- 2.1.3 The Power Plan and Schematic are to be included in a submission within the City of Edmonton's drawing approval process. These drawings will be part of the Engineering Set of Drawings submitted by the developer to EDTI's Land Servicing Manager.
- 2.1.4 EDTI distribution system typically consists of a 3-phase 15 kV or a 25 kV system. It is the Consultant's responsibility to find out what system is available in the area they are designing for.
- 2.1.5 It is the Developer's responsibility to supply and install all facilities identified by EDTI Land Servicing both in the Service Agreement and off-site facilities needed to feed the intended Service Agreement area. This may include modifications to existing facilities.
- 2.1.6 If a Developer wants to stage the construction of a development differently than indicated in an approved power distribution plan as submitted in the original subdivision request circulated by the City of Edmonton, the Developer shall submit the request to EDTI for review. EDTI will review the request and determine whether staging of the power distribution system will be allowed. Staging will typically only be allowed when the deep utilities or roadways are not completed due to seasonal limitations. Any additional costs to EDTI due to a staging plan approved after the original submission will be the responsibility of the Developer.
- 2.1.7 It is the Developer's responsibility to provide rights-of-way for any existing or proposed power facilities affected by the design not within the City of Edmonton road allowance.
- 2.1.8 Any modifications or relocations of existing power facilities may be at full cost to the Developer.
- 2.1.9 All power services to development entrance wall features must be metered services. No unmetered services will be allowed.

### 2.2 Trench/Excavation Design Requirements

- 2.2.1 The Developer has the option of installing the EDTI distribution system as a shared joint-use system with communications and street lighting cables/conduits (commonly referred to as 3-Party) or as a shared trench with communications, street lighting cable/conduits and natural gas pipe (commonly referred to as 4-Party or 5-Party). In this manual, the two options will be referred to as Shared Trench – No Gas or Shared Trench – with Gas. The Shared Trench – No Gas is typically installed in the space between curb and property line while the Shared Trench – With Gas is typically installed in a utility right-of-way. (Refer to Section 3.0 for details.)
- 2.2.2 Shared Trench – No Gas joint-use trenching has been used for many years in the City of Edmonton. Approved roadway cross-section drawings exist in Volume 2 – Roadways Design Standards / Construction Specification. The Developer and Consultant are expected to design to the approved cross-sections as per EDTI Underground Distribution Standard 6000070046001.

### 2.3 Underground Industrial Development – Design (U.I.D.)

- 2.3.1 The developer is responsible for the design, supply and installation of power facilities similar to the URD process. (Refer to Section 2.4 below.)
- 2.3.2 It is the developer's responsibility to obtain specific cable, cubicle and voltage requirements, from EDTI Land Servicing prior to designing the power distribution. There are a variety of electrical load densities in UID areas; contact EDTI Land Servicing to determine what cable and switching cubicles are required in the distribution system for your development.
- 2.3.3 All other design aspects are typically the same as Underground Residential Development.

### 2.4 Underground Residential Development – Design (U.R.D.)

- 2.4.1 These areas may contain 1-phase and 3-phase switching cubicles (15 kV or 25 kV), 1-phase transformers (8.3 kV (for the 15 kV system or 14.4 kV (for the 25 kV system) to 120/240 volt), distribution primary cables (typically 15 kV or 25 kV), and feeder cables (typically 15 kV or 25 kV). All new underground equipment is dead-front, where switching is done by EDTI using 200 amp load-break elbows or by ganged switches. For some developments, EDTI will require the installation of distribution automation switching cubicles. For these developments, the Contractor will be responsible for the installation of the switching cubicle and a 50 mm conduit from the switching cubicle location to the location of the EDTI-installed pole required for the radio antenna (refer to EDTI Underground Distribution Standard 6500071523030 for 15 kV distribution areas and 6500072523030 for 25 kV distribution areas. The Developer's Consulting Engineer will be required to provide a detail on the design drawings showing the installation and conduit.
- 2.4.2 Transformers and switching cubicles require 4 x 10-foot copper-clad electrodes and an interconnected grid using 19-strand #4/0 bare copper ground conductors complete with an additional two 19-strand #4/0 bare copper ground conductors (tails) terminating to the ground bus or ground plate on the electrical equipment. These grounding conductors are continuous without splicing. (Refer to EDTI Underground Distribution Standards 6500070060001, 6500071523132, 6500072523132, 6600070027115, 6600071523114 and 6600072523114.) All mechanical connections need to be torqued per manufacturer's specifications.
- 2.4.3 1-phase transformers will be 37 kVA complete with bayonet fusing.
- 2.4.4 There is one approved base size for minipad transformers in 15 kV or 25 kV areas. (Refer to EDTI Underground Distribution Standard 6600070027115.)
- 2.4.5 Transformers are of the feed-thru types which have two 200 amp elbow terminations and labelled "LA" and "LC" (see EDTI standard 6300070048006).
- 2.4.6 The secondary bushings of transformers must have a solid aluminum bus bar terminal block complete with Allen key set screws capable of terminating 4 AWG up to 350 MCM. An additional two set screws are for street lighting or communications services and are capable of terminating 4 AWG up to 3/0 AWG. (Refer to EDTI Underground Distribution Standards 6600071527015 and 6600072527015.)
- 2.4.7 As per CSA C22.3-7-15 clause 10.5, mechanical protection of pad-mounted equipment shall be considered when the location of the equipment leaves it vulnerable to damage.
- 2.4.8 Proposed switching cubicle and transformer locations must be offset from proposed bus pads by a minimum of 3.0 m. Switching cubicle and transformer utility rights-of-way are not to be behind proposed bus pads.
- 2.4.9 When requested by EDTI, the Consultant will be required to include EDTI's identified needs for Distribution Automation (DA) antennas and Advanced Metering Infrastructure (AMI) repeater equipment. This may include the design and installation of precast concrete streetlight bases, steel street light poles, conduits between identified pieces of equipment and power supply cable. (Refer to EDTI Underground Distribution Standards 6600070007001 and 6600070107001).

### 2.5 Underground Residential Development – Primary Cable

- 2.5.1 Primary cable requirements for distribution in Underground Residential Development will be 1/C # 1/0 AL XLPE Concentric Neutral Direct Buried cable with Tree Retardant (Refer to EDTI Underground Distribution Standard 6300070082001).
- 2.5.2 In some cases, the EDTI System Plan requires feeder cables larger than 1/0 primary cables. EDTI underground primary cable standards are cross-linked polyethylene (XLPE) concentric neutral direct-buried cable with tree retardant and or ethylene propylene rubber (EPR) concentric neutral direct-buried cable. (Refer to EDTI Underground Distribution Standard 6300070082001 for cable sizes and specifications.)
- 2.5.3 It is the Consulting Engineer's responsibility to find out what feeder cables may be required by the EDTI System Plan



- 2.5.4 Where multiple runs of primary are required in the same trench, there may be a need to de-rate the cable due to a mutual heating effect. Consult with EDTI Land Servicing for more details. If de-rating of the cable is not an option then separate trench alignment details are to be shown on the power plan to eliminate this mutual heating effect.
- 2.5.5 EDTI's preference is to minimize the number of primary cable splices within the distribution system. Primary splices will be allowed in the case of cable reel ends or damaged cable, or if the number of crossings dictates that it is more practical to provide a splice. The required cable splices are to be completed by EDTI as per Underground Distribution Standard 6300070048009 (Primary) and 6600070848011 (Secondary). All primary splice locations are to be shown on the as-built drawing and an EDTI Splice Recording Sheet completed and returned in the as-built package to EDTI. All splices to be completed by EPCOR.
- 2.5.6 Cables that are required to be buried greater than the standard depth require approval by EDTI Land Servicing. An engineering study may be required for non-standard cable burial depths that are not covered within the derating chart found in EDTI Underground Distribution Standard 6300070045002.

## 2.6 Underground Residential Development – Secondary Cable

- 2.6.1 Each residential service will be designed for a minimum 100 amps, 120/240 volt, 3-wire service. Services larger than 200 amps will need special consideration. Contact EDTI Land Servicing for more details. (Refer to EDTI Underground Distribution Standard 6300070082002.)
- 2.6.2 It is the developer's responsibility to consider the size of lot, size of house and therefore the need for a service size larger than 100 amps. Each residential service shall require an additional 30 m coil left on private property. The entire length of secondary for a residential service shall be installed without a splice. (Refer to Section 2.6.9 for details on future services.)
- 2.6.3 Service coils are to be installed in service boxes past the gas easement if one exists (Refer to Section 2.6.4 for side lots.)
- 2.6.4 A minimum of 3.0 m ("B" service) is required where the service enters the lot at the property line adjacent to a transformer. If space restrictions exist, consult Land Servicing Engineering..
- 2.6.5 Where side lots require servicing along the longer property line and there is a gas easement, service boxes (power service coils) are to be "A" services (1.5 m) from the rear property line or serviced from the front property line.
- 2.6.6 The service entry points will be 1.5 m ("A" service), 3.0 m ("B" service) or 4.5 m, ("C" service) from the lot line and must be installed parallel to the lot lines. Service entry points which are not designated as "A", "B" or "C" will be dimensioned on the power plan. Note the importance of front and rear lot pins staked to allow the installer to parallel the property line.
- 2.6.7 Secondary residential service cable is a minimum of 2/C #1/0 AL XLPE CN 600 V direct-buried type USEB90 cable. (Refer to EDTI Underground Distribution Standard 6300070082002.)
- 2.6.8 Where possible, transformers feeding future lot services should be located at near the edge of the construction boundary or stage.
- 2.6.9 When secondary services or streetlight wire(s) are planned to a future stage from a transformer that is not at the edge of the construction boundary, the secondary service cable(s) and streetlight wire(s) should be capped, and a 2.0 m coil extended into a temporary transformer base at the edge of the development or stage. The stubbed-out cables are to be labelled with white tape and a black permanent ink pen with lot and block numbers when available. If lot and block numbers are not available, cables shall be labelled A-A, B-B, etc. The stubbed-out service cable(s) will be spliced by EDTI or an EDTI-approved vendor when the future stage proceeds. Where known splices are planned in advance by the Consulting Engineer, the following should be indicated on the Power Plan: "To be spliced." The location of any additional splices required during construction is at the discretion of the EDTI Inspector and must meet EDTI Land Servicing approval.
- 2.6.10 Secondary voltage drop calculations shall conform with C22.1-12, Canadian Electrical Code, Part 1, 22nd Edition, 2012 - Section 8-102 and any amendments thereto, and are the responsibility of the Consulting Engineer and must be submitted upon request.
- 2.6.11 For nominal system voltages and recommended limits to voltage variations under normal and extreme operating conditions, refer to CAN-3-C235-83 (reaffirmed 2010) - Preferred Voltage Levels for AC Systems, 0–50,000 V and any amendments thereto.
- 2.6.12 Cable sizes must be shown on the plan in the legend or by some other method acceptable to EDTI Land Servicing. Acceptable secondary residential service cable sizes are single runs of 2/C 1/0, 2/0 and 4/0 AL USEB90. Any other arrangements must be approved by EDTI Land Servicing. (Refer to EDTI Underground Distribution Standard 6300070082002.)

**2.7** Maximum Number of Services From A 1-Phase, 37 kVA Transformer

Consult with EDTI Land Servicing for other arrangements. In addition to these residential services, two additional services for communications equipment or street lighting are acceptable.

Size of Service	kVA based on Service Size	# of Services	Minimum Cable Size (Al)	Cable length (m) Tx to SEP*
100A, 120V/240V	3	12	1/0	80
			2/0	110
			4/0	200
150A, 120V/240V	4	9	2/0	50
			4/0	110
200A, 120V/240V	6	6	4/0	70
Combination of the above service sizes		**		

\* SEP: Service Entry Point

\*\* Add up the total kVA of the services. The number of services that can be terminated cannot exceed 37 kVA

**2.8** Power Layout Requirements – 1st Submission

2.8.1 The power layout plan is to include all power distribution facilities inside the service agreement boundaries and outside of the service agreement boundaries where identified by EDTI. The electronic land base for drawings shall be:

Name: 3TM114-83  
 Description: NAD83 UTM, longitude, metres, Province of Alberta, Canada  
 Group: Canada  
 Projection: TM  
 Units: Metres

The following will be shown on the power layout or other drawing in the 1<sup>st</sup> submission:

- Name of subdivision.
- Stage number of subdivision.
- Drawing number.
- Scale.
- Revision block revised to show the number of submissions and the date of the submission.
- Date of the drawing.
- Lot lines and labels.
- Block lines and labels.
- Roads and labels including quadrant designation in the City of Edmonton (i.e. S.W.).
- References to existing stage numbers.
- Service entry point designation (i.e. A, B or C service).
- Legend indicating the symbology and their definitions.
- Gas layout.
- Gas crossings dimensioned to property lines.

- Gas easement.
- Other easement boundaries.
- Crossing dimensioned to property lines.
- Pad mounted equipment.
- Other above ground non-power equipment facilities.
- Details – hydrants
- Details – cross sections
- Power crossings (to be installed as per EDTI standards 6300070037002 and 6300070037001).
- Pipeline right of way crossings to be identified.
- Power easements identified.
- Size and number of ducts for service entry points identified and dimensioned from property line.
- Contactors for street lighting are to be identified and secondary shown back to the transformer.
- Communications power supplies are to be identified and secondary shown back to the transformer.
- A note box indicating the number and size of ducts to be capped for future, where ducts are stubbed to the next stage.
- If communications ducts are planned to be installed under EDTI equipment on easements on private property, a note must be added to the power plan indicating that a trough or ducts are to be installed and the alignment of that utility’s facilities on the detail (this will assist EDTI inspectors observing the work in the field and avoid confusion).
- For a Shared Trench – No Gas development, the primary cable shall be shown outside of the property lines (e.g., on road allowance) farthest away from property line
- For a Shared Trench – With Gas development, the primary cable shall be shown inside of property lines farthest away from property line
- For a Shared Trench – No Gas development, the secondary cable shall be shown outside of the property lines (e.g., on road allowance) closest to the property line
- Alignment box showing the alignment of the power trench
- For a Shared Trench – With Gas development, the secondary cable shall be shown inside of property lines closest to the property line
- Where EDTI has existing wood poles, all poles and pole numbers (EDTI Land Servicing will provide this information upon request)
- Any new wood poles proposed as part of the development.
- Where non EDTI systems are to be bonded to the EDTI system every 300 m, details must be shown on the power plan of where the connection is to be made and how the non EDTI systems are to be bonded.

2.9 Minimum Intended Design Clearances from EDTI Power Facility to Other Utilities, Street Furniture or Landscaping			
EDTI Facility	Utility, Furniture or Landscaping	Clearance	Notes
	Roadways (Volume 2)		
Transformer	Corner cut	6.0 m	
1-phase or 3-phase cubicle	Corner cut	30 m	
Transformer / Switching Cubicle	Bus Stop Pad	3.0 m	From edge of bus pad to edge of base

Transformer / Switching Cubicle	Road Crossing	3.0 m	From centre to closest duct in crossing
Pad-mounted equipment	Edge of walkway property line	3.0 m	From edge of equipment to edge of walkway property line
Pad-mounted equipment	Transportation control devices	3.0 m	From edge of pad
Power crossings	Bus stop pad	3.0 m	From edge of bus pad to crossing
Transformers	Driveways	2.0 m	From edge of equipment to driveway
Power crossings	Corner cuts	3.0 m	
	Drainage (Volume 3)		
Main Power Trench	Drainage/Sanitary Main Catch Basin Manhole, vault other larger drainage structure	2.0 m	Troughed to 1.5 m either side of catch basin if less than 2.0 m
1-phase pad-mounted equipment	Manhole, catch basin	4.5 m	3.0 m is required from the ground grid to the other utility
3-phase pad-mounted equipment	Manhole, catch basin	5.0 m	3.0 m is required from the ground grid to the other utility
Power crossings	Catch basin	3.0 m	Crossings in roadways must be 3.0 m from catch basins.
	Water (Volume 4)		
1-phase pad-mounted equipment, powerlines	Services, hydrants in the boulevard	4.5 m	3.0 m is required from the ground grid to the other utilities
Power crossing	Water (CC) service	1.8 m	Centre to centre
3-phase pad-mounted equipment	Services, hydrants in the boulevard	5.0 m	3.0 m is required from the ground grid to the other utility
Main Power Trench	Mains	3 m	Parallel
Main Power Trench	Hydrant	3 m	See EDTI Standard For Trenching Around Hydrants for reduced clearances
Primary or Secondary Cables	Service Valve	300 mm	Minimum distance when trenching past a service valve in the blvd. (i.e. curb cock, cc)
Power Service to lot	Service	1.8 m	Parallel to water service
Pad Mounted Equipment	Mains	3.0 m	

Pad Mounted Equipment	Valve Casings	1.0 m	1.5 m is required if another utility is already at 1.0 m or if crossed on both sides.
	Landscaping on City Property (Volume 5) <sup>5</sup>		
Main Power Trench	Trees	1.0 m	
3-phase switching cubicle	Trees, shrubs	3.0 m on each side where doors open	From edge of base.
Transformer	Trees, shrubs	2.0 m on sides 3.0 m in front of doors 1.5 m behind base	Measured from edge of base. Minimum 3.0 m of clearance in front of doors required for hot stick operation Measured from edge of base
Power Crossings	Trees	1.0 m	Measured horizontally offset from the power crossing alignment
Power Crossings	Landscaped Road Island		See Note 1 below
Pad Mounted Equipment	Landscaped Road Island		See Note 1 below
1-phase switching cubicle	Trees, shrubs	3.0 m front 4.0 m sides 2.5 m behind base	From Edge of base
	Street Lighting (Volume 6) – Common Trench		
Primary or Secondary cables	Street Light Davit Poles or Contactor	300 mm	See standard for trenching around street light pole bases
Power Crossing	Street Light Davit Poles or Contactor	1.5 m	To the closest power crossing duct
Pad Mounted Equipment	Main Street Light Trench	Common Trench	See base standards and trough standards
	I.P. Natural Gas line in Separate Trench		
Main Power Trench	Main	1.0 m	Parallel <sup>3</sup>
Power Crossing	Main	1.0 m	Parallel
Power Crossing	Main or Service	300 mm	Without mechanical separation <sup>4</sup>
Pad-mounted equipment	Gas crossing	3.5 m	From centre of equipment (minimum of 2.0 m from ground grid)
Pad-mounted equipment ground grid	Main gas trench	1.0 m	From ground grid to gas line trench
	Communications (Common Trench)		
Pad Mounted Equipment	Main Communications Trench	Common Trench	See base standards and trough standards

Pad Mounted Equipment	Communications Pedestals	3.0 m	Minimum 3.0 m from case of transformer or switching cubicle to case of pedestal. <sup>2</sup>
Primary or Secondary Cables	Communication Vault	300 mm	Minimum clearance between edge of communication vault and edge of primary or secondary.
Power crossing	To the closest power crossing duct	Power crossing	Communications equipment
	Pipeline Rights-of-Way (Other Than ATCO IP for Servicing the Subdivision)		
Pad-mounted equipment	From edge of right-of-way	10.0 m	From edge of pipeline right-of-way to edge of ground grid
Power crossings	From edge of right-of-way	5.0 m	Power crossing ducts perpendicular to pipelines are to be extended a minimum of 5.0 m from edge of right-of-way to end of crossing duct

These are preferred minimum horizontal clearances. Consult with EDTI Land Servicing for discussion of the possibility of any deviation to these approved clearances due to specific circumstances.

Clearances are from centre to centre of furniture, trench or duct unless otherwise noted.

Note 1: See the City of Edmonton Design and Construction Standards Volume 5 – Landscaping 5.13...shallow utilities shall not be placed in Landscaped Road Islands. Written permission for power crossings or pad mounted equipment in Landscaped Road Islands is the responsibility of the developer. Ducts must be continuous and cannot have trees within 1.0 m of the duct. Other plantings such as small shrubs or flowers would be allowed over top of the crossing.

Note 2: If communications pedestals are placed with 3.0 m from the edge of the ground grid of pad mounted power equipment, the two pieces of equipment will be bonded. A detail drawing is required.

Note 3: If it is mutually agreed that gas is in the same trench as power, refer to refer to EDTI Underground Distribution Standard 6000070046001 for the typical roadway cross-section to use.

Note 4: Where mutually agreed, an approved method of mechanical separation could be used to reduce the crossing from 300 mm (i.e. 5 Party Trenching, using a sleeve, fastened to the I.P. gas line, as mechanical separation and 100 mm of sand between the sleeve and the power cable.).

Note 5: Landscaping clearances are for work on City of Edmonton road allowances only. Landscaping clearances on EDTI utility rights-of-way (URW) are as per the URW documents.

## 2.10 Road Crossings

- 2.10.1 Up to 3 primary cables can be installed in one duct. The primary cables chosen to share the same duct must originate from the same set of switches (i.e. primary from an A1 switch could only be installed with primary from A1, A2 or A3 but not mixed with cable crossings from B1, B2 or B3). It is intended that primary cable be pulled through the duct as one pull where possible. Consideration will be given where cables are of different lengths.
- 2.10.2 Crossings at pad mounted equipment in City Boulevard (not on an easement) cannot be centre of the equipment.
- 2.10.3 Crossings near 1-phase switching cubicles and 1-phase transformers in the City Boulevard (not on an easement) must be a minimum of 2.5 meters from the centre of base.
- 2.10.4 Crossings near 3-phase switching cubicles and 3-phase transformers in the City Boulevard (not on an easement) must be a minimum of 3.0 meters from the centre of base.
- 2.10.5 Crossings are not allowed under proposed or existing bus pads. Crossings are to be a minimum of 3.0 m from the edge of the bus pad.

- 2.10.6 Where switching cubicles are installed in boulevards or on easements, the crossing ducts are continuous from the fused switch of any switching cubicle to the property line of the lot it is intended to service. The number of bends and length of duct must be considered so that recommended pulling tension of future cable is not exceeded. Road crossings should be centre of cubicle. A Red Marker Ball will be installed by the EDTI Inspector to identify the stub ends.
- 2.10.7 For service stubs, where switching cubicles are installed in boulevards or on easements, the road crossing ducts are continuous from the fused switch of any switching cubicle to the property line of the lot it is intended to service. A Red Marker Ball will be installed by the EDTI Inspector to identify the stub ends.
- 2.10.8 Crossings should always be aligned so that the power duct crosses the road at right angles (90 degrees), wherever possible.
- 2.10.9 Where more than one service cable is to be installed at a crossing the minimum duct size is 4 inch.
- 2.10.10 Crossing ducts are required under lanes and walkways.

### 2.11 Service Stubs from Switching Cubicles

- 2.11.1 There will be a bend installed for every compartment (i.e. 1 bend for "A", 1 bend for "B", etc.)
- 2.11.2 The ducts from each fused compartment to the property line that it is intended to service, will be continuous without breaks and capped at the property line. The duct will be identified with a Red Marker Ball. The Red Marker Ball will be installed by the EDTI Inspector.
- 2.11.3 Where gas easements exist, the service ducts are to be extended past the gas easement and capped. The Red Marker Ball will be installed by the EDTI Inspector.
- 2.11.4 Locations of service ducts are to be staked with yellow stakes to identify their location. The stakes must be a 2" x 4" minimum and 1.5 m in length, 450 mm above final grade.

### 2.12 Cross Sections and Alignments

- 2.12.1 Approved City of Edmonton Design and Construction Standards Volume 2 - Roadway cross sections are to be used in all designs. The detailed Power Plan is to have the alignment of power cable indicated. In some circumstances there may be more than one alignment in the same section of roadway (i.e. because gas may be in an easement in one area but then jogs into the blvd. in another area). The "alternate" alignments are to be included.
- 2.12.2 Cross Sections are to show the alignment of the transformer if the transformer is not centred on the centre of trench.
- 2.12.3 Alignment of cables at corner cuts will be 1.25 m from the corner cut unless otherwise detailed on the power plan.
- 2.12.4 Where any alignments are not obvious or do not parallel a property line, a dimensioned cross section detailing the alignment is required (i.e. where a trench parallels a curb or path rather than paralleling a property line).

### 2.13 Pipeline Crossings and Pipeline Proximity Agreements

- 2.13.1 Pipeline crossing and pipeline proximity agreements are to be secured by the consultant on behalf of EDTI and a copy sent to EDTI Land Servicing. The developer must bare the costs of securing the agreement.
- 2.13.2 Where EDTI Distribution Standards conflict with the pipeline company's requirements, the pipeline company's requirements shall prevail. EDTI must be consulted of any deviation to the EDTI Distribution Standard in advance to construction.
- 2.13.3 Pipeline crossings shall be sized as per EDTI Distribution Standards 6300070037001 and 6300070037002 and must have end bell collars permanently installed at each end of the open duct.
- 2.13.4 Pipeline crossings shall extend at least 1.0 m past either side of the right of way.

### 2.14 Railway Crossings

- 2.14.1 Railway crossing agreements are to be secured by the consultant on behalf of EDTI and a copy sent to EDTI Land Servicing. The developer must bare the costs of securing the agreement.
- 2.14.2 Where EDTI Distribution Standards conflict with the railway company's requirements, the railway company's requirements shall prevail. EDTI must be consulted of any deviation to the EDTI Distribution Standard in advance to construction.

- 2.14.3 For details on railway crossings, steel casing pipe, compaction (exceeds City of Edmonton compaction standards), depths of steel casing pipe, follow the National Transportation Act, General Order No E-11, Regulations Respecting Standards for Wire Crossings and Proximities, the Transportation Canada, TC E-10, Standards Respecting Pipeline Crossings Under Railways and CSA C22.3 No 7.
- 2.14.4 A profile and cross section are to be included with the engineering set of drawings. The size and type of steel casing pipe (i.e. 150 mm threaded galvanized rigid steel conduit with threaded rigid steel couplings welded on the outside or some other suitable method) must be identified on the cross section. Cable cannot be pulled into a steel casing pipe unless it has smooth surface (i.e. EDTI approved galvanized rigid steel threaded pipe and couplings or a pvc sleeve (duct) inside of steel casing pipe and the void filled to keep the sleeve from moving when cable is pulled in).
- 2.14.5 The profile plan must show top of rails, ditches, depths of proposed steel casing pipe at various points (i.e. top of rail, bottom of ditch), length of steel casing pipe and how far from edge of rails the casing pipe will extend. This plan must be signed by a Professional Engineer, P.Lic. (Eng.) or P.Tech.
- 2.14.6 If a cable duct is installed inside of the steel casing pipe it must be sized as per EDTI Distribution Standards 6300070037001 and 6300070037002 and must have end bell collars permanently installed at each end of the open duct. The cable duct must extend at least 1.0 m past the end of the steel casing pipe and the void between the ducts and the steel encasing pipe must be sealed at each end with an EDTI approved sealant (i.e. EDTI approved sealing material to resist movement of the cable duct and assist with reducing thermal resistivity)

## 2.15 Transportation Utility Corridor (T.U.C.) Crossings

- 2.15.1 When EDTI equipment needs to be installed within the TUC, an application for Ministerial Consent to carry out construction and right of entry to the TUC must be obtained. The Consultant will be responsible for preparing the application drawing to City of Edmonton, EDTI and provincial government (e.g., Alberta Transportation) requirements and will submit the stamped drawing in electronic format to EDTI. EDTI will submit the application through EDTI's Land Group to the Province for review/approval. If the Province has additional requirements for the submitted drawing, the Consultant will be responsible for completing the requested revisions and resubmitting the stamped drawing. Once an approved application is received by EDTI, EDTI will forward the approved application to the Consultant. The Ministerial Consent document must be on-site during construction and made available to the EDTI Inspector upon request. The EDTI Inspector must be on-site during construction.
- 2.15.2 The Ministerial Consent document must be on site during construction and made available to the EDTI Land Servicing Inspector upon request.
- 2.15.3 EDTI Land Servicing must be consulted of any deviation to the EDTI Distribution Standard in advance to construction.
- 2.15.4 The crossing must be in duct and shall be sized as per EDTI Distribution Standards 6300070037001 and 6300070037002 and must have end bell collars permanently installed at each end of the open duct.
- 2.15.5 A stamped as-built must be provided as per the Ministerial Consent's document.

## 2.16 Other Crossings or Proximity agreements (EDTI or other utilities)

- 2.16.1 Crossing agreements and proximity agreements are to be secured by the consultant on behalf of EDTI and copies sent to EDTI Land Servicing. The developer must bare the costs of securing any agreements. Note that some utility companies have master agreements in place with EDTI and so a copy of these existing agreements is not necessary.
- 2.16.2 EDTI must be consulted of any deviation to the EDTI Distribution Standard in advance to construction.
- 2.16.3 The crossing must be in duct and shall be sized as per EDTI Distribution Standards 6300070037001 and 6300070037002 and must have end bell collars permanently installed at each end of the open duct.
- 2.16.4 If the purpose of the crossing is a means of extending EDTI power cable from a main power trench on City property across another utility's right of way (the crossing) to EDTI padmounted equipment in an easement, the duct shall be continuous. The EDTI easement will overlap the area of the other utility (i.e. a portion of the easement will be shared by EDTI and gas) or there will be a specific crossing agreement in lieu of an EDTI easement for the crossing (i.e. crossing a railway).
- 2.16.5 Where an easement has been obtained for the benefit of EDTI, no other utility may build facilities within that easement without prior written permission from EDTI (i.e. the contractor cannot use an EDTI easement to conveniently extend a drainage connection or communications duct to private property).



## 2.17 Schematic Requirements

- 2.17.1 The following will be shown on the schematic 1<sup>st</sup> submission:
- 2.17.2 Stage boundaries labelled on the schematic (a dotted line signifying the transition from one stage to the next).
- 2.17.3 Connection points from previous stages (i.e. from “LC” of P16353 or from A1 of S3245).
- 2.17.4 Transformers with the “LA” and “LC” to be shown (note that “LA” of the transformer is located on the left hand side of the transformer and the “LC” on the right (cable connections and schematics are to reference this connection so that cable connects to the corresponding “LA” or “LC” without having lines cross each other on the power plan).
- 2.17.5 Where cable is looped, a loop is to be shown in the schematic and the location of the looped noted.
- 2.17.6 Cubicles are to be shown and size of service ducts shown.
- 2.17.7 Phasing to be shown on 3-phase cubicles (i.e. A1, A2, A3, B1, B2, B3).
- 2.17.8 Proposed temporary looping to be shown with a dotted line and noted as a temporary connection.
- 2.17.9 The following will be shown on the schematic final submission:
- In addition to other subsequent submissions, the final submission will include pad numbers.

## 2.18 Drawing Submission / Approval process

- 2.18.1 The Consultant shall follow the drawing submission/approval/red-line process as defined in Volume 1 – General of the City of Edmonton Design and Construction Standards.

## 2.19 Approved Power Drawing and Schematic

- 2.19.1 In addition to the drawing submission process identified by the City of Edmonton, EDTI will require the Consultant to submit to EDTI:
- A complete PDF version of the engineering drawings signed off on by the City of Edmonton
  - An electronic version of the latest Base Plan and approved Power Plan and Schematic

## 2.20 Construction Completion Certificates (C.C.C.)/Final Acceptance Certificates (F.A.C.):

- 2.20.1 Upon completion of construction, a City of Edmonton, Construction Completion Certificate may be submitted by the Developer as per the process defined in Volume 1 – General of the City of Edmonton’s Design and Construction Standards. If EDTI accepts the work completed, then the certificate will be approved. The CCC will have a maintenance period of one year. Until the FAC is approved, the Developer will be responsible for deficiencies.
- 2.20.2 After completion of the one year maintenance period, a City of Edmonton Final Acceptance Certificate may be submitted by the Developer as per the process defined in Volume 1 – General of the City of Edmonton’s Design and Construction Standards. If there are no outstanding maintenance issues, then EDTI will approve the certificate.

## 2.21 Construction Cost Letter

- 2.21.1 EDTI requires a letter from the developer outlining the cost of the power installation. This letter is used by EDTI for accounting purposes and represents the power facility assets installed by the developer on behalf of EDTI. Contact EDTI Land Servicing for the current required cost breakdown.
- 2.21.2 Applying for Underground Residential Development (URD) lot rebates, Underground Industrial Development (UID) rebates and Feeder Rebates.

## 2.22 Applying for Underground Residential Development (URD) lot rebates, Underground Industrial Development (UID) rebates and Feeder Rebates.

- 2.22.1 The Developer is eligible for rebate once all facilities contained in Schedule B of the City of Edmonton Servicing Agreement are installed. Payment is made after the Developer submits the rebate request and has met the CCC requirements identified in Schedule G of the Servicing Agreement.

- 2.22.2 Lot rebates are straightforward whereas feeder rebates can be more complicated and are reliant on the accuracy of the as-built submitted by the contractor. It is to the Developer's benefit that the contractor provides details of feeder construction methods to enable EDTI to provide an equitable rebate. A quantity take off sheet should be considered as a supplement to the as-built. Work methods should be differentiated on the as-built plan or takeoff sheet, i.e. backhoe vs directional drilling of road crossings; size of drill and number of pipes; shared trench vs power only; number of parties sharing trench; additional cable for temporary looping; additional engineered civil infrastructure.

### 2.23 Damage to facilities

- 2.23.1 The Developer is financially responsible for the repair of 3rd party damage during the one year warranty period as per section 5.7(b) of the Servicing Agreement. Repairs of energized equipment will be coordinated by EDTI Land Servicing.
- 2.23.2 Any damage occurring prior to EDTI energizing the area will be the responsibility of the developer to correct. Retesting of cables and equipment may be required.

OBSOLETE

### 3. TRENCHING, CABLING AND INSTALLATION OF BASES

#### 3.1 GENERAL REQUIREMENTS

- 3.1.1 The following section outlines the installation of ducts, cable, bases transformers, switching cubicles and ground grids. The responsibility to ensure that the installation is completed using EDTI acceptable practices and to EDTI approved Underground Distribution Standards extends to both the Developer and the Contractor. Where EDTI Underground Distribution Standards or EDTI acceptable practices are mentioned, it will be understood to include EDTI Distribution Standard drawings, EDTI approved material, EDTI policy or procedures, or clarification by means of emails, letters or meetings. It is therefore up to the contractor to seek out these EDTI Underground Distribution Standards or EDTI acceptable practices and all amendments thereto.
- 3.1.2 Refer to other sections for clearances, EDTI Distribution Standard drawings, EDTI Construction Drawings and procedures.
- 3.1.3 EDTI expects that the Alberta Electrical Utility Code and CSA C22.3 No. 7 are followed and where EDTI Distribution Standards exceed these minimum standards, EDTI Distribution Standards shall be followed. From time to time, these standards are updated and so it is the contractor's responsibility to use updated standards and practices or to seek out updates from EDTI.
- 3.1.4 All work is to be inspected by and built to the satisfaction of the EDTI Inspector and EDTI Land Servicing.
- 3.1.5 The Consulting Engineer will inform EDTI Land Servicing that the approved engineering drawings (Power Plan and Schematic) are uploaded or emailed to the Land Servicing inbox before the Contractor makes any arrangements with the EDTI Inspector to perform inspections. Approved plans are to be available three Working Days prior to the pre-construction meeting.
- 3.1.6 The contractor must contact the EDTI Inspector at 780-412-4591 three Working Days in advance of requiring an EDTI Inspector on-site.
- 3.1.7 The contractor must contact the EDTI Inspector two Working Days in advance to provide notification of any break in construction and prior to construction restarting.
- 3.1.8 It is the responsibility of the developer/contractor to secure suppliers of EDTI approved transformers, switching cubicles, cable, elbows, bases and any other material required to complete the project. EDTI does not supply material.
- 3.1.9 It is the Developer's responsibility to obtain all approvals for construction and any deviation from construction. It is the Consulting Engineer's responsibility to discuss the proposed deviation with EDTI Land Servicing and supply red-lined drawing(s) as per the process defined in Volume 2 – General of the City of Edmonton's Design and Construction Standards. The EDTI Inspector has the option to stop the construction if the deviation has not been approved by Land Servicing through the red-line process.
- 3.1.10 In this document, where sand is referenced for shading or cover cable, it shall consist of the following:
- All sand shall be provided by the Developer and shall be free of clay, rocks, organic materials, and any deleterious contents.
  - The bedding sand shall be tested using ASTM C136 (Standard Test Method for Sieve Analysis of Fine and Coarse Aggregates). It is the contractors responsibility to ensure that the installed sand meets the following specification.

Test Method	Grading Sieve Sizes (mm)	Percent Passing
ASTM C136	No. 30 (0.6 mm/600 microns/30 Mesh)	100
	No. 40 (0.425mm/425 microns/40 Mesh)	98 - 100
	No. 50 (0.3mm/300 microns/50 Mesh)	55 - 75
	No. 100 (0.15mm/150 microns/100 Mesh)	5 - 40
	No. 200 (0.075mm/75 microns/200 Mesh)	0 - 5
ASTM D7928	Plasticity Index	(Non-Plastic)

- The colour of the bedding sand shall range between the colours shown in Figure 1 below, the inspector will reject any material that does not adhere to the colour spectrum shown in this document:



- 3.1.11 All bends referred to in this document must be rigid PVC bends unless otherwise specified and approved by EDTI Land Servicing. No other types of bends are acceptable.

### 3.2 Safety

- 3.2.1 If a service agreement exists between the Developer and the City of Edmonton and the contractor is hired by the developer, the construction site is not under EDTI's control. It is the responsibility of the developer to ensure that the contractor completes a hazard assessment of the work site and take effective measures to control the hazards identified as per the Alberta Occupational Health and Safety Act, Regulation, and Code. All workers who may be affected by the hazards must be familiar with the necessary health and safety measures or procedures and that safe-work practices are to be followed. These measures or procedures extend to EDTI workers who may be asked to be present on the work site.
- 3.2.2 If a contract exists between the contractor and EDTI, responsibility for safety is outlined in the contract and will include EDTI safety procedures and policies as well as the Alberta Occupational Health and Safety Act, Regulation, and Code. It is the responsibility of the contractor to ensure that a hazard assessment of the work site be completed and take effective measures to control the hazards identified. All workers who may be affected by the hazards must be familiar with the necessary health and safety measures or procedures and that safe-work practices are to be followed. These measures may be included as part of the contract and indicate that the contractor follow EDTI Safe Work Practices.

### 3.3 Grades, Staking, Surveying and As-built

- 3.3.1 All staking and surveying shall be the responsibility of the developer and shall be completed by a registered land surveyor.
- 3.3.2 Where curbs are not installed, final grade must be staked (final grade for the trench) at regular intervals parallel and offset to the power trench alignments so that the stakes are not damaged during the trenching process.
- 3.3.3 Where curbs are not installed, final grade must be staked for padmounted equipment.
- 3.3.4 Where curbs are not installed, final grade must be staked for service entry points.
- 3.3.5 Where the slope of grade exceeds 2% from curb or is significantly different in the area being worked compared to the height of the curbs (i.e. due to berming), final grades must be staked for that area which is not at the same height as adjacent curbs.
- 3.3.6 The contractor shall ensure that the working grades are within +125 mm or – 250 mm of final grade and that the final grade is staked prior to construction. The area must have a consistent grade and have 4.0 m of working surface. Additional working surface area will be required around padmounted equipment. If the site does not meet these limits, the EDTI Land Servicing Inspector may not allow the trenching, cabling or building of bases.
- 3.3.7 All alignments, crossings, bases, service entry points, property lines, future face of curbs (where no curbs exist) are to be marked out with stakes and verified by a walk-through with an EDTI Inspector prior to and during construction. If additional survey staking is required, it is the Developer's responsibility to provide it.
- 3.3.8 Cross-section plans are to be consulted for staking of trenches along roadways.
- 3.3.9 Where EDTI Inspectors have identified additional staking or re-staking for grade, property lines, crossings, service entry points, bases, trench alignments, curbs or for any other reason the contractor is to provide additional staking using the developer's registered land surveyor.
- 3.3.10 Where lot lines are not at 90 degrees to the front property lines, rear property pins are to be staked. The reason for this is to allow for the installation of service coils into the property at 90 degrees to shared property lines.

- 3.3.11 Upon completion of the installation of equipment, a marked up as-built is to be prepared by the contractor in the presence of the EDTI Inspector and each will sign their own as-built for future use. This copy of the as-built must be submitted to the consultant in preparation of a permanent record as-built to be submitted to EDTI Land Servicing by the consultant. It is in the contractor's best interest to complete this part of the process in a timely fashion to ensure energization of the area can be completed. Alignments, crossings, location of equipment and service entry points are to be noted on the drawing with any changes to proposed locations.
- 3.3.12 The staking of trenches at corner cuts will be 1.25 m parallel to corner cuts unless otherwise noted on the power plan.
- 3.3.13 Approved Red-lined drawings for deviation from the approved power plan alignments, crossings or padmounted equipment must be made available to the EDTI Inspector upon request.

### 3.4 Trenching, Ducts, Troughs and Backfilling of Trenches

- 3.4.1 All bends referred to in this document must be rigid PVC (Sch. 40) bends unless otherwise specified and approved by EDTI Land Servicing. No other types of bends are acceptable.
- 3.4.2 Ducts should be 4 inch or 6 inch diameter, 5 inch is no longer acceptable.
- 3.4.3 The minimum width of a typical power trench is:
- 900 mm (36") when Shared Trench includes Gas
  - 600 mm (24") when Shared Trench does not include Gas
  - 600 mm (24") for service trench stub-outs with sand around the service box
  - 300 mm (12") for Power Trench when only primary cable f
- 3.4.4 The maximum depth of a power cable is to be 1.5 m to the bottom of the cable (bottom of trench) from final grade.
- 3.4.5 The minimum cover over a power cable is 1.1 m to the top of cable or power duct from final grade.
- 3.4.6 Per EPCOR's *Guidelines for working in close proximity to electrical equipment* handbook (<https://www.epcor.com/learn/safety/worker-contractor/contractor-handbook/>), Marker Tape should be installed 300 mm above EPCOR cable and ducts, when backfilling.

#### BACKFILL REQUIREMENTS FOR CABLES AND DUCTS

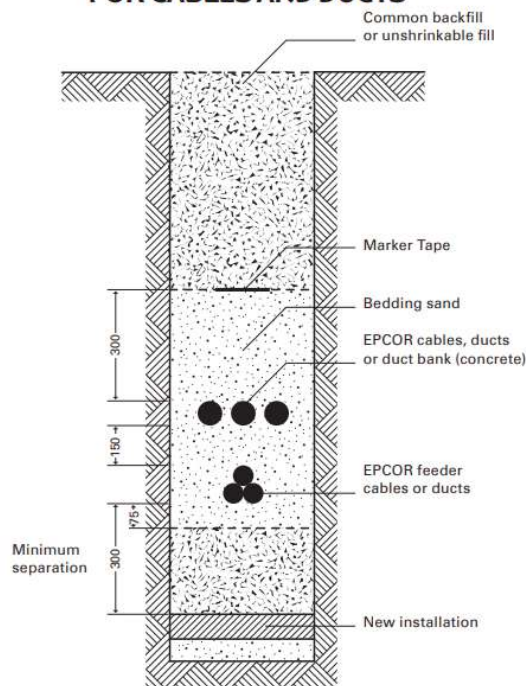

NOTE: all dimensions are stated in millimetres and are minimum requirements

- 3.4.7 The depth of trench must be consistent. If in the opinion of the EDTI Land Servicing Inspector, that the trench depth is not consistent or is too shallow or too deep, corrective measures must be taken which can include sanding (where the trench is too deep) or retrenching if too shallow. If cable has already been laid in the trench, it must be removed, before the trench is repaired and then laid again after receiving permission from the EDTI Land Servicing Inspector.
- 3.4.8 If trenches are left open for more than 72 hours, or if the walls have collapsed, or if other material has entered the trench (i.e. lumps, snow, water), the EDTI Land Servicing Inspector may request that corrective measures be taken which can include cleaning the trench or backfilling, compacting and retrenching.
- 3.4.9 The EDTI Land Servicing Inspector must be contacted and give permission prior to any cabling or backfilling of trenches. If in the opinion of the EDTI Land Servicing Inspector, the trench has been backfilled without the Inspector's approval, corrective measures must be taken which can include exposing the cable, excavating the backfill over the cable, removing the cable, backfilling, re-compaction, retrenching and re-installing the cable.
- 3.4.10 In some cases where multiple runs of primary are in the same alignment, wider trenches or an additional trench or trenches may be required (i.e. 1.0 m separation, centre to centre of trench). See EDTI Distribution Standard drawings in regards to Random and Fixed separation of primary.
- 3.4.11 See other sections for clearances of power facilities to other utilities.
- 3.4.12 Where these clearances cannot be met then a 4 sided trough with concrete or ducts with concrete 1.5 m past either side of the other utility or obstruction must be installed. The trough or ducts are to be installed between the obstruction and private property wherever possible (i.e. between the hydrant and property line). Note that where ducts are installed, primary can only share ducts with other primary and secondary can only share ducts with other secondary and cannot be combined in the same duct as communications.
- 3.4.13 Where there are Communications pedestals with concrete bases to be installed over power trenches, the primary/secondary trenches must be troughed (4 sided troughs) under the base to allow for future maintenance of the cable without disturbance to the concrete base. In some cases a combination of ducts and troughs can be used. Note that where ducts are installed, primary can only share ducts with other primary and secondary can only share ducts with other secondary and cannot be combined in the same duct as communications.
- 3.4.14 Backfill material can be the material excavated from the trench by a mechanical trencher, if in the opinion of the EDTI Land Servicing Inspector, that the material is suitable (i.e. spoil pile from the trencher). Soil having high thermal resistivity containing large amounts of organics, peat, black loam, sod, clay that has hardened, stones, straw, snow or frozen material will not be acceptable. All backfill material will be subject to the approval of the EDTI Land Servicing Inspector. Sand or clean backfill material must be substituted for unsuitable backfill.
- 3.4.15 Where clay is used as the backfill material, the moisture content of the clay cannot exceed the plastic limit, or more than 15%, when being placed in the trench.
- 3.4.16 Backfill shall be placed in uniform lifts not exceeding 300 mm and compacted according to the City of Edmonton Design and Construction Standards Volume 2 – Roadways, which outlines the requirements for compaction. Fillcrete is not allowed to backfill trenches or excavations, over bare cable.
- 3.4.17 The EDTI Inspector must be present prior to excavation of a trench requiring re-compaction. Where re-compaction of a power or shared trench containing energized power cables is required, the contractor shall provide their ground disturbance procedure and notify the EDTI Inspector two Working Days in advance of excavation. Refer to section 3.19.5.
- 3.4.18 All pushes for road crossings or in the boulevards will require interlocking rigid PVC (Schedule 40) ducts to be pulled in before installing cable. Pulling cable into native soil is not acceptable as there is no way of knowing the conditions that the cables are being pulled into. EPCOR can provide specifications of approved interlocking rigid PVC ducts.
- 3.4.19 Where the Developer/Consultant decides to utilize a Shared Trench – With Gas design, the following design requirements apply (refer to Drawing 41 for typical cross-sections)
- The 4-Party Trench (shared trench with gas) typically will be on a utility right-of-way that is 2.7 m wide.
  - The power cables are typically centred 1.28 m inside the property line.
  - The trench/excavation will be 900 mm wide and centred 1.5 m inside the property line.
  - Power, street lighting and communication cables/conduits shall be placed on the "road" side of the trench. Natural gas pipe will be on the "property" side of the trench. The power and communication side of the trench shall be dug in such a way that the trench accepts all the communication conduits on the bottom of the

trench, then sand shading, then the power cables. The gas side of the trench shall be dug at 1.1 m depth. Stakes are to be installed to ensure the power, street lighting and communication cables/conduits are a minimum of 300 mm from the natural gas pipes.

- A minimum 300 mm layer of sand shall be placed over top of the power facilities. A warning tape shall be placed on top of the sand, and native clay backfill can then be placed in the excavation. Compaction requirements for the trench/excavation are to be according to the City of Edmonton Design and Construction Standards Volume 2 – Roadways.
- The bottom of the cable should be at a maximum depth of 1.5 m from final grade. The minimum cover over a power cable is 1.1 m to the top of the cable or power duct from final grade.
- Communication conduit(s), if required, will be installed at the deepest level, with a minimum of 100 mm of sand over top of the conduit(s).
- Power and communication service cables/conduits are to be installed across the utility right-of-way underneath the natural gas distribution line.
- The service box shall be buried outside of the utility right-of-way so that it is a minimum of 800 mm below the rough grade. The service box shall be backfilled with a minimum of 300 mm of sand around the box, and have warning tape.
- All road crossings shall be extended trench line to trench line with bell end collars.
- After all cable is installed, the gas main and tees can be installed.
- Gas tees will be installed closest to property lines.
- Gas tees must be covered with 300 mm of sand.

### 3.5 Road Crossings

- 3.5.1 All power road crossings are to have an end bell collars installed permanently at both ends of the crossing. End bell collars should be installed after the main trench is excavated but prior to pulling in cable so that they are not damaged by a trencher or other equipment. In crossings where it is impossible to install the end bell collars, corrective measures must be taken such as installing a new crossing or installing split collars and leaving the split collars installed (do not remove them).

All power road crossings are to be at 1.3 m to the top of the duct wherever possible. The minimum acceptable depth is 1.1 m to the top of the duct and the maximum allowable depth is 1.5 m to the bottom of the duct from final grade (similar to trench depths). Wherever possible, the preferred crossing depth of 1.3 m to the top of the duct is to be followed. Where crossings have been installed shallower or deeper than the allowable depth, corrective measures must be taken which can include abandoning the crossing and installing a new crossing at the allowable depth.

- 3.5.2 The top of the shallowest duct in a shared crossing is 1.1 m regardless of whether it is power or another utility in the same crossing as power. Therefore, consideration must be given to the number of crossing ducts and the width of a crossing to allow for multiple ducts while maintaining the minimum and maximum depths of crossings.
- 3.5.3 Where cables exit crossings, the area must be covered with a minimum of 300 mm of sand.
- 3.5.4 All cable pulled through crossings must be pulled using acceptable industry practices using equipment designed for that purpose and with lubricant manufactured for use with the cable being pulled. EDTI can provide a list of EDTI acceptable lubricants for this purpose.
- 3.5.5 The contractor must take care while preparing for a cable pull to avoid damage from kinking, rough handling, dragging cable over rough surfaces, driving over cable, walking on cable, or exceeding bending radius of the cable (i.e. bending radius-generally 8 times the cable diameter or manufacturer specs).
- 3.5.6 Up to 3 primary cables can be installed in one duct. The primary cables chosen to share the same duct must originate from the same set of switches (i.e. primary from an A1 switch could only be installed with primary from A2 or A3 and not with primary from B1, B2, B3 or any other switches). It is intended that primary cable be pulled through the duct as one pull where possible. Consideration will be given where cables are of different lengths.
- 3.5.7 In some cases, primary from the same switch may double back on itself (loops) in the same duct.
- 3.5.8 Road crossings near street light bases must be a minimum of 1.5 m from the base to the centre of the closest power duct.
- 3.5.9 Crossings at pad mounted equipment in City Boulevard (not on an easement) cannot be centre of the equipment.

- 3.5.10 Crossings near 1-phase switching cubicles and transformers in the City Boulevard (not on an easement) must be a minimum of 2.5 m from the centre of base.
- 3.5.11 Crossings near 3-phase switching cubicles and transformers in the City Boulevard (not on an easement) must be a minimum of 3.0 m from the centre of base.
- 3.5.12 Where switching cubicles are installed in boulevards or on easements, the crossing ducts are continuous from the fused switch of any switching cubicle to the property line of the lot it is intended to service. The number of bends and length of duct must be considered so that recommended pulling tension of future cable is not exceeded.
- 3.5.13 Crossings shall be sized as per EDTI Distribution Standards 6300070037001 and 6300070037002.
- 3.5.14 Where multiple runs of primary are required, road crossing horizontal clearances from each run of primary may be required (i.e. 1 m separation centre to centre of each crossing). See the power plan for details on alignments of multiple runs of primary.
- 3.5.15 It is understood that the electrical contractor must extend gas crossings after the power cabling has been completed. Where a gas crossing is extended and crosses a power alignment, care must be taken so that it crosses the main power trench with 300 mm vertical separation using sand to separate the two facilities. Where it is impractical to achieve a 300 mm vertical separation using sand, then smooth mechanical separation, such as a four sided trough must be installed.
- 3.5.16 Crossings should always be aligned so that the power duct crosses the road at right angles (90 degrees), wherever possible.
- 3.5.17 Backfill and compaction for the road crossing shall be placed in uniform lifts not exceeding 300 mm and compacted according to the City of Edmonton Design and Construction Standards Volume 2 – Roadways, which outlines the requirements for compaction.

### 3.6 Pipeline Crossings and Pipeline Proximity Agreements

- 3.6.1 Pipeline crossing and pipeline proximity agreements are to be secured by the consultant on behalf of EDTI and a copy sent to EDTI Land Servicing.
- 3.6.2 Pipeline crossing and pipeline proximity agreements must be signed by the pipeline company's representative prior to construction.
- 3.6.3 Signed pipeline crossing agreements and pipeline proximity agreements must be on-site during construction and made available to the EDTI Land Servicing Inspector upon request.
- 3.6.4 It is the contractor's responsibility to ensure that the pipeline company is contacted, is on-site and the work is completed to the pipeline company's satisfaction as well as to EDTI Distribution Standards. Where EDTI Distribution Standards conflict with the pipeline company's requirements, the pipeline company's requirements shall prevail. EDTI must be consulted of any deviation to the EDTI Distribution Standard in advance to construction.
- 3.6.5 Pipeline crossings shall be sized as per EDTI Distribution Standards 6300070037001 and 6300070037002 and must have end bell collars permanently installed at each end of the open duct.
- 3.6.6 Pipeline crossings shall extend at least 5.0 m past either side of the right of way.
- 3.6.7 Where the crossing intersects the pipeline, a minimum of 300 mm separation from the edge of one facility to the edge of the other facility is to be maintained using sand or some other suitable method acceptable to the pipeline company for the separation of the two facilities.
- 3.6.8 The crossing will be either above or below the pipeline depending on depths and the pipeline inspector's requirements.

### 3.7 Railway Crossings

- 3.7.1 Railway crossing agreements are to be secured by the consultant on behalf of EDTI and a copy sent to EDTI Land Servicing.
- 3.7.2 Railway crossing agreements must be signed by the railway company's representative prior to construction.
- 3.7.3 Signed railway crossing agreements must be on site during construction and made available to the EDTI Land Servicing Inspector upon request.
- 3.7.4 It is the contractor's responsibility to ensure that the railway company has been contacted at least 72 hours in



advance, is on-site and the crossing is completed to the railway company's satisfaction as well as to EDTI Distribution Standards. Where EDTI Distribution Standards conflict with the railway company's requirements, the railway company's requirements shall prevail. EDTI must be consulted of any deviation to the EDTI Distribution Standard in advance to construction.

- 3.7.5 For details on railway crossings, steel casing pipe, compaction (exceeds City of Edmonton compaction standards), depths of steel casing pipe, follow the National Transportation Act, General Order No E-11, Regulations Respecting Standards for Wire Crossings and Proximities, the Transportation Canada, TC E-10, Standards Respecting Pipeline Crossings Under Railways and CSA C22.3 No 7.
- 3.7.6 Where non metallic duct is proposed, an engineering study must be completed as per CSA C22.3 No. 7.
- 3.7.7 A profile and cross section are to be included with the engineering set of drawings. The size and type of steel casing pipe (i.e. 150 mm threaded galvanized rigid steel conduit with threaded rigid steel couplings welded on the outside or some other suitable method) must be identified on the cross section. Cable cannot be pulled into a steel casing pipe unless it has smooth surface (i.e. EDTI approved galvanized rigid steel threaded pipe and couplings or a PVC sleeve (duct) inside of steel casing pipe and the void filled to keep the sleeve from moving when cable is pulled in).
- 3.7.8 The profile plan must show top of rails, ditches, depths of proposed steel casing pipe at various points (i.e. top of rail, bottom of ditch), length of steel casing pipe and how far from edge of rails the casing pipe will extend. This plan must be signed by a professional engineer.
- 3.7.9 If a cable duct is installed inside of the steel casing pipe it must be sized as per EDTI Distribution Standards 6300070037001 and 6300070037002 and must have end bell collars permanently installed at each end of the open duct. The cable duct must extend at least 1.0 m past the end of the steel casing pipe and the void between the ducts and the steel encasing pipe must be sealed at each end with an EDTI approved sealant (i.e. EDTI approved sealing material to resist movement of the cable duct and assist with reducing thermal resistivity)

### 3.8 Transportation Utility Corridor (T.U.C.) Crossings

- 3.8.1 When EDTI equipment needs to be installed within the TUC, a Ministerial Consent permit is required to carry out construction and right of entry to the TUC. EDTI will obtain the permit and provide it to the Consultant and Contractor. The Consultant and Contractor will be responsible for following the conditions stated in the documentation, including but not limited to all notification requirements.
- 3.8.2 The Ministerial Consent document must be on site during construction and made available to the EDTI Land Servicing Inspector upon request.
- 3.8.3 It is the contractor's responsibility to ensure that the crossing is completed as per the Ministerial Consent's instructions. EDTI Land Servicing must be consulted of any deviation to the EDTI Distribution Standard in advance to construction.
- 3.8.4 An as-built must be provided as per the Ministerial Consent's document.

### 3.9 Other Crossings or Proximity agreements (EDTI or other utilities)

- 3.9.1 Crossing agreements and proximity agreements are to be secured by the consultant on behalf of EDTI and copies sent to EDTI Land Servicing. Note that some utility companies have master agreements in place with EDTI and that these copies are not necessary.
- 3.9.2 Crossing agreements and proximity agreements must be signed prior to construction.
- 3.9.3 Signed crossing agreements or proximity agreements must be on site during construction and made available to the EDTI Land Servicing Inspector upon request (unless a master agreement is already in place).
- 3.9.4 It is the contractor's responsibility to ensure that the crossing is completed to the satisfaction of the utility company's inspector as well as to EDTI Distribution Standards. EDTI must be consulted of any deviation to the EDTI Distribution Standard in advance to construction.
- 3.9.5 Where the crossing intersects the other utility a minimum vertical separation of 300 mm from edge of one facility to the edge of the other facility is to be maintained using sand or some other suitable method.
- 3.9.6 The crossing will be either above or below the other utility depending on depths and instructions from the other utility.
- 3.9.7 The crossing shall be sized as per EDTI Distribution Standards 6300070037001 and 6300070037002 and must have end bell collars permanently installed at each end of the open duct.

- 3.9.8 If the purpose of the crossing is a means of extending EDTI power cable from a main power trench on City property across another utility's right of way (the crossing) to EDTI padmounted equipment in an easement, the duct shall be continuous. The EDTI easement will overlap the area of the other utility (i.e. a portion of the easement will be shared by EDTI and gas) or there will be a specific crossing agreement in lieu of an EDTI easement for the crossing (i.e. crossing a railway).
- 3.9.9 Where an easement has been obtained for the benefit of EDTI, no other utility may build facilities within that easement without prior written permission from EDTI (i.e. the contractor cannot use an EDTI easement to conveniently extend a drainage connection or communications duct to private property).

### 3.10 Cabling General Requirements

- 3.10.1 Where other facilities such as street lighting, communications or CATV cable or conduit is placed, care must be taken so that the facilities are neatly placed and if necessary, wider trenches used to allow access to the power facilities for future repairs.
- 3.10.2 Facilities in a trench are to be neatly placed. Where the width of a trench allows for utilities to be neatly separated, power facilities are to be pushed to the curb side of the trench wherever possible.
- 3.10.3 Where cable will be placed above ducts, all ducts must be shaded with a minimum of 100 mm of sand or with trenched material if a mechanical trencher was used, if the material is acceptable to the EDTI Land Servicing Inspector. Backhoed material will not be an acceptable material for shading ducts.
- 3.10.4 Where a trench has been backhoed, cables must be shaded with 300 mm of sand. Backhoed material cannot be placed over cable.
- 3.10.5 Backfill material over cable can be the material trenched using a mechanical trencher, if in the opinion of the EDTI Land Servicing Inspector, that the backfill material is suitable. Soil having high thermal resistivity containing large amounts of organics, peat, black loam, sod, clay that has hardened, stones, straw, snow or frozen material will not be acceptable. All backfill material will be subject to the approval of the EDTI Land Servicing Inspector. Sand or clean backfill material must be substituted for unsuitable backfill.
- 3.10.6 There is a requirement additional cable required to be left in bases of pad mounted equipment. Therefore, before cutting the cable, 5.0 m of additional primary and secondary must be laid out in transformers, 6.0 m of additional primary in 1-phase cubicles and 10 m of additional primary for 3-phase cubicles, measured from the top of the pipe bend for switching cubicles and from the top of boards for transformers. This will ensure that there is enough cable to be trimmed by others for terminations prior to energization.
- 3.10.7 Secondary Cable ends must have heat shrink caps installed (see EDTI Distribution Standard 6600070048175.) Use of electrical tape is not acceptable for sealing cables.
- 3.10.8 Primary Cable ends must be wrapped with elastomeric tape (i.e. Greenline) to prevent the migration of moisture in the cable prior to testing. Elastomeric tape must be wrapped in a spiral shape overlapping one half of each previous wrap at a time and then covered with black low voltage vinyl tape. A minimum of 2 layers of half lapped tape is to be applied. Immediately after testing, primary cable ends must have heat shrink caps installed (see EDTI Distribution Standard drawings).
- 3.10.9 Where stages of construction end, it is necessary to protect the primary or secondary from damage or tampering. For other acceptable work practices or updated work practices or procedures, refer to the EDTI Land Servicing Inspector. Temporary Transformer Bases, Boarding and shading or use of Soil Bags are three acceptable methods of securing primary or secondary.
- 3.10.10 The preferred method of protecting capped or coiled cable for future extension is by installing temporary transformer bases (Refer to Section 3.11 for details.)
- 3.10.11 An alternative method of protecting cable for future extension is to coil cable horizontally, and sand with 300 mm of sand covered with a minimum of 2" X 8" pressure treated planking butted together without voids, covered with an additional 300 mm of sand and then backfilled to grade.
- 3.10.12 Capped cables that are boarded and sanded are to be staked with four yellow stakes marking the location and the circumference of the coiled cable. The yellow stakes must be 2" X 4" by a minimum of 1.5 m in length and 450 mm above final grade.

### 3.11 Protecting Cables using Temporary Transformer Bases

- 3.11.1 EDTI's preferred method of protecting cable is by using temporary transformer bases. Primary or secondary cable is to be trained inside the transformer base compartment, exposing only the capped ends above the sand. (Refer to EDTI Underground Distribution Standard 6600070048100 for details.)
- 3.11.2 If the preferred method is not possible, the cable is to be capped, coiled, sand-bedded, boarded and then

buried.

- 3.11.3 Looped primary cable must be buried below the base, sand-bedded and boarded, and enough sand must be installed to bring the base to grade.
- 3.11.4 The ducts for communications will be extended beyond the base (no trough required) and the length to be extended will be up to the EDTI Inspector's discretion.
- 3.11.5 The street lighting cable is to be capped and a 2.0 m coil extended into the temporary transformer base.
- 3.11.6 Temporary base installation heights and orientation are similar to permanent transformer bases and will be up to the EDTI Inspector's discretion. If a temporary base requires relocating in the future, it will be at full cost to the Developer.
- 3.11.7 Temporary bases must be placed on four pressure-treated boards (2" x 10") parallel to the trench. (Refer to EDTI Underground Distribution Standard 6600070048100 for details.)
- 3.11.8 Capped primary is to be brought into the base through the mouse hole(s) through sand bedding. Consideration must be given to the combination, number and type of cable expected to be inserted into the base. Should there be too many cables, then the contractor could resort to a boarding and shading method or a larger base.
- 3.11.9 The minimum requirements for a lid on a temporary transformer base will be ¼" steel drilled for four bolt holes (not plywood).
- 3.11.10 Only EDTI Land Servicing Inspectors or EDTI tradesman may have access to the temporary base once an area is energized (i.e. hot loops).
- 3.11.11 If it is necessary to insert any cables into the base after an area is energized, it will be done so or by direct supervision of an EDTI Land Servicing Inspector or an EDTI Underground tradesperson.
- 3.11.12 The locations of temporary transformer bases are to be marked on the as-built by the contractor.

### 3.12 Protecting Cables Using Boarding and Shading

- 3.12.1 A method of protecting cable is boarding and shading. Cable must be sanded with 300 mm of sand covered with a minimum of 2" X 10" pressure treated planking butted together without voids, covered with an additional 300 mm of sand and then backfilled to grade. See other sections (e.g. 3.13) for alternative methods of securing primary or secondary cable.
- 3.12.2 Capped cables that are boarded and sanded are to be staked with four yellow stakes marking the location and the circumference of the coiled cable. The yellow stakes must be 2" X 4" by a minimum of 1.5 m in length and 450 mm above final grade.

### 3.13 Protecting Cables Using Soil Bags

- 3.13.1 Soil bags refer to woven bags manufactured specifically for soil or sand and used for covering cable. The size of bag is to be larger than what can normally be lifted manually.
- 3.13.2 These bags break down in ultraviolet light and therefore cannot be expected to hold together while removing them from the site if left for a long period of time.
- 3.13.3 The bags can be placed directly on the cable.
- 3.13.4 All cable must be completely covered and cannot be left exposed.

### 3.14 Secondary Services to Lots

- 3.14.1 Secondary residential service cable is a minimum of 2/C #1/0 Al XLPE CN 600 volt direct buried type USEB cable. (Refer to EDTI Underground Distribution Standard 6300070082002.)
- 3.14.2 Follow the power plan for size of secondary services for each residential lot. Where the size of cable is larger than the minimum, the size will be indicated on the power plan using the legend or some other method acceptable to EDTI Land Servicing.
- 3.14.3 Each residential service shall require an additional 30 m coil left on private property. The entire length of secondary for a residential service shall be installed without a splice and cable end must have heat shrink caps installed (Refer to EDTI Underground Distribution Standard 6600070048175.). The use of electrical tape is not acceptable for sealing cables. Future secondary service cable(s) and streetlight wire(s) should be capped, and a 2.0 m coil extended into a temporary transformer base at the edge of the development or

stage. The stubbed-out cables are to be labelled with white tape and a black permanent ink pen with lot and block numbers when available. If lot and block numbers are not available, cables shall be labelled A-A, B-B, etc. The stubbed-out service cable(s) will be spliced by EDTI or an EDTI-approved vendor when the future stage proceeds.

- 3.14.4 Service coils are to be installed in service boxes (see EDTI Distribution Standard 6600070248001 for box construction) past the gas easement if one exists (see other instructions for side lots).
- 3.14.5 Where side lots require servicing along the longer property line and there is no gas easement, service boxes (power service coils) are to be left straddling the property line to allow for excavation of basements without damaging the power service coils.
- 3.14.6 Where side lots require servicing along the longer property line and there is a gas easement, service boxes (power service coils) are to be "A" services (1.5 m) from the rear property line or serviced from the front property line.
- 3.14.7 The service entry points will be 1.5 m ("A" service), 3.0 m ("B" service) or 4.5 m, ("C" service), or 1.0 m ("D" service) from the lot line and must be installed parallel to the lot lines. Service entry points which are not designated as "A", "B", "C", or "D" will be dimensioned on the power plan. Note the importance of front and rear lot pins staked to allow the installer to parallel the property line.
- 3.14.8 Secondary left in transformers must have the lot numbers clearly marked using permanent black ink on white phasing tape or cable marking stickers or some other permanent method and must be marked on both sides of the cable. If two cables in a transformer have the same lot number then the block number will need to be identified in addition to lot numbers. In cases where lot numbers are not available or service cables are stubbed out for future development, cables shall be labelled A-A, B-B, etc. (Refer to EDTI Underground Distribution Standards 6600071527015 for 15 kV and 6600072527015 for 25 kV.)
- 3.14.9 5.0 m of additional secondary is required in transformers, measured from the centre of where the base will be installed. This will ensure that there is enough cable to be trimmed by others for terminations prior to energization.

### 3.15 Transformers

- 3.15.1 The preferred excavation for bases is a stepped excavation so that the native backfill is not disturbed under the ground grid area. This will help prevent the bending of rods and deformation of the ground grid during the backfilling/compaction process – the area where the ground grid and rods are installed, it should not be dug as deep as what will be required for the base excavation. (Refer to EDTI Underground Distribution Standard 6600070027115 for 15 kV and 25 kV.)
- 3.15.2 Where base excavations are not a stepped excavation, special care must be taken to ensure that the area around the base and the ground rods are backfilled with a maximum of 300 mm lifts of sand or backfill and compacted without damage to the ground rods, ground grid or #4/0 copper ground conductors (tails).
- 3.15.3 The bottom of the excavation where the base will be installed requires 300 mm of compacted road crush (20 mm crushed gravel).
- 3.15.4 A minimum of four 2" X 10 " pressure treated lumber must be installed under bases to assist with the levelling of the base before placing the base and to increase the distribution of the weight of the base.
- 3.15.5 The height of the top of concrete base shall be installed at between 150 mm - 200 mm above finished grade.
- 3.15.6 The City Design and Construction Standards Volume 2 – Roadways, outline the requirements for compaction. The contractor must meet these requirements for compacting around or under a base.
- 3.15.7 Where a 4-sided trough is to be located under a base, the trough will need to extend 300 mm beyond the outside of the ground grid. All troughs are a minimum of 2-2"X8" and 2-2"X10" pressure treated lumber (Refer to EDTI Underground Standard Drawing 6600070046005.)
- 3.15.8 Additional primary or secondary left in transformers must be 5.0 m longer than measured from the centre of the transformer (i.e. 5.0 m additional cable for future trimming by the termination contractor).
- 3.15.9 Where the secondary enters the left mouse hole, lay the secondary on the bottom of the base training the secondary in a clockwise rotation (0.75 of a complete turn around the inside wall of the base) and trim at 1.0 m (minimum) above the top of the base. Ensure the secondary tails are towards the right wall of the base.
- 3.15.10 Where the secondary enters the right mouse hole, lay the secondary on the bottom of the base training the secondary in a clockwise rotation (1.25 of a complete turn around the inside wall of the base) and trim at 1.0 m (minimum) above the top of the base. Ensure the secondary tails are towards the right wall of the base.

- 3.15.11 Where the primary enters the right or left mouse hole, lay the primary on the bottom of the base on top of the secondary coils, training the primary in a counter clockwise rotation (at least one turn) and trim at 2.0 m (minimum) above the top of the base plus enough extra to allow the neutral conductor to be connected to the ground bus without splicing.
- 3.15.12 Two #4/0 bare copper grounding conductors (tails) from the ground grid must be brought into the transformer below the concrete base between the pressure treated lumber or through a mouse hole. The Contractor is to provide 5.0 m of additional bare 4/0 Cu for each of the two tails measured from the top of the wooden planks for future termination work. (Refer to EDTI Underground Distribution Standards 6600070027115).

### 3.16 Switching Cubicles

- 3.16.1 Excavation for bases should be a stepped excavation so that the native backfill is not disturbed under the ground grid area. This will help prevent the bending of rods and deformation of the ground grid during the backfilling/compaction process where the ground grid and rods are installed, it should not be dug as deep as what will be required for the base excavation. (Refer to EDTI Underground Distribution Standards 6600071523114, 6500071523132, 6600072523114 and 6500072523132.)
- 3.16.2 Where base excavations are not a stepped excavation, special care must be taken to ensure that the area around the base and the ground compacted without damage to the ground rods, ground grid or #4/0 copper ground conductors (tails).
- 3.16.3 A minimum of 2" X 10" pressure treated lumber must be installed under bases to assist with the levelling of the base before placing the base and to allow for some spreading of the weight of the base.
- 3.16.4 The height of the top of concrete base shall be installed at between 250 mm and 300 mm above final grade at 3%–5% slope. It is the responsibility of the Developer to ensure that the final grade established during construction is not tampered with after the installation is complete. (Refer to EDTI Underground Distribution Standards 6600071523114, 6500071523132, 6600072523114 and 6500072523132.)
- 3.16.5 The City of Edmonton Design and Construction Standards Volume 2 – Roadways, outlines the requirements for compaction. The contractor must meet these requirements for compacting around or under a base.
- 3.16.6 Where a 4 sided trough is to be located under a base, the trough will need to extend 300 mm beyond the outside of the ground grid. All troughs are a minimum of 2-2"X8" and 2-2"X10" pressure treated lumber. (Refer to EDTI Underground Standard Drawing 6600070046005.)
- 3.16.7 All bends entering the base requires permanent end bell collars on the end of the bends inside of the switching cubicle (do not cut these off or remove them).
- 3.16.8 All spare bends are to be covered (taped or covered by some other suitable method) to prevent material falling into the bends.
- 3.16.9 There must be a bend installed for every compartment of a switching cubicle (i.e. 1 bend for "A", 1 bend for "B", etc.)
- 3.16.10 Each bend which is not capped specifically for a customer's service stub must have an end bell collar permanently installed on the open end outside of the switching cubicle (i.e. both ends of the bend must have end bell collars).
- 3.16.11 The ducts from each fused compartment to the property line that it is intended to service will be continuous without breaks and capped at the property line.
- 3.16.12 Service ducts from cubicles on shared property lines will be parallel to lot lines, typically at 1.5 m service entry points. (Refer to EDTI Underground Distribution Standards 6600070023114 & 6500070023132.)
- 3.16.13 Where gas easements exist, the service ducts are to be extended past the gas easement and capped.
- 3.16.14 Service ducts are to be staked to identify their location with a yellow stake. That stake must be a 2 X 4" minimum of 1.5 m in length, 450 mm above final grade. Service ducts from cubicles on shared property lines will be parallel to lot lines, typically at 1.5 m service entry points. (Refer to EDTI Underground Distribution Standards 6600070023114 & 6500070023132.)
- 3.16.15 Ducts from cubicles in an easement must be continuous from the switching cubicle to the main power trench and have end bell collars installed at each end.

### 3.17 Grounding and Bonding

- 3.17.1 Ground grids are required around all padmounted equipment and consist of four copper clad ground rods interconnected by #4/0 bare copper grounding conductor and an additional 2 X #4/0 bare copper grounding

conductor tails connected to the ground bus of the equipment. The Contractor is to provide an additional 5.0 m of 4/0 bare copper wire for each of the two tails for transformers, single phase switching cubicles and three phase switching cubicles measured from the top of the wooden planks for transformers and from the top of the pipe bends for switching cubicles for termination work. Ground grids to be installed at 300mm to 450mm depth.

- 3.17.2 All electrical connections (for the ground grid) are to be cleaned before making the connection (i.e. free of mud, grease, oil).
- 3.17.3 Where non EDTI equipment is placed within 3.0 m from the edge of EDTI grounding grids, refer to EDTI Underground Distribution Standard 6600070060001, 6000070060001 & 6500070060001. The non EDTI equipment cannot be installed within 1.0 m of the EDTI ground grid.
- 3.17.4 Where non EDTI systems are to be bonded to the EDTI system every 300 m, see the power plan for details of where the connection is to be made and how the non EDTI systems are to be bonded.
- 3.17.5 All mechanical connections need to be torqued per manufacturer's specifications.

### 3.18 Exposing Existing Power Facilities

- 3.18.1 It is understood that some work may be required over energized primary or secondary. This may involve crossing or over trenching of energized primary and secondary. Mechanical excavation is allowed up to 1.0 m from the energized facilities. Therefore, the facilities must be located first using hydro excavating or hand digging methods prior to determining where the mechanical excavation limits end.
- 3.18.2 The contractor shall expose the power cables to sight, complying with AEUC, OHSA of Alberta and EDTI Operating Procedure EX04..
- 3.18.3 The EDTI Inspector must be contacted 48 hours prior to this work. EDTI Inspectors are not expected to advise contractors on the location of Power facilities.
- 3.18.4 Alberta One-Call must be contacted and a current and valid Alberta One-Call ticket c/w locate document must be on-site.
- 3.18.5 All existing power facilities are to be assumed energized. Therefore, follow hydro excavating procedures over energized primary or secondary.

### 3.19 Hydro Excavating Procedure (Hydrovac) over Primary or Secondary

- 3.19.1 For the safety of personnel and assets, the hydro excavating operator must be familiar with and follow the latest AEUC, OHSA of Alberta and EDTI Operating Procedure. A copy of the contractor's ground disturbance procedure must be made available to the EDTI Inspector or Powerline Technician prior to commencement of work and kept on site. Contact any EDTI Land Servicing representative for the latest version of EDTI Operating Procedure EX04.
- 3.19.2 EDTI will allow a contractor to over trench up to 5.0 m of energized facilities by hand or hydro excavating after seeking permission from the EDTI Inspector. The Contractor must follow Alberta One-Call procedures before commencing work.
- 3.19.3 All exposed energized cable cannot be left unattended. If the excavation is narrow or small, the primary must be covered with soil bags or some other suitable temporary method of securing the primary cable. Contact the EDTI Underground Trades Foreman for more details.
- 3.19.4 Under no circumstances can energized primary be moved or handled in anyway by the Contractor. Only an EDTI Certified Powerline Technician is qualified to handle or move energized primary. The Contractor will be charged the full cost for EDTI tradespersons to be on-site. Arrangements must be made in advance with any EDTI Inspector or Powerline Technician.
- 3.19.5 Where re-compaction of a power or shared trench containing energized power cables is required, the contractor shall provide their ground disturbance procedure and notify the EDTI Inspector two Working Days in advance of excavation. The contractor shall expose the power cables to sight, complying with AEUC, OHSA of Alberta and EDTI Operating Procedure.

At the discretion of the EDTI Inspector, additional spotting holes may be required where cable depth and alignment is a concern. The use of a surveyed profile as-built drawing containing ground and cable elevations is recommended during the initial installation and may reduce the amount of spotting required. The following is a list of locations where exposing energized cables to sight is recommended:

- Road and utility crossings

- Change in direction of trench alignment
- $\leq 30\text{m}$  increments for straight spans of trench provided that offset stakes with cable depths have been set at 10m increments

Contractors will not be allowed to use a toothed bucket when exposing energized cables.

### 3.20 Energized Primary

- 3.20.1 Where energized primary is left uncovered, site security personnel must be retained to ensure public safety. Energized primary cannot be left open and unattended.
- 3.20.2 Where it is impractical to have site security for long periods of time then the boarding and shading, temporary transformer base or soil bag method must be utilized to secure energized primary.

### 3.21 Primary Cable Splices

- 3.21.1 When primary cables within the development require splicing due to cable reel ends, damage or crossings, EDTI will be responsible for completing the splices as per EDTI Underground Distribution Standard 6300070048009 (Primary Cable) as follows:
- Splices are to be completed by EPCOR's Certified Journeyman Powerline Technician or Power System Electrician.
  - Splices are to have a Red Marker Ball installed by the Contractor as per EDTI Underground Distribution Standard 6300070017001.
  - All primary voltage splice locations shall be shown on the as-built plan.
  - All primary voltage splices shall have an EDTI Splice Recording Sheet completed and returned to EDTI Land Servicing as part of the as-built package for the development.
  - All splicing on primary and secondary cables will be completed by EDTI.

### 3.22 Splice Pits

- 3.22.1 The Contractor building the stage to be energized will be responsible for providing the splice pits required by EDTI to energize the stage. Splice pit sizes are to be as per EDTI Underground Distribution Standard 6600070048005. Upon completion of the EDTI work, the Contractor will be required to backfill the excavation. Note that in some cases these splice pits may be in stages a considerable distance away from the stage to be energized. All landscaping restoration and sidewalk repairs will be at the expense of the Developer/Contractor. The Contractor must contact EDTI to schedule primary splicing, sanding and backfilling of splice pits.
- 3.22.2 Where water has entered the splice pit, the contractor may be asked to clean out prior to the arrival of EDTI crews.
- 3.22.3 Where splice pits have been excavated over energized primary, cable cannot be left unattended. Therefore the cable must be covered in an acceptable method. The covering will be removed by the contractor in coordination with the EDTI Underground Trades Foreman.
- 3.22.4 Once splicing is completed by the EDTI Underground Tradesman, the contractor must immediately cover the splices with 300 mm sand at least 1.0 m beyond the area where the splices are located. EDTI will place a Marker Ball. The Contractor will then complete backfilling and compaction to the City of Edmonton Design and Construction Standards Volume 2 - Roadways.
- 3.22.5 All splices must be as-built by the contractor.

### 3.23 Removing Temporary Transformer Bases

- 3.23.1 Where temporary transformer bases have been used to cover capped or coils of primary or secondary in previous stages of development, care must be taken when removing these facilities. The Contractor building the stage to be energized will be responsible for removing all temporary transformer bases required by EDTI to energize the stage. Upon completion of the EDTI work, the Contractor will be required to backfill the excavation. Note that in some cases these temporary transformer bases may be in stages a considerable distance away from the stage to be energized. All landscaping restoration and sidewalk repairs will be at the expense of the Developer/Contractor.
- 3.23.2 Mechanical excavation is allowed up to 1.0 m from these temporary bases or from the cable entering the temporary base. Therefore, when working within 1.0 m of the facilities the area must be hydro excavated or hand dug.

- 3.23.3 Alberta One-Call must be contacted to advise contractors on the location of existing power facilities and the completed Alberta One-Call document must be on-site prior to construction.
- 3.23.4 All work proposed near existing power facilities are to be treated as though the existing power facilities are energized. Therefore, follow the hydro excavating procedures.

### 3.24 Installation of DA and AMI Equipment

- 3.24.1 When DA antennas and/or AMI repeater/antenna power services are indicated on the approved power distribution plan, the Contractor will be responsible for installing them as follows:
- DA steel poles – the precast concrete base, the steel street lighting pole and PVC conduit / flex conduit
  - DA fibreglass pole – a 50 mm conduit to the proposed location of the pole. The pole is to be installed by EDTI)
  - AMI steel pole – the precast concrete base, the steel street lighting pole and PVC conduit / flex conduit or power cables to pole with a tail inserted into the steel pole
  - AMI fibreglass pole – a 50 mm conduit to the proposed location of the pole. The pole is to be installed by EDTI

All installations as per EDTI Underground Distribution Standard 6600070007001 and 6600070107001.

### 3.25 Installation of Primary and Secondary Laterals

- 3.25.1 When primary and/or secondary lateral pipes and cables are indicated on drawings, cap cable 1.0m from pole.

### 3.26 Cable Installation in Long Duct Segments or Manholes / Concrete-Encased Ducts

- 3.26.1 When the approved power distribution plan indicates that cable is to be installed in a long length of direct-buried rigid duct (greater than 100 m), or within a manhole or concrete-encased duct configuration, the Contractor will need to follow an EDTI Inspector's instructions for the installation. The installation may include the use of suitable equipment capable of measuring the tensions while the cable is being pulled. Contact EDTI Land Servicing for detailed installation.

OBSOLETE



## 4. TERMINATIONS / TERMINATION INSPECTIONS / CABLE, EQUIPMENT AND GROUND GRID TEST REPORTS

### 4.1 Safety

- 4.1.1 If a service agreement exists between the Developer and the City of Edmonton and the contractor is hired by the developer, the construction site is not under EDTI's control. It is the responsibility of the developer to ensure that the contractor completes a hazard assessment of the work site and take effective measures to control the hazards identified as per the Alberta Occupational Health and Safety Act, Regulation, and Code. All workers who may be affected by the hazards must be familiar with the necessary health and safety measures or procedures and that safe-work practices are to be followed. These measures or procedures extend to EDTI workers who may be asked to be present on the work site.
- 4.1.2 1.2.2 If a contract exists between the contractor and EDTI, responsibility for safety is outlined in the contract and will include EDTI safety procedures and policies as well as the Alberta Occupational Health and Safety Act, Regulation, and Code. It is the responsibility of the contractor to ensure that a hazard assessment of the work site be completed and take effective measures to control the hazards identified. All workers who may be affected by the hazards must be familiar with the necessary health and safety measures or procedures and that safe-work practices are to be followed. These measures may be included as part of the contract and indicate that the contractor follow EDTI Safe Work Practices.

### 4.2 Prior to Terminations or Testing of Pad mounted Equipment

- 4.2.1 Contact the EDTI Safety Codes Department at [safetycodes@epcor.com](mailto:safetycodes@epcor.com), 48 hours in advance, with site contact person and drawing of specific location, to make arrangements for inspection of the terminations on power equipment (i.e. elbow terminations in cubicles and transformers and secondary terminations). In most cases, an EDTI Underground Tradesperson will be assigned to witness the terminations while in progress.
- 4.2.2 It is the responsibility of the developer/contractor to secure EDTI-approved vendors, approved transformers, switching cubicles, cable, elbows, bases and any other material required to complete the project.
- 4.2.3 All electrical connections must be completed by a Certified Journeyman Powerline Technician or Power Systems Electrician using EDTI-approved materials. A worker recognized in the province of Alberta as an apprentice Powerline Technician or Power System Electrician and working under the onsite direct supervision of a Certified Journeyman recognized in the province of Alberta as a Powerline Technician or Power System Electrician may also complete electrical connections. Qualifications and certification produced by the above referenced trades people must be recognized in the Province of Alberta as qualified or certified to work in the Province of Alberta and be experienced in the field of high voltage electrical terminations.
- 4.2.4 At any time, EDTI has the right to suspend or cancel any person or company's privilege to complete terminations on future EDTI assets.

### 4.3 General Requirements for Pad mounted Equipment and Primary Terminations

- 4.3.1 It is the responsibility of the developer/contractor to secure EDTI approved transformers, switching cubicles, cable, elbows, bases and any other material required to complete the project.
- 4.3.2 All electrical connections must be completed by a certified journeyman electrician, certified power lineman, certified power systems electrician or apprentice working under the direct supervision of the certified journeyman electrician, certified power lineman or certified power systems electrician using EDTI approved elbows, EDTI approved termination kits and EDTI approved hardware. Qualifications and certification produced by the above referenced trades people must be recognized in the Province of Alberta as qualified or certified to work in the Province of Alberta and be experienced in the field of high voltage electrical terminations.
- 4.3.3 The name of the tradesperson who will be completing the terminations, certification, qualifications and high voltage electrical termination experience must be on file with EDTI. Therefore, upon request, this information must be forwarded to EDTI Land Servicing or to the EDTI Underground Trades Foreman.
- 4.3.4 The Contractor is responsible for ensuring that all primary cables in a 3-phase switching cubicle have only EDTI-approved fault indicators and fibre optics installed.
- 4.3.5 The "B" elbow of 1-phase switching cubicles requires an EDTI approved Fault Indicator and fibre optic.
- 4.3.6 The "LC" elbow of transformers requires an EDTI approved Fault Indicator.

- 4.3.7 All fibre optic connections in cubicles are to be made to fault indicators on the primary cable and where no primary cable exists, the fibre optic cable is to be neatly coiled. Fibre optic is to be tied to the cable using cable ties and when the fibre optic reaches a point below the bottom of the top lip of the cubicle base, the fibre optic is to be trained towards the wire protector on the switching cubicle. The reason for this is to keep the fibre optic away from the area where the fuse doors are to be swung open.
- 4.3.8 EDTI approved permanent cable identification tags must be installed. The location of this tag is above the fault indicator and if there is no fault indicator required then above the neutral and secured with a cable tie (do not bundle the bleed wire with the cable tie). If the elbow required does not allow for the identification tag to be installed above the fault indicator then the tag must be installed as close as practicable to the fault indicator. See note 4.3.10.
- 4.3.9 Where there are 25 kV connections and vented bushings, blue tags (skate tags) are to be installed. These blue tags are to be attached to the EDTI approved permanent cable identification tag using the same cable tie (do not bundle the bleed wire with the cable tie). See note 4.3.10.
- 4.3.10 Elbow tags should indicate Current Asset (left side) and Connected to Asset (right side). Examples:



- 4.3.11 An EDTI approved Insulated Cap with a Ground Lead must be installed onto each 200 amp bushing with no primary termination and onto a reducing tap plug on elbows larger than 200 amps (both 15kV and 25 kV). The factory lead is to be terminated to the ground bus using EDTI approved hardware (i.e. amp lug sized for the ground lead and size of ground bus bolt c/w EDTI conical washer and EDTI approved flat washer). The excess ground lead is wrapped around the cap by turning the cap until the slack is taken up.
- 4.3.12 All Insulated Caps with Ground leads installed on the window or reducing tap plug of the 400 amp or 600 amp terminations are 25 kV and are identical regardless of the voltage of the cubicle. The window or reducing tap plug is lubricated with a light film of silicone grease and the insulated cap pushed on to the plug. Depending on the supplier, the Insulated Cap with Ground Lead may come as part of the termination kit. The factory lead is to be terminated to the ground bus using EDTI approved hardware (i.e. amp lug sized for the ground lead and size of ground bus bolt c/w EDTI conical washer and EDTI approved flat washer).
- 4.3.13 All Insulated Caps with Ground leads installed onto each 200 amp bushing are rated specifically for 15 kV or 25 kV depending on the voltage class of the cubicle. The bushing is lubricated with a light film of silicone grease and the insulated cap is pushed on. The factory lead is to be terminated to the ground bus using EDTI approved hardware (i.e. amp lug sized for the ground lead and size of ground bus bolt c/w EDTI conical washer and EDTI approved flat washer).
- 4.3.14 An Insulated Cap with Ground lead is required on all transformer bushings where there is no primary cable (i.e. on the last transformer in a subdivision intended to connect to a future subdivision with an empty duct...no primary). This cap is rated for the application, either 15 kV or 25 kV. The bushing is lubricated with a light film of silicone grease and the insulated cap is pushed on. The factory lead is to be terminated to the ground bus using EDTI approved hardware (i.e. amp lug sized for the ground lead and size of ground bus bolt c/w EDTI conical washer and EDTI approved flat washer).
- 4.3.15 All Dead break Insulated Caps with Test Points are installed directly to the 400 amp (25 kV) or 600 amp (15 kV) bushing (hand tightened) where there is no primary cable termination required. A minimum #14 AWG copper lead is to be installed on the Dead break Insulated Cap and terminated to the ground bus using EDTI approved hardware (i.e. amp lug sized for the ground lead and size of ground bus bolt c/w EDTI conical

washer and EDTI approved flat washer).

- 4.3.16 On the installation of a 200 amp elbow, there is no provision for a separate Insulated Cap as the elbow itself performs this function. Therefore, where primary cable is terminated using 200 amp elbows, this is the only instance where the insulated cap is not required.
- 4.3.17 All neutral conductors of primary and secondary cable are to be connected to the ground bus using EDTI approved hardware following EDTI Underground Distribution Standards.
- 4.3.18 The equipment ground of pad mounted equipment must be connected as per EDTI Underground Distribution Standards using four copper clad ground rods interconnected using #4/0 copper grounding conductor and two #4/0 bare copper grounding conductor tails terminated to the ground bus of the equipment with EDTI approved hardware.
- 4.3.19 All electrical connections to the ground bus should be cleaned using steel wool or some other approved method to allow for a better electrical connection.

#### 4.4 Shaping, Termination and Identifying Cables in Transformers

- 4.4.1 Any reference to shaping in this section is while standing facing the front of the transformer.
- 4.4.2 Where the #4/0 copper ground conductors (tails) enters the transformer base, one full coil around the base of both tails is required for termination to the ground bus to separate bolts but in close proximity to each other. The reason that they are in close proximity is to allow for a clip-on ground resistance test on both tails at the same time.
- 4.4.3 Where the secondary enters the left mouse hole, lay the secondary on the bottom of the base training the secondary in a clockwise rotation (0.75 of a complete turn around the inside wall of the base) and trim at 1.0 m (minimum) above the top of the base. Ensure the secondary tails are towards the right wall of the base.
- 4.4.4 Where the secondary enters the right mouse hole, lay the secondary on the bottom of the base training the secondary in a clockwise rotation (1.25 of a complete turn around the inside wall of the base) and trim at 1.0 m (minimum) above the top of the base. Ensure the secondary tails are towards the right wall of the base.
- 4.4.5 Where the primary enters the right or left mouse hole, lay the primary on the bottom of the base on top of the secondary coils, training the primary in a counter clockwise rotation (at least one turn) and trim at 2.0 m (minimum) above the top of the base plus enough extra to allow the neutral conductor to be connected to the ground bus without splicing.
- 4.4.6 Primary cable has limits on its bending radius depending on the size, type of cable and manufacture's specs. In general, EDTI approved primary cable cannot be shaped or stressed (by bending it) into a radius less than 8 times the diameter of the cable.
- 4.4.7 Primary cable loops shall be trained on top of secondary cable loops to allow adequate movement for switching operations.
- 4.4.8 EDTI approved Fault Indicators are to be installed on the "LC" primary cable. The location of the fault indicator is to be located above the neutral. The cable identification tag is to be located above the Fault Indicator.
- 4.4.9 All secondary neutrals are to be terminated with the correct sized lug (see EDTI transformer standard for correct lug sizes), shaped neatly and with EDTI approved hardware.
- 4.4.10 After secondary cable neutrals have been shaped and secured, the jacket that has been stripped back from the cable must line up with the bottom of the top lip of the base.
- 4.4.11 After trimming the secondary, the lot and block number must be identified on the secondary cable attached to the X1 (lower) secondary terminal block using permanent black ink on an opaque plastic tube slipped over the insulation of the secondary.
- 4.4.12 The secondary cables are to be installed in the terminal block and have shrink caps installed (note that the insulation is not to be stripped off) and the set screw on the secondary terminal block is to be loosely secured (so that the secondary/cable tie will not fall through the secondary terminal block). Larger cables are to be secured to the secondary terminal block using cable ties (note that the insulation is not to be stripped off) and a short length of shrink tubing is to be installed to cover the end of the cable. See the transformer EDTI Underground Distribution Standards 6600071527015 and 6600072527015 for details.
- 4.4.13 There must be a ground strap bonding the XO terminal and the tank of the transformer to the ground bus. Therefore the contractor must ensure that this connection exists, is in good condition and is secure.
- 4.4.14 The tap setting of the transformers must be set at 100%.

- 4.4.15 All lifting bolts from transformers must be removed.
- 4.4.16 Four approved tie down plates are to be supplied and installed to secure all transformers to the precast base.

#### 4.5 Shaping and Terminations in 3-Phase Switching Cubicles

- 4.5.1 One full coil of the #4/0 copper ground conductors (tails) are shaped between the "A2" and "A3" bushings of 200 amp, 3-phase cubicles to approximately 150 mm above the height of the ground bails. The tails are shaped at 90 degrees and continue towards the ground bails and will be terminated to separate connectors. One connector will be located on the right side of the "A2" ground bail (stirrup). The other connector will be on the left side of the "A3" ground bail. Note that both connectors must be mounted on the vertical portion of the ground bails so that they do not interfere with the connection of working grounds. The tails will not be trained through the cable guides so that they will not interfere with switching operations of the primary. The connector must be an EDTI approved connector sized for the 5/8" ground bails and the #4/0 copper ground conductors similar to the connectors used in the buried portion of the ground grid. The tails will be shaped and secured together with cable ties to allow easy access for a ground grid resistance check on both tails at the same time.
- 4.5.2 One full coil of the #4/0 copper ground conductors (tails) are shaped between the "A2" and "A3" bushings of 400 or 600 amp, 3-phase cubicles to approximately 150 mm above the height of the ground bus. The tails are shaped at 90 degrees and continue towards the ground bus and will be terminated using bolts and EDTI approved lugs (one bolt for each connection). Both tails are trained together using cable ties so that resistance checks can easily be done on both tails at the same time.
- 4.5.3 From the "A" duct, loop primary in a clockwise direction (one complete loop) and trim at 2.0 m (minimum) above the precast base top plus enough extra to allow the neutral conductor to be connected to the ground bus (400 amp/600 amp) or ground plate (200 amps) without splicing.
- 4.5.4 From the "B" duct, loop primary in a counter clockwise direction (one complete loop) and trim at 2.0 m above the precast base top plus enough extra to allow the neutral conductor to be connected to the ground bus (400 amp/600 amp) or ground plate (200 amps) without splicing.
- 4.5.5 If there is cable in the "C" duct, loop primary in a clockwise direction (one complete loop) and trim at 2.0 m (minimum) above the precast base top plus enough extra to allow the neutral conductor to be connected to the ground bus (400 amp/600 amp) or ground plate (200 amps) without splicing.
- 4.5.6 If there is cable in the "D" duct, loop primary in a counter clockwise direction (one complete loop) and trim at 2.0 m above the precast base top plus enough extra to allow the neutral conductor to be connected to the ground bus (400 amp/600 amp) or ground plate (200 amps) without splicing.
- 4.5.7 Cables are to be shaped to ensure that they do not cover up other ducts.
- 4.5.8 All bends entering the base require permanent end bell collars on the end of the bends inside of the switching cubicle (do not cut these off or remove them).
- 4.5.9 All spare bends are to be covered (end bells taped or covered by some other suitable method) to prevent material falling into the bends.
- 4.5.10 Primary cable has limits on its bending radius depending on the size, type of cable and manufacturer's specs. In general, EDTI approved primary cable cannot be shaped or stressed (by bending it) into a radius less than 8 times the diameter of the cable.
- 4.5.11 Fuse holders are to be installed in the fusing compartments and fuse doors in the closed position.
- 4.5.12 All lifting eyes on switching cubicles are to be turned down.
- 4.5.13 Four EDTI approved tie down plates are to be supplied and installed to secure all switching cubicles to the precast base.
- 4.5.14 Where primary cable exceeds 500 MCM, follow EDTI Underground Distribution Standard 6300070047002 for shaping and cable support.
- 4.5.15 Fibre optic indicators on three phase cubicles must face the nearest road (where the "B" compartment would be on the left hand side of the cubicle while facing the cubicle from the road).

#### 4.6 Shaping and Terminations in 1-Phase Switching Cubicles

- 4.6.1 One full coil of the #4/0 copper ground conductors (tails) are shaped between the "A" and "B" bushings of 1-phase cubicles to approximately 150 mm above the height of the ground bails. The tails are shaped at 90 degrees and continue towards the ground bails and will be terminated to separate connectors. One connector will be located on the right side of the "A" ground bail (stirrup). The other connector will be on the left side of

the "B" ground bail. Note that both connectors must be mounted on the vertical portion of the ground bails so that they do not interfere with the connection of working grounds. The tails will not be trained through the cable guides so that they will not interfere with switching operations of the primary. The connector must be an EDTI approved connector sized for the 5/8" ground bails and the tails similar to the connectors used in the buried portion of the ground grid. The tails will be shaped and secured together with cable ties to allow easy access for a ground grid resistance check on both tails at the same time.

- 4.6.2 From the "A" and "B", loop primary (one complete loop) in counter clockwise direction and trim at 2.0 m (minimum) above the base plus enough extra to allow the neutral conductor to be connected to the ground plate without splicing.
- 4.6.3 If there is a "C" and "D" primary then loop primary (one complete loop) in clockwise direction and trim at 2.0 m (minimum) above the base plus enough extra to allow the neutral conductor to be connected to the ground plate without splicing.
- 4.6.4 All bends entering the base requires permanent end bell collars on the end of the bends inside of the switching cubicle (do not cut these off or remove them).
- 4.6.5 All spare bends are to be covered (end bells taped or covered by some other suitable method) to prevent material falling into the bends.
- 4.6.6 Cables are to be shaped to ensure that they do not cover up other ducts.
- 4.6.7 Primary cable has limits on its bending radius depending on the size, type of cable and manufacture's specs. In general, EDTI approved primary cable cannot be shaped or stressed (by bending it) into a radius less than 8 times the diameter of the cable.
- 4.6.8 All lifting eyes on switching cubicles are to be turned down.
- 4.6.9 Four approved tie down plates are to be supplied and installed to secure all switching cubicles to the precast base.
- 4.6.10 The 1-phase cubicles must be oriented with the road so that the fibre optic indicator is on the right hand side of the cubicle when standing facing the cubicle from the road.

#### 4.7 Ground Grid Testing and Witnessing

- 4.7.1 All ground grid tests are to be witnessed by the EDTI Underground Tradesperson. There will be three levels of testing.
- 4.7.2 All ground grids must be tested to ensure continuity and cannot exceed 6.0 ohms.
- 4.7.3 If the ground grid does not meet EDTI Underground Distribution Standards or exceeds 6.0 ohms then repairs or corrections must be made. These corrections may include:
  - Cleaning connections, replacing damaged rods, copper ground conductors or driving additional rods (adding one to each corner, as needed) to maintain 6.0 ohms or less.
  - Any repairs or replacing of rods, ground conductor or connections are subject to re-inspection, re-testing and witnessing by the EDTI Underground Tradesperson.
- 4.7.4 A "Three Point Test" or a "Clip-on resistance" method of testing is required.
- 4.7.5 Three Point Test:
  - Use instrument with two remote ground rods and the third lead attached to the ground grid.
  - Details of the test procedure available upon request.
  - This test is typically required where there is only one device to be added to EDTI's distribution system.
- 4.7.6 Or a Clip-on Method may be used:
  - Use of approved clip-on apparatus.
  - In transformers and switching cubicles, clip-on both #4/0 copper ground conductors (tails) simultaneously and take the resistance reading.
  - Details of the test procedure are available upon request.
  - This test is typically required where there is more than one device to be added to EDTI's distribution system and is interconnected.

- 4.7.7 Ground grid test reports must include the following data:
- Subdivision Name and Stage number as shown on the approved power plan
  - Voltage Rating of equipment
  - Pad Number of the equipment being tested
  - Manufacturer & Description of the type of equipment
  - Equipment rating

#### 4.8 Primary Cable Testing Requirements and Witnessing

- 4.8.1 Very low frequency (VLF) testing is the approved acceptance test for testing of cable and cubicles for Volume 7 - City of Edmonton Design and Construction Standards. Contact EDTI Land Servicing for a copy of the most current version of EDTI Operating Procedure TS 09 - Test Underground Cable.
- 4.8.2 Ground resistance testing is required on all padmounted equipment. Results should specify which method of testing was used (e.g., clip-on or 3-point).
- 4.8.3 EDTI requires a monitored withstand acceptance test with current readings recorded every minute for 60 minutes. If any sufficient variance of current recordings exists, the test must continue for the full 60 minutes. Test voltages are as per Table 3 of the IEEE Std. 400.2-2013. Test results shall be submitted to EDTI at [LandServicing@epcor.com](mailto:LandServicing@epcor.com).
- 4.8.4 All primary XLPE and EPR cables are to be tested. Any sections of cables or elbows that fail this test will be removed and replaced with new material or repaired to the satisfaction of the EDTI Powerline Technician. The Contractor will ensure that all tests are carried out in accordance with the rules and regulations, as described in the current AEUC, the EDTI Standard for testing cable and any other applicable standard or safety code.
- 4.8.5 EDTI will not witness the tests. The cable testing contractor, contractor, and the consultant must sign the test reports prior to submission to EDTI Land Servicing.
- 4.8.6 The contractor performing the tests is responsible for carrying out safe work practices and to ensure the safety of the general public, EDTI Underground Tradesperson and colleagues and safety of the contractor performing the test.
- 4.8.7 The contractor is responsible for continuity checks to ensure that the cable routing follows the approved schematic. The cable route is to be recorded on the test reports and will include the typical "LA", "LC" transformer bushing designation or switch compartment letter and phase c/w the pad number as a reference. Cables intended to be capped in pits or bases are to be identified by their location on the test reports and cross referenced to the approved schematic.

#### 4.9 General Cable Test Requirements

- 4.9.1 Very low frequency (VLF) testing is the approved acceptance test for testing of cable and cubicles. All cable testing to be completed as per EDTI Testing Procedure TS 09 - Test Underground Cable. Contact EDTI Land Servicing for a copy of the most current version.
- 4.9.2 Elbows on cables to be tested are to be parked on a double parking stand where feed-thru connections on transformers are or to bypass cubicles to ensure the interconnection of the cables prior to testing.
- 4.9.3 Temporary stress cones, taping or temporary boots, to prevent corona may be necessary on cable ends.
- 4.9.4 Discharging of the cable after completion of the test must be done in such a manner as to reduce the damage to the cable. A test jumper should be used to discharge any existing potential. The cable or cable system should not be discharged if it still has a residual voltage. The tested conductor should be left grounded for at least one minute for every kV of test voltage or for at least the same amount of time it was energized under the test, whichever period is longer.
- 4.9.5 Cables are to be tested to the test voltages specified in Table 1 of the EDTI procedure (Table 3 of IEEE Std. 400.2-2013).
- 15 kV cables are to be tested to 21 kV (sinusoidal) or 30 kV (cosine-rectangular) for the acceptance test.
  - 25 kV cables are to be tested to 32 kV (sinusoidal) or 45 kV (cosine-rectangular) for the acceptance test.

#### 4.10 Equipment Testing Requirements and Witnessing

- 4.10.1 Transformers shall be tested by the manufacturer according to the approved standard Can/CSA-C2.1-06 (R2011) or newer. At EDTI's discretion, EDTI may request a copy of the test report, certified by the

manufacturer, acknowledging that all routine tests have been performed. It is the contractor's responsibility to provide copies of these test reports.

- 4.10.2 EDTI reserves the right to request copies of manufacturer's test reports and specifications for any transformers or switching cubicles purchased where EDTI does not already have this information on hand. The reason for this is to ensure that the equipment meets EDTI specifications and is identical to existing equipment in EDTI's distribution system and meets current EDTI standards. Any equipment, which does not meet these requirements, may need to be replaced and is at the discretion of EDTI Land Servicing, the EDTI Underground Tradesperson or EDTI Underground Trades Foreman.
- 4.10.3 Depending on the supplier of transformers, EDTI may request copies of the test reports from the factory (the contractor must supply these reports prior to energization of these transformers or EDTI may request a field test of the transformers).
- 4.10.4 Switching cubicle or transformer test reports must include the following data:
- Subdivision Name and Stage number as shown on the approved power plan
  - Current Temperature the day of the test
  - Current Humidity the day of the test
  - Maximum Test Voltage
  - Duration of Test in minutes
  - Voltage Rating of equipment
  - Pad Number of the equipment being tested
  - Manufacturer & Description of the type of equipment
  - Equipment Rating
  - Contact Resistance Test (for cubicles only)
  - Name of the Contractor who completed all electrical terminations/connections as well as the names of the individuals who completed the terminations/connections
  - For switching cubicles, the type of fuse holder(s) provided for each switch, as applicable for each switching cubicle

#### 4.11 Upon Completion of Testing

- 4.11.1 Immediately after testing, 600 amp window opening reducing tap plugs must be torqued to 55 ft-lbs to secure the 400/600 amp elbows and all connections made ready for energization. An EDTI Underground Tradesperson will install parking stands where terminations are to be disconnected or install ground elbows on 400/600 amp terminations (i.e. primary cables are capped outside of the cubicle waiting for future development and cannot be energized).
- 4.11.2 Immediately after testing, all 200 amp elbows must be solidly seated on the appropriate bushing.
- 4.11.3 Cable test reports, cubicle test reports, transformer test reports, and ground grid resistance reports are to be reviewed, signed off by the testing company and the Contractor, and submitted via the EDTI Land Servicing inbox ([landservicing@epcor.com](mailto:landservicing@epcor.com)).

Immediately after testing, heat shrink cable caps are to be installed on the ends of all primary cable. (Refer to EDTI Underground Distribution Standard 6600070048175 for heat-shrink caps.) Test reports are to include the name(s) of the Contractor's tradesperson(s) who completed the terminations/connections.

**XLPE PRIMARY CABLE- 15kV**

STOCK NO.	CABLE SIZE	CONDUCTOR TYPE	NEUTRAL	SINGLE/ TRIPLEXED CONDUCTOR	NO. OF CABLES	NOMINAL OUTER JACKET DIA.		RISER / ROAD CROSSING	
						mm	in	MIN. DUCT SIZE	
								mm	in
46339	1/0	AL	JCN	SINGLE	1-1/C	27.4	1.08	100**	4**
					2-1/C	-	-	100	4
					3-1/C	-	-	100	4
14621	500 MCM	CU	JCN	SINGLE	1-1/C	38.2	1.50	150	6
					3-1/C	-	-	150	6
32501	500 MCM	CU	JCN	TRIPLEX	3-1/C	* 38.2	* 1.50	150***	6***
<del>10194</del>	<del>750 MCM</del>	<del>CU</del>	<del>JCN</del>	<del>TRIPLEX</del>	<del>3-1/C</del>	<del>* 45.2</del>	<del>* 1.78</del>	<del>150</del>	<del>6</del>

**XLPE PRIMARY CABLE- 25kV**

STOCK NO.	CABLE SIZE	CONDUCTOR TYPE	NEUTRAL	SINGLE/ TRIPLEXED CONDUCTOR	NO. OF CABLES	NOMINAL OUTER JACKET DIA.		RISER / ROAD CROSSING	
						mm	in	MIN. DUCT SIZE	
								mm	in
04934	1/0	AL	JCN	SINGLE	1-1/C	31.7	1.25	100**	4**
					2-1/C	-	-	100	4
					3-1/C	-	-	100	4
69903	500	AL	JCN	SINGLE	1-1/C	43.6	1.72	150	6
					3-1/C	-	-	150	6

**EPR PRIMARY CABLE- 15kV**

STOCK NO.	CABLE SIZE	CONDUCTOR TYPE	NEUTRAL	SINGLE/ TRIPLEXED CONDUCTOR	NO. OF CABLES	NOMINAL OUTER JACKET DIA.		RISER / ROAD CROSSING	
						mm	in	MIN. DUCT SIZE	
								mm	in
15175	2/0	CU	JCN	TRIPLEX	3-1/C	* 30.2	* 1.19	100	4
17197	750 MCM	CU	FN	TRIPLEX	3-1/C	* 38.5	* 1.52	150***	6***
<del>11297</del>	<del>750 MCM</del>	<del>CU</del>	<del>LC</del>	<del>TRIPLEX</del>	<del>3-1/C</del>	<del>* 41.7</del>	<del>* 1.64</del>	<del>100</del>	<del>4</del>

**EPR PRIMARY CABLE- 28kV**

STOCK NO.	CABLE SIZE	CONDUCTOR TYPE	NEUTRAL	SINGLE/ TRIPLEXED CONDUCTOR	NO. OF CABLES	NOMINAL OUTER JACKET DIA.		RISER / ROAD CROSSING	
						mm	in	MIN. DUCT SIZE	
								mm	in
13158	750 MCM	CU	JCN	TRIPLEX	3-1/C	* 50.4	* 1.99	150	6
13148	750 MCM	CU	JCN	SINGLE	1-1/C	50.4	1.99	150	6
					3-1/C	-	-	150	6

\* NOMINAL OUTER JACKET DIAMETER STATED IS FOR A SINGLE CONDUCTOR ONLY.  
 \*\* 2" DUCT MAY BE ACCEPTABLE, FURTHER ENGINEERING ANALYSIS IS REQUIRED.  
 \*\*\* FOR EXISTING INSTALLATIONS 4" DUCTS MAY BE USED.

**VOLUME 7 - C.O.E.  
 DESIGN & CONSTRUCTION  
 STANDARDS**

REVIEWED BY STANDARDS  
 COMMITTEE: 2016-08-09  
 DRAFTED BY: R. LAWRIE  
 DESIGNED BY: A. RAHMAN  
 SCALE: N. T. S.  
 DATE REVISED: 2016-09-22



**DUCT SIZE FOR  
 PRIMARY ROAD CROSSINGS  
 AND RISERS**

STANDARD NO.  
**63 00 07 00 37 001**

PAGE NO.  
 1 / 2

20170601 15:53 r lawrie



NOTES:

1. ROAD CROSSING WITH DUCT IS DEFINED AS A STRAIGHT CROSSING OF THE ROADWAY, DIRECTLY FROM ONE SIDE TO THE OTHER SIDE FREE FROM ANY INTERMEDIATE BENDS.
2. RISER BEND DIAMETER SHALL HAVE THE SAME DIAMETER AS THE ROAD CROSSING DUCT FOR NEW INSTALLATIONS.
3. RADIUS FOR CONDUIT ELBOWS SHALL BE HIGHER THAN THE MINIMUM CABLE BENDING RADIUS (PULLING) ACCORDING TO STANDARD 63 00 07 00 47 002.

**OBSOLETE**

**VOLUME 7 - C.O.E.  
DESIGN & CONSTRUCTION  
STANDARDS**

REVIEWED BY STANDARDS  
COMMITTEE: 2016-08-09

DRAFTED BY: R. LAWRIE

DESIGNED BY: A. RAHMAN

SCALE: N. T. S.

DATE REVISED: 2016-09-22



**DUCT SIZE FOR  
PRIMARY ROAD CROSSINGS  
AND RISERS**

STANDARD NO.

**63 00 07 00 37 001**

PAGE NO.

2 / 2

**UNDERGROUND SINGLE PHASE SECONDARY USEB CABLES - FOR U. R. D.**

STOCK NO.	CABLE SIZE	CONDUCTOR TYPE	NEUTRAL	NO. OF CABLES	NOMINAL OUTER DIMENSIONS		ROAD CROSSING & RISER	
					mm	in	MIN. DUCT SIZE	mm
30216	4	AL	JCN	1-2/C	14.9 x 22.8	0.59 x 0.90	100	2
				2-2/C			100	4
				3-2/C			100	4
				4-2/C			100	4
22532	2	AL	JCN	1-2/C	16.3 x 25.6	0.64 x 1.01	100	2
				2-2/C			100	4
				3-2/C			100	4
				4-2/C			100	4
80898	1/0	AL	JCN	1-2/C	18.5 x 30.0	0.73 x 1.18	100	2
				2-2/C			100	4
				3-2/C			100	4
				4-2/C			150	6
51879	2/0	AL	JCN	1-2/C	19.6 x 32.2	0.77 x 1.27	100	4
				2-2/C			100	4
				3-2/C			100	4
				4-2/C			150	6
80902	4/0	AL	JCN	1-2/C	22.8 x 37.8	0.90 x 1.49	100	4
				2-2/C			100	4
				3-2/C			150	6

**UNDERGROUND SECONDARY XLPE CABLES - FOR NETWORK**

STOCK NO.	CABLE SIZE	CONDUCTOR TYPE	NEUTRAL	NO. OF CABLES	NOMINAL OUTER DIMENSIONS		ROAD CROSSING & RISER	
					mm	in	MIN. DUCT SIZE	mm
41872	4/0	CU	N/A	1-7/C	62.0	2.44	100	4
28886	4/0	CU	N/A	1-1/C	18.7	0.74	100	4
50151	500 MCM	CU	N/A	1-1/C	29.2	1.15	100	4

**NOTE:**

1. ROAD CROSSING WITH DUCT IS DEFINED AS A STRAIGHT CROSSING OF THE ROADWAY, DIRECTLY FROM ONE SIDE TO THE OTHER SIDE FREE FROM ANY INTERMEDIATE BENDS.
2. RISER BEND DIAMETER SHALL HAVE THE SAME DIAMETER AS THE ROAD CROSSING DUCT FOR NEW INSTALLATIONS.
3. ALL BENDS SHOULD BE RIGID PVC.

**VOLUME 7 - C.O.E.  
DESIGN & CONSTRUCTION  
STANDARDS**

REVIEWED BY STANDARDS  
COMMITTEE: 2016-08-09  
DRAFTED BY: R. LAWRIE  
DESIGNED BY: A. RAHMAN  
SCALE: N. T. S.  
DATE REVISED: 2016-09-12



**DUCT SIZE FOR  
SECONDARY ROAD CROSSINGS  
AND RISERS**

STANDARD NO.  
**63 00 07 00 37 002**

PAGE NO.  
1 / 1

20170601 16:00 r lawrie

CABLE PULLING INSTRUCTIONS :

- 1) PRIOR TO CABLE PULLING THE DUCT SHALL BE THOROUGHLY CLEANED AND SWABBED. THE DUCT SHALL BE TEST PROOFED TO CONFIRM ITS INTEGRITY. ENSURE THAT NO BURRS OR OBSTRUCTIONS ARE PRESENT IN THE CONDUIT.
- 2) WHEN POSSIBLE THE DIRECTION OF PULL SHOULD BE TOWARD THE LOCATION THAT IS FARTHEST FROM ANY BENDS THAT THE CABLE MUST BE PULLED THROUGH.

EXAMPLE :

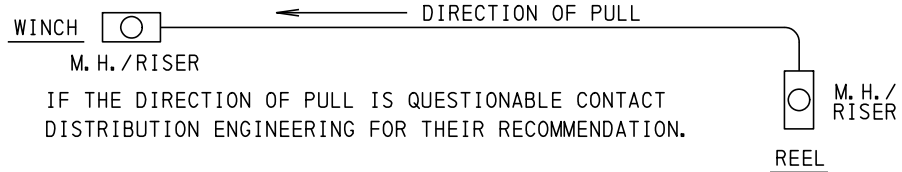

- 3) TYPICAL UNLUBRICATED STATIC COEFFICIENT OF FRICTION (COF) FOR EPCOR STANDARD CABLE WITH LLDPE JACKET IN PVC DUCT IS 0.4. CALCULATE USING THE APPROPRIATE LUBRICANT COF AS REQUIRED.
- 4) CABLE LUBRICATION SHOULD BE USED AND APPLIED ACCORDING TO THE MANUFACTURERS RECOMMENDATIONS. APPROVED LUBRICANTS ARE: EPCOR STOCK# 38880 (SUMMER GRADE) AND 88821 (WINTER GRADE).
- 5) CABLES SHOULD BE PULLED THROUGH DUCTS AT A CONSTANT SPEED THROUGHOUT THE ENTIRE PULL. THE RECOMMENDED PULLING SPEED IS 40 TO 50 FEET PER MINUTE.
- 6a) A DYNAMOMETER SHOULD BE USED AND THE MAXIMUM PULLING TENSIONS LISTED SHOULD NOT BE EXCEEDED. A WINCH MOUNTED DYNAMOMETER IS PREFERRED. IF A WINCH MOUNTED DYNAMOMETER IS NOT AVAILABLE THEN USE A PORTABLE DYNAMOMETER.
- 6b) 1/0 ALUMINUM 15 AND 25 kV CABLES ARE EXEMPT FROM THE NOTE 6a REQUIREMENT IN SOME CASES. SEE NOTE 6 ON PAGE 2.
- 7) IN INSTANCES WHERE THE REQUIREMENTS OF THE CANADIAN ELECTRICAL CODE REGARDING DUCT FILL DO NOT APPLY (I.E. UTILITY), THEN THE CLEARANCE BETWEEN THE CABLE AND THE CONDUIT SHOULD BE CHECKED. THIS CLEARANCE SHOULD NOT BE LESS THAN 1.25cm OR 1/2 INCH. WHERE LC SHIELD EPR CABLE IS INSTALLED IN A 4 INCH DUCT THIS RECOMMENDATION CANNOT BE MET.
- 8) THE FOLLOWING TABLES LIST THE MAXIMUM PULLING TENSIONS THAT CAN BE APPLIED TO THE CABLE WITHOUT CAUSING DAMAGE. WHERE THE PULLING TENSIONS PERMITTED BY CABLE GRIPS ARE LIKELY TO BE EXCEEDED THEN A PULLING EYE SHOULD BE FITTED.
- 9) SHEAVES SHALL HAVE A RADIUS NO LESS THAN 36 INCHES. PULLING CABLES AROUND SMALLER SHEAVES THAN THIS MAY RESULT IN PERMANENT DAMAGE TO THE CABLE.
- 10) THE LOAD RATING OF ALL CHAINS, SHEAVES, ANCHORS ETC. SHOULD BE CHECKED PRIOR TO PULLING TO ENSURE THAT THEIR RATING IS NOT EXCEEDED.

20170601 16:15 r lawrie

<p><b>VOLUME 7 - C.O.E. DESIGN &amp; CONSTRUCTION STANDARDS</b></p>		<p><b>INSTALLATION &amp; PULLING OF XLPE AND EPR CABLES</b></p>
<p>REVIEWED BY STANDARDS COMMITTEE: 2013-01-22</p> <p>DRAFTED BY: R. LAWRIE</p> <p>DESIGNED BY: A. RAHMAN</p> <p>SCALE: N. T. S.</p> <p>DATE REVISED: 2015-06-25</p>		<p>STANDARD NO. <b>63 00 07 00 47 002</b></p> <p>PAGE NO. 1 / 2</p>

**PRIMARY UNDERGROUND CABLE PULLING DATA**

STOCK NO.	CABLE SIZE & SPECIFICATION	CABLE OUTER DIA.		WEIGHT		MIN. BENDING RADIUS		MAX. PULLING TENSION LISTED IN KELLUM GRIP <sup>®</sup>	MAX. PULLING TENSION LISTED IN PULLING EYE	MAXIMUM STEADY STATE WORKING PRESSURE					
		mm	in	kg/m	lbs/ft	DRESSING	PULLING			N	lbs	kg/m	lbs/ft		
46339	1/0 AL 15 KV XLPE CN-J SINGLE CONDUCTOR	27.4	1.08	0.950	0.638	329	13.0	493	19.4	2820	634	N/A	N/A	1488	1000
04934	1/0 AL 25 KV XLPE CN-J SINGLE CONDUCTOR	31.7	1.25	1.14	0.764	380	15.0	571	22.5	2820	634	N/A	N/A	1488	1000
15175	2/0 CU 15 KV EPR CN-J TRIPLEXED	30.2	1.19	1.50	1.01	457	18.0	652	25.7	4450	1000	13340	3000	1488	1000
14621	500 MCM CU 15 KV XLPE CN-J SINGLE CONDUCTOR	38.2	1.50	3.88	2.61	458	18.0	688	27.1	4450	1000	24470	5500	1488	1000
69903	500 MCM AL 25 KV XLPE CN-J SINGLE CONDUCTOR	43.6	1.72	2.32	1.56	523	20.6	785	30.9	4450	1000	13340	3000	1488	1000
13148	750 MCM CU 28 KV EPR CN-J SINGLE CONDUCTOR	50.4	1.99	6.29	4.23	605	23.8	908	35.7	4450	1000	26690	6000	1488	1000
32501	500 MCM CU 15 KV XLPE CN-J TRIPLEXED	38.2	1.50	3.88	2.61	578	22.8	823	32.4	4450	1000	35590	8000	1488	1000
10194	750 MCM CU 15 KV XLPE CN-J TRIPLEXED	45.2	1.78	5.73	3.85	684	26.9	974	38.3	4450	1000	44480	10000	1488	1000
11297	750 MCM CU 15 KV EPR LC-J TRIPLEXED	41.7	1.64	4.79	3.22	631	24.8	899	35.4	4450	1000	44480	10000	1488	1000
17197	750 MCM CU 15 KV EPR FN-J TRIPLEXED	38.5	1.52	4.60	3.10	665	26.2	832	32.8	4450	1000	44480	10000	1488	1000
13158	750 MCM CU 28 KV EPR CN-J TRIPLEXED	50.4	1.99	6.29	4.23	762	30	1087	42.8	4450	1000	44480	10000	1488	1000

**NOTE:**

- 1) THE ABOVE TABLE SHOWS MAXIMUM CABLE TENSIONS ONLY.
- 2) THE CONDITION OF PULLING EYES AND ANY HARDWARE TO BE USED IN THE PULL SHOULD BE THOROUGHLY CHECKED BEFORE ATTEMPTING THE PULL. ANY DEFECTIVE EQUIPMENT SHOULD BE REPLACED.
- 3) THE PREFERRED PULLING METHOD IS BY USING PULLING EYES.
- 4) THE ABOVE PULLING TENSIONS ARE FOR STRAIGHT PULLS ONLY. FOR PULLS WITH BENDS OR MULTIPLE BENDS CONTACT DISTRIBUTION ENGINEERING FOR MAXIMUM SAFE PULLING TENSIONS.
- 5) TYPICAL REEL "BACK" PRESSURE IS 445 N (100 lbs).
- 6) A GENERAL CASE FOR 1/0 AL 15 KV OR 25KV IS: THE MAXIMUM ALLOWABLE RUN FROM END TO END WITH UP TO TWO 90 DEGREE BENDS (PEDESTAL TO PEDESTAL, PEDESTAL TO LATERAL OR LATERAL TO LATERAL; WHERE A PEDESTAL IS ANY TRANSFORMER OR SWITCHING CUBICLE AND A LATERAL IS A POLE 50 FT IN HEIGHT) IS 350 m. EACH ADDITIONAL BEND WILL REDUCE THE MAXIMUM ALLOWABLE RUN BY 100 m.
- 7) THE MAXIMUM PULLING TENSIONS PROVIDED FOR TRIPLEXED CABLES ARE FOR THE 3 CABLE ASSEMBLY.

**VOLUME 7 - C.O.E.  
DESIGN & CONSTRUCTION  
STANDARDS**

REVIEWED BY STANDARDS COMMITTEE: 2013-01-22  
 DRAFTED BY: R. LAWRIE  
 DESIGNED BY: A. RAHMAN  
 SCALE: N. T. S.  
 DATE REVISED: 2015-06-25



**INSTALLATION & PULLING  
OF XLPE AND EPR CABLES**

STANDARD NO.

63 00 07 00 47 002

PAGE NO.

2 / 2

PRIMARY CABLES USED IN DISTRIBUTION CONSTRUCTION

PRIMARY CABLE - 15 KV

STOCK NO.	SIZE	CONDUCTOR ALLOY	STRAND CONFIG.	INSULATION TYPE	NEUTRAL RATING	NEUTRAL TYPE	SPECIFICATION NO.	DESCRIPTION/APPLICATION
46339	1/0	AL	COMPRESSED	XLPE	100%	CN	6600051545002	STANDARD 15 KV URD CABLE ( SINGLE CONDUCTOR)
15175	2/0	CU	COMPACT	EPR	33%	CN	6600051583002	STANDARD 15 KV NETWORK CABLE ( TRIPLEXED)
14621	500 MCM	CU	COMPACT	XLPE	33%	CN	6300051582001	STANDARD 15 KV DIRECT BURIAL, SINGLE CONDUIT UJD AND TRUNK CABLE ( SINGLE CONDUCTOR)
32501	500 MCM	CU	COMPACT	XLPE	33%	CN	6300051582001	15 KV DIRECT BURIAL, SINGLE CONDUIT UJD AND TRUNK CABLE ( TRIPLEXED)
17197	750 MCM	CU	COMPACT	EPR	33%	FN	6300051583003	STANDARD 15 KV TRUNK CABLE, IN CONDUIT AND DIRECT BURIAL ( TRIPLEXED) ***
10194	750-MCM	CU	COMPACT	XLPE	33%	GN	6300051582001	STANDARD 15 KV TRUNK CABLE, IN CONDUIT ( TRIPLEXED)
11297	750-MCM	CU	COMPACT	EPR	33%	LC	6300051583001	LIMITED USE FOR TRUNK CABLE INSTALLED IN EXISTING 4" CONDUITS ONLY. LC SHIELD EPR REQUIRE A COMPANION NEUTRAL 4/0 INSULATED CABLE ( TRIPLEXED)

PRIMARY CABLE - 25 KV

STOCK NO.	SIZE	CONDUCTOR ALLOY	STRAND CONFIG.	INSULATION TYPE	NEUTRAL RATING	NEUTRAL TYPE	SPECIFICATION NO.	DESCRIPTION/APPLICATION
04934	1/0	AL	COMPRESSED	XLPE	100%	CN	6600052545001	STANDARD 25 KV URD AND UJD CABLE ( SINGLE CONDUCTOR)
69903	500 MCM	AL	COMPACT	XLPE	33%	CN	6600052545001	25 KV DIRECT BURIAL AND SINGLE CONDUIT BRANCH CABLE ONLY ( SINGLE CONDUCTOR)
13158	750 MCM	CU	COMPACT	EPR	33%	CN	6300052883001	STANDARD 25 KV TRUNK CABLE IN CONDUIT ( TRIPLEXED)
13148	750 MCM	CU	COMPACT	EPR	33%	CN	6300052883001	25 KV TRUNK CABLE FOR SUBSTATION EXIT IN CONCRETE DUCTLINE, DIRECT BURIAL OR SINGLE CONDUCTOR IN SINGLE CONDUIT INSTALLATION IN SPECIAL CASES **

\* SHIELD FAULT CURRENT RATING: 8 CYCLES - 15, 628A, 15 CYCLES - 11, 409A, 1 SECOND - 5, 705A, 2 SECONDS - 4, 034A  
 \*\* POOR SOIL CONDITIONS, CABLE SEPARATION  
 \*\*\* REPLACES 750 MCM LC SHIELD ( NO COMPANION NEUTRAL REQUIRED)

VOLUME 7 - C.O.E.  
 DESIGN & CONSTRUCTION  
 STANDARDS

REVIEWED BY STANDARDS COMMITTEE: 2012-11-16  
 DRAFTED BY: R. LAWRIE  
 DESIGNED BY: A. RAHMAN  
 SCALE: N. T. S.  
 DATE REVISED: 2015-07-14



PRIMARY UNDERGROUND CABLES  
 USED IN  
 DISTRIBUTION CONSTRUCTION

STANDARD NO.  
 63 00 07 00 82 001

PAGE NO.  
 1 / 1

SECONDARY CABLES USED IN UNDERGROUND CONSTRUCTION  
600 VOLT - SECONDARY CABLE

STOCK #	SIZE	CONDUCTOR ALLOY	NEUTRAL TYPE	STRAND CONFIG.	NEUTRAL RATING (%)	TYPICAL REEL LENGTH	SPECIFICATION #	SINGLE CABLE WEIGHT (lb/ft)	NOMINAL OUTER JACKET DIMENSION (mm)	DESCRIPTION/APPLICATION
030216	#4	AL	JCN	COMPRESSED	70	900 m	6600050822005	0.277	14.3 X 22.2 (mm)	USEB90 - STANDARD STREETLIGHTING CABLE
022532	#2	AL	JCN	COMPRESSED	70	900 m	6600050822005	0.427	16.3 X 25.6 (mm)	USEB90 - OLD STANDARD RESIDENTIAL SERVICE CABLE (100 AMP SERVICE)
051879	2/0	AL	JCN	COMPRESSED	70	700 m	6600050822005	0.655	19.6 X 32.2 (mm)	USEB90 - RESIDENTIAL SERVICE CABLE (150 AMP)
080898	1/0	AL	JCN	COMPRESSED	70	750 m	6600050822005	0.520	18.5 X 30.0 (mm)	USEB90 - NEW STANDARD RESIDENTIAL SERVICE CABLE (100 AMP SERVICE)
030216	4	AL	JCN	COMPRESSED	70	900 m	6600050822005	0.277	14.4 X 22.2 (mm)	USEB90 - STANDARD STREETLIGHTING CABLE
080902	4/0	AL	JCN	COMPRESSED	70	500m	6600050822005	0.991	22.8 X 37.8 (mm)	USEB90 - RESIDENTIAL SERVICE CABLE (200 AMP)
041872	4/0	Cu	500 Cu							7/C NETWORK SERVICE CABLE *
050151	500	Cu	NONE	COMPRESSED	NONE					RW90 - DOUBLE JACKETED CABLE USED IN DUCTLINE**

1000 VOLT - SECONDARY CABLE

STOCK #	SIZE	CONDUCTOR ALLOY	NEUTRAL TYPE	STRAND CONFIG.	NEUTRAL RATING (%)	TYPICAL REEL LENGTH	SPECIFICATION #	SINGLE CABLE WEIGHT (lb/ft)	NOMINAL OUTER JACKET DIMENSION (mm)	DESCRIPTION/APPLICATION
037409	4/0	Cu								RW90 - SOME GROUNDING APPLICATIONS - PVC JACKET

CABLE STOCKED BUT NO LONGER PURCHASED

STOCK #	SIZE	CONDUCTOR ALLOY	NEUTRAL TYPE	STRAND CONFIG.	NEUTRAL RATING (%)	TYPICAL REEL LENGTH	SPECIFICATION #	SINGLE CABLE WEIGHT (lb/ft)	NOMINAL OUTER JACKET DIMENSION (mm)	DESCRIPTION/APPLICATION
029709	#14					312m				3 CONDUCTOR - SJTW
041293	4/0	AL	JCN	COMPRESSED	100	500m	6600050822005	1.083	23.6 X 38.8 (mm)	USEB90 - RESIDENTIAL SERVICE CABLE
040087	350	AL	JCN	COMPRESSED						USEB90 - FOR REPAIRS ONLY
038439	400	AL	JCN	COMPRESSED						USEB90 - FOR REPAIRS ONLY

NOTE:

- \* 7/C NETWORK SERVICE CABLE IS 6 X 4/0 COPPER CONDUCTORS WITH 1 X 500 COPPER NEUTRAL
- \*\* THIS CABLE IS SPECIFIC TO THE DUCTLINE AND MUST BE DOUBLE JACKETED (PVC JACKET)

VOLUME 7 - C.O.E.  
DESIGN & CONSTRUCTION  
STANDARDS

REVIEWED BY STANDARDS  
COMMITTEE: 2003-10-16

DRAFTED BY: RINGO TSANG

DESIGNED BY: GARY EGGEN

SCALE: N. T. S.

DATE REVISED: 2010-06-03



UNDERGROUND SECONDARY CABLE  
XLPE

STANDARD NO.

63 00 07 00 82 002

PAGE NO.

1 / 1

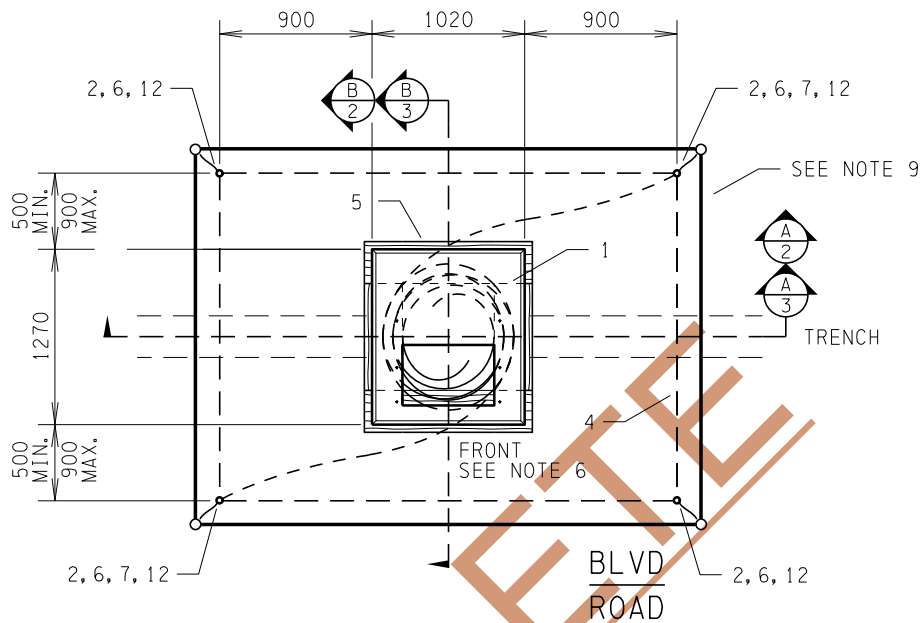

TOP VIEW  
SCALE: N.T.S.

**NOTES:**

1. INTERCONNECTING GRADIENT CONTROL (GROUND GRID) CONDUCTORS SHALL BE INSTALLED 300 mm BELOW FINAL FINISHED GRADE (NOT ROUGH GRADE) WITH ONE LEG CONTINUOUS AROUND THE PERIMETER AND INTO BASE WITH AN ADDITIONAL CONTINUOUS CONDUCTOR TAIL ATTACHED FROM THE OPPOSITE CORNER.
2. RETAIN 5.0 m OF COILED 4/0 CU PER GROUND CONDUCTOR FOR CONNECTION TO GROUND BUS.
3. USE FINE FILL CLAY BACKFILL AROUND GROUND GRID.
4. WHEN SETTING BASE OBSERVE 150 mm MIN. - 200 mm MAX. REQUIREMENT FOR ELEVATION FROM TOP OF BASE TO FINAL FINISHED GRADE (NOT ROUGH GRADE).
5. TYPICAL RESIDENTIAL INSTALLATION IS DIRECT BURIED.
6. IN RESIDENTIAL AREAS IT IS PREFERRED TO HAVE THE FRONT FACING THE ROADWAY.
7. IN DIRECT BURIED APPLICATION, ONCE MOUSEHOLES ARE FULL EXTRA CABLES SHOULD BE ADDED USING CONDUIT AS DEPICTED IN COMMERCIAL/INDUSTRIAL/MULTI-FAMILY APPLICATION VIEWS (SEE PAGE 3).
8. FOR COMMERCIAL/INDUSTRIAL/MULTI-FAMILY APPLICATIONS ALL CABLES SHOULD ENTER BASE VIA CONDUIT.
9. FOR COMMERCIAL/INDUSTRIAL/MULTI-FAMILY APPLICATIONS STEEL GUARD RAILS ARE REQUIRED .
10. PIPE DUCT (ITEM 3) LENGTH SHALL EXTEND BEYOND GROUND GRID ZONE AS SHOWN.
11. FOR CABLE BYPASS TROUGH REQUIREMENTS AND INSTALLATION SEE DRAWING 66 00 07 00 46 005.
12. ALL CABLES SHALL HAVE A MINIMUM OF 5.0 m OF EXTRA CABLE COILED IN BASE AS MEASURED FROM THE TOP OF PIPE OR THE BASE ENTRY POINT.
13. THE BASE SHALL BE INSTALLED SUCH THAT THE TOP SURFACE IS LEVEL.
14. BASE WEIGHT: 860 kg (1895 lbs).

ALL DIMENSIONS IN MILLIMETERS ( INCHES) UNLESS OTHERWISE SPECIFIED.

<b>VOLUME 7 - C.O.E.</b> <b>DESIGN &amp; CONSTRUCTION</b> <b>STANDARDS</b>		<b>INSTALLATION OF</b> <b>PRECAST CONCRETE BASE FOR</b> <b>SINGLE PHASE TRANSFORMERS</b>	
REVIEWED BY STANDARDS COMMITTEE: 2017-05-26		STANDARD NO.	PAGE NO.
DRAFTED BY: R. LAWRIE		<b>66 00 07 00 27 115</b>	<b>1 / 7</b>
DESIGNED BY: A. RAHMAN			
SCALE: N. T. S. DATE REVISED: 2017-06-30			

20170705 13:20 r lawrie

DIRECT BURIED APPLICATION

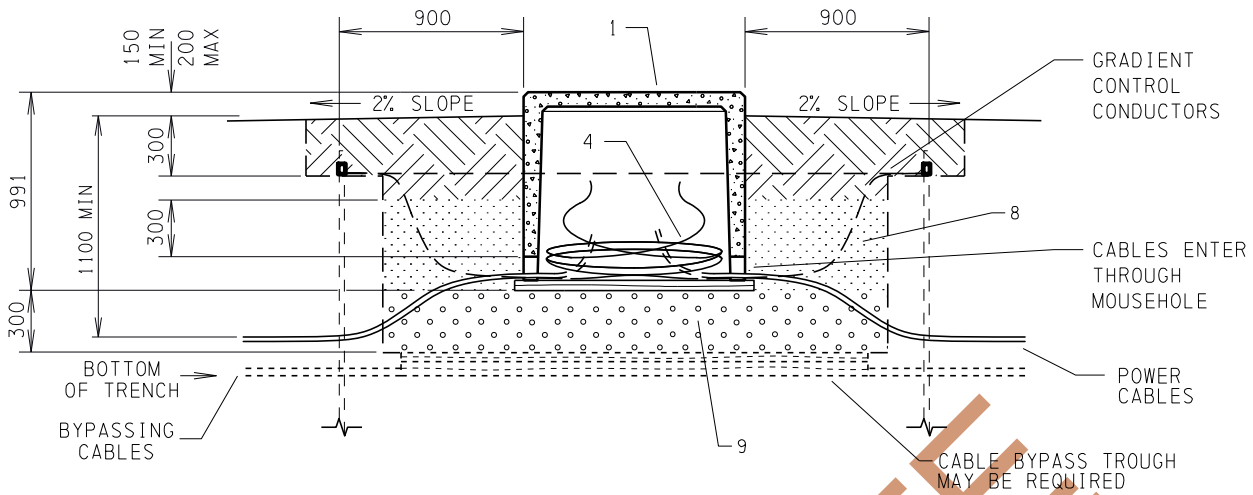

(A) SECTION A-A  
SCALE: N.T.S.

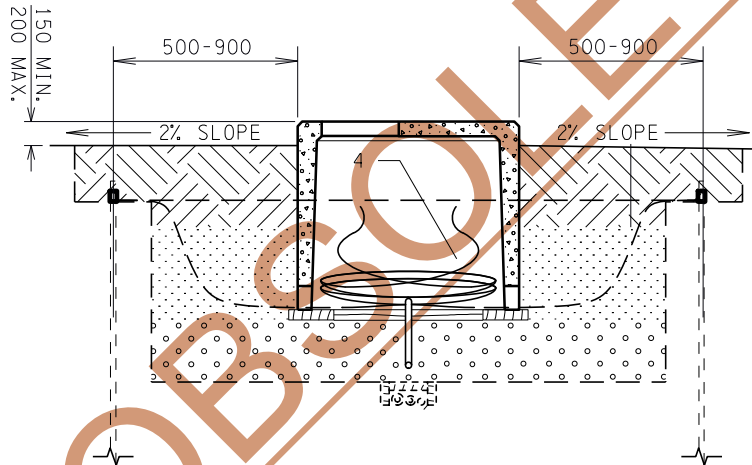

(B) SECTION B-B  
SCALE: N.T.S.

NOTES CONT'D:

15. STEP THE EXCAVATION FOR THE BASE LEAVING A SHELF 300 mm BELOW FINISHED GRADE, ALLOWING FOR THE INSTALLATION OF THE GROUND RODS IN UNDISTURBED CLAY.
16. LEVEL THE FOUNDATION BOARDS ON 300 mm OF COMPACTED ROAD CRUSH BEFORE SETTING THE BASE.
17. SAND 300 mm ABOVE THE MOUSE HOLES AFTER CABLE INSTALLATION.
18. BACKFILL WITH 300 mm LIFTS OF CLAY OR NATIVE SOIL AND COMPACT TO ROUGH GRADE.

ALL DIMENSIONS IN MILLIMETERS (INCHES) UNLESS OTHERWISE SPECIFIED.

VOLUME 7 - C.O.E.  
DESIGN & CONSTRUCTION  
STANDARDS

REVIEWED BY STANDARDS  
COMMITTEE: 2017-05-26  
DRAFTED BY: R. LAWRIE  
DESIGNED BY: A. RAHMAN  
SCALE: N. T. S.  
DATE REVISED: 2017-06-30



INSTALLATION OF  
PRECAST CONCRETE BASE FOR  
SINGLE PHASE TRANSFORMERS

STANDARD NO.

66 00 07 00 27 115

PAGE NO.

2 / 7



COMMERCIAL/ INDUSTRIAL/MULTI-FAMILY APPLICATION

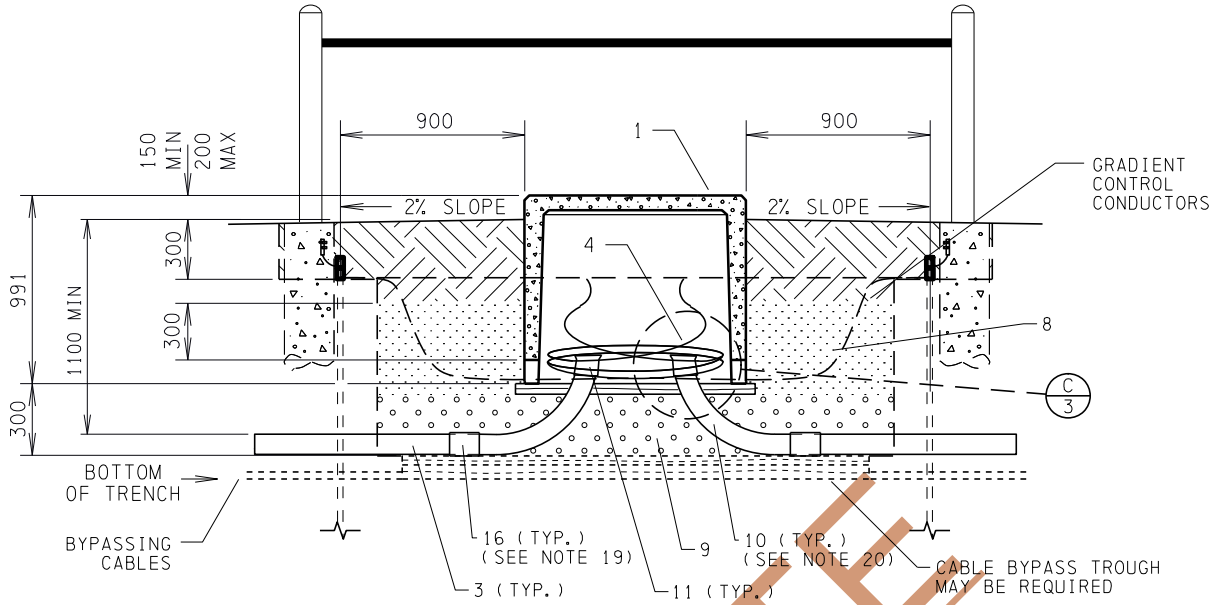

**A** SECTION A-A  
SCALE: N.T.S.

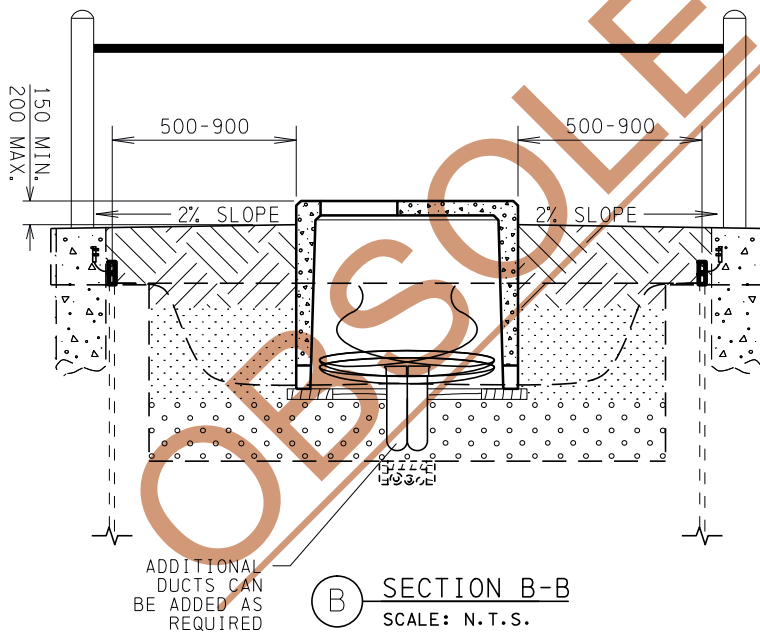

**B** SECTION B-B  
SCALE: N.T.S.

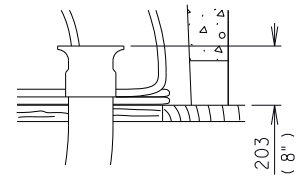

**C** DETAIL  
SCALE: N.T.S.

NOTES CONT'D:

- 19. ADAPTER COUPLING IS REQUIRED FOR DB2 CONDUIT.
- 20. 36" RADIUS BENDS ARE PREFERRED FOR ALL DUCT BENDS.

ALL DIMENSIONS IN MILLIMETERS ( INCHES ) UNLESS OTHERWISE SPECIFIED.

20170705 13:21 r lawrie

**VOLUME 7 - C.O.E.**  
**DESIGN & CONSTRUCTION**  
**STANDARDS**

REVIEWED BY STANDARDS  
COMMITTEE: 2017-05-26

DRAFTED BY: R. LAWRIE

DESIGNED BY: A. RAHMAN

SCALE: N. T. S.

DATE REVISED: 2017-06-30



**INSTALLATION OF**  
**PRECAST CONCRETE BASE FOR**  
**SINGLE PHASE TRANSFORMERS**

STANDARD NO.

**66 00 07 00 27 115**

PAGE NO.

3 / 7

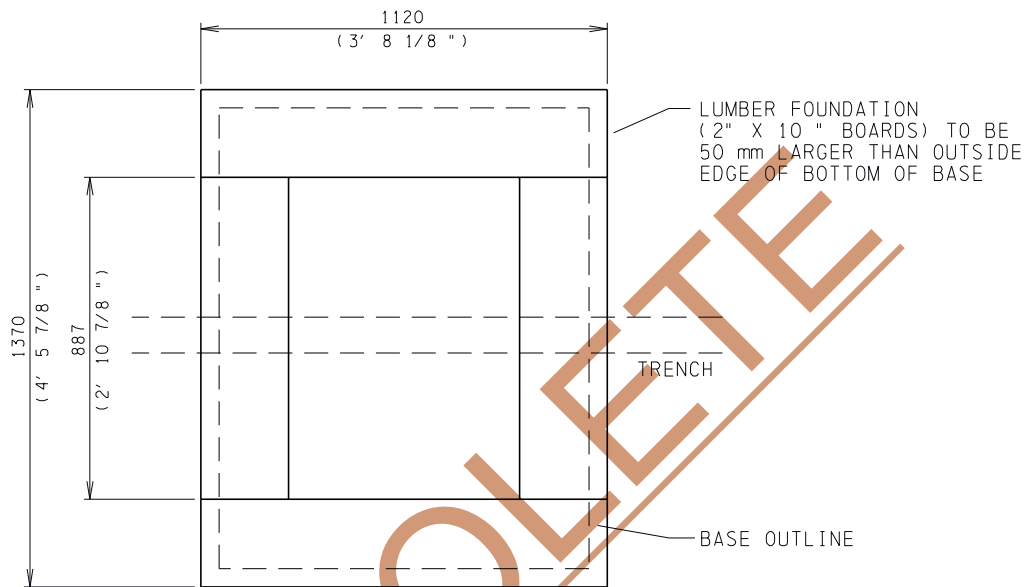

BLVD  
ROAD

LUMBER FOUNDATION  
SCALE: N.T.S.

**NOTES CONT'D:**

21. LUMBER FOUNDATION SHOULD BE 2" x 10" PRESSURE TREATED SPRUCE CUT TO 2 - 1120 mm AND 2 - 887 mm LENGTHS (50 mm MAXIMUM LEDGE ON OUTSIDE)
22. RE-TREAT CUT ENDS OF LUMBER FOUNDATION BOARDS WITH COPPER NAPHTHANATE WOOD PRESERVATIVE.

ALL DIMENSIONS IN MILLIMETERS (INCHES) UNLESS OTHERWISE SPECIFIED.

**VOLUME 7 - C.O.E.  
DESIGN & CONSTRUCTION  
STANDARDS**

REVIEWED BY STANDARDS  
COMMITTEE: 2017-05-26

DRAFTED BY: R. LAWRIE

DESIGNED BY: A. RAHMAN

SCALE: N. T. S.

DATE REVISED: 2017-06-30



**INSTALLATION OF  
PRECAST CONCRETE BASE FOR  
SINGLE PHASE TRANSFORMERS**

STANDARD NO.

**66 00 07 00 27 115**

PAGE NO.

4 / 7

TYPICAL REMOVABLE GUARDRAIL INSTALLATION

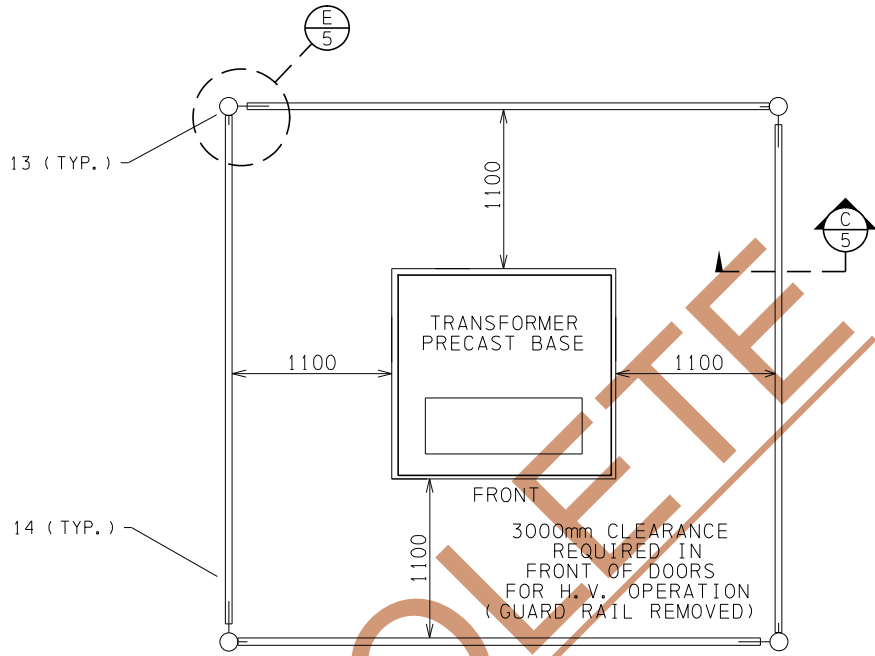

TOP VIEW - TYPICAL REMOVABLE GUARDRAIL CONSTRUCTION  
SCALE: N.T.S.

OBSOLETE

NOTES CONT'D:

- 23. STEEL REMOVABLE GUARDRAILS WITH CONCRETED STEEL BOLLARD POSTS ARE REQUIRED FOR ALL TRANSFORMERS ON PRIVATE PROPERTY.
- 24. FOR ALL TRANSFORMERS ON PUBLIC PROPERTY, MECHANICAL PROTECTION FOR PADMOUNTED EQUIPMENT SHALL BE CONSIDERED AS PER CSA C22.3 No. 7-15 CLAUSE 10.5.
- 25. CONCRETE SHALL BE 25 MPa OR GREATER. ALTERNATE MATERIALS MAY BE ACCEPTABLE.

ALL DIMENSIONS IN MILLIMETERS ( INCHES ) UNLESS OTHERWISE SPECIFIED.

20170705 13:21 r lawrie

<p><b>VOLUME 7 - C.O.E.</b> <b>DESIGN &amp; CONSTRUCTION</b> <b>STANDARDS</b></p>		<p><b>INSTALLATION OF</b> <b>PRECAST CONCRETE BASE FOR</b> <b>SINGLE PHASE TRANSFORMERS</b></p>
<p>REVIEWED BY STANDARDS COMMITTEE: 2017-05-26</p> <p>DRAFTED BY: R. LAWRIE</p> <p>DESIGNED BY: A. RAHMAN</p> <p>SCALE: N. T. S.</p> <p>DATE REVISED: 2017-06-30</p>		<p>STANDARD NO. <b>66 00 07 00 27 115</b></p> <p>PAGE NO. 5 / 7</p>

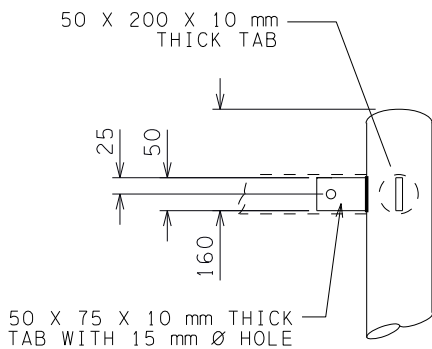

**D** GUARD RAIL DETAIL  
SCALE: N.T.S.

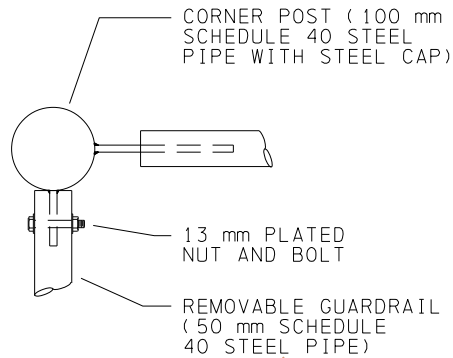

**E** GUARD RAIL DETAIL  
SCALE: N.T.S.

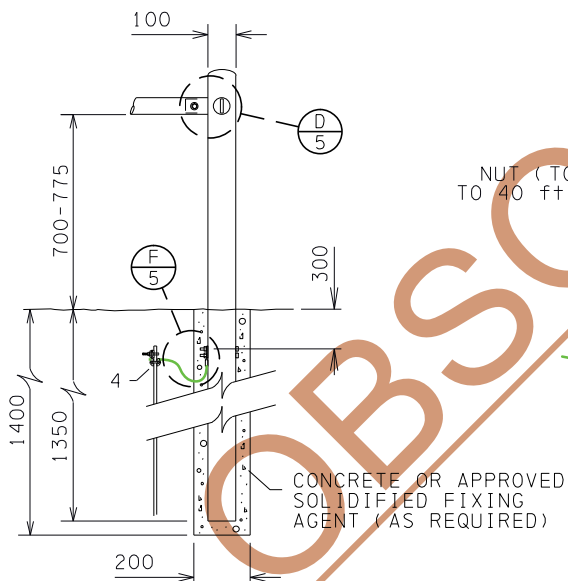

**C** SECTION  
SCALE: N.T.S.

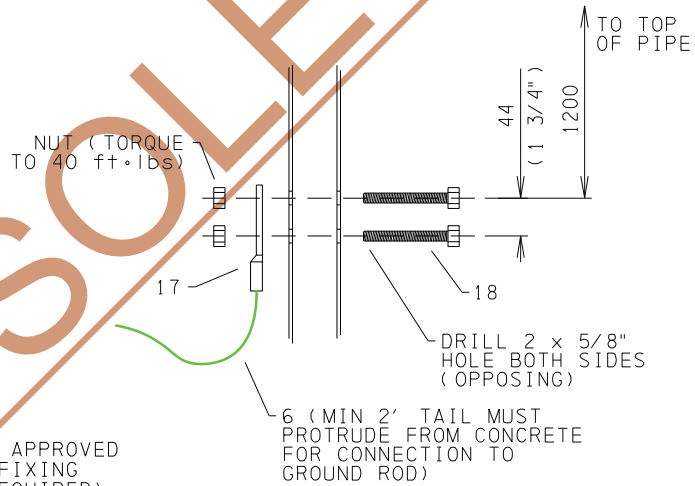

**F** GROUND LUG DETAIL  
SCALE: N.T.S.

ALL DIMENSIONS IN MILLIMETERS (INCHES) UNLESS OTHERWISE SPECIFIED.

**VOLUME 7 - C.O.E.  
DESIGN & CONSTRUCTION  
STANDARDS**

REVIEWED BY STANDARDS  
COMMITTEE: 2017-05-26

DRAFTED BY: R. LAWRIE

DESIGNED BY: A. RAHMAN

SCALE: N. T. S.

DATE REVISED: 2017-06-30



**INSTALLATION OF  
PRECAST CONCRETE BASE FOR  
SINGLE PHASE TRANSFORMERS**

STANDARD NO.

66 00 07 00 27 115

PAGE NO.

6 / 7

ITEM	PART DESCRIPTION	STOCK No.	QTY.
1	BASE PRECAST TRANSFORMER SINGLE PHASE PADMOUNT 1270 x 1020	62891	1
2	ROD GROUNDING 5/8" x 5'	17288	8
3	PIPE DUCT 4"	AS REQ'D	A/R
	DB2 - 4"	53283	
	RIGID PVC - 4"	10083	
4	WIRE #4/0 STRANDED COPPER BARE	45655	A/R
5	LUMBER SPRUCE PRESSURE-TREATED - 2" x 10" x 8' PWF (RE-TREAT CUT ENDS)	13235	2
6	CONNECTOR GROUND 3/4" ROD - 250 1/C	31914	6
7	CONNECTOR GROUND 3/4" - 250 DOUBLE WIRE	9136	2
8	SAND	N/A	A/R
9	ROAD CRUSH - 20 mm	N/A	A/R
10	BEND RIGID PVC	AS REQ'D	A/R
	4" 90 DEGREE 24" RADIUS PLAIN ENDS	44327	
	4" 90 DEGREE 36" RADIUS PLAIN ENDS	22960	
11	END BELL COLLAR - RIGID PVC - 4"	20574	A/R
12	COUPLER - GROUND ROD	17289	4
13	POST CORNER STEEL 4" SCH 40 (C/W BRACKETS & CAP) FOR TRANS. BARRICADES	21835	A/R
14	PIPE STEEL 2" x 14 ft. - SCHEDULE 40	62849	A/R
15	CONCRETE (25 MPa)	N/A	A/R
16	ADAPTER COUPLING 4" DB2 - 4" PVC/FRE	38916	A/R
17	LUG 4/0 COMPRESSION 2 HOLE COPPER	79284	4
18	1/2" x 4" HEX HEAD MACHINE BOLT W/ NUT	N/A	8

OBSOLETE

20170705 13:22 r lawrie

<b>VOLUME 7 - C.O.E. DESIGN &amp; CONSTRUCTION STANDARDS</b>			<b>INSTALLATION OF PRECAST CONCRETE BASE FOR SINGLE PHASE TRANSFORMERS</b>	
REVIEWED BY STANDARDS COMMITTEE: 2017-05-26				
DRAFTED BY: R. LAWRIE				
DESIGNED BY: A. RAHMAN				
SCALE: N. T. S.				
DATE REVISED: 2017-06-30		STANDARD NO. <b>66 00 07 00 27 115</b>	PAGE NO. 7 / 7	

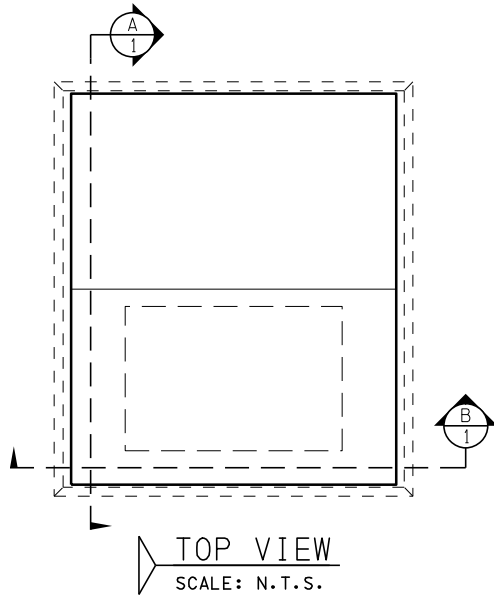

**NOTES:**

1. FOR LOAD BREAK ELBOW, SEE 63 00 07 00 48 006.
2. FOR GROUNDING DETAILS, SEE 65 00 07 00 60 001.
3. FOR ANCHORING DETAILS, SEE 65 00 07 00 23 003.
4. FOR PRIMARY FUSE SELECTION, SEE 60 00 07 15 50 010.
5. ALL CABLES SHALL HAVE A MINIMUM OF 5.0 m OF EXTRA CABLE COILED IN THE BASE MEASURED FROM THE TOP OF PIPE OF BASE ENTRY POINT.
6. FOR RADIAL FEED USE 1 EACH OF ITEMS 2 & 3 AND 1 DEAD END PLUG STOCK No.031795.
7. FOR INSTALLATION OF PRECAST CONCRETE BASE, SEE 66 00 07 00 27 115.

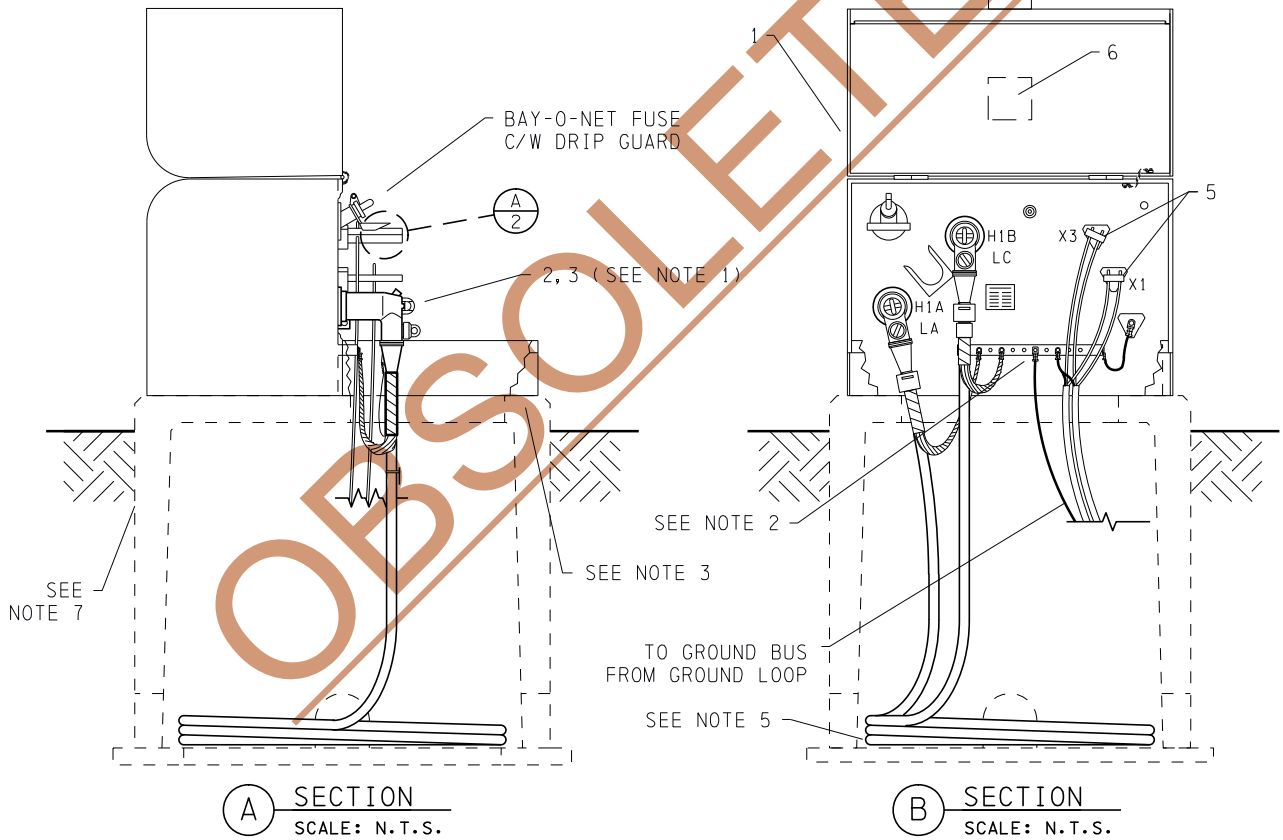

FOR INSTALLATION PURPOSES ONLY -- REFER TO SPECIFICATION DRAWINGS FOR ALL OTHER APPLICATIONS

20170605 12:04 r lawrie

**VOLUME 7 - C.O.E.  
DESIGN & CONSTRUCTION  
STANDARDS**

REVIEWED BY STANDARDS COMMITTEE: 2016-04-12  
 DRAFTED BY: R. LAWRIE  
 DESIGNED BY: A. RAHMAN  
 SCALE: N. T. S.  
 DATE REVISED: 2017-01-06



**INSTALLATION OF SINGLE PHASE  
15 kV MSB TYPE TRANSFORMER**

STANDARD NO.  
**66 00 07 15 27 015**

PAGE NO.  
1 / 3

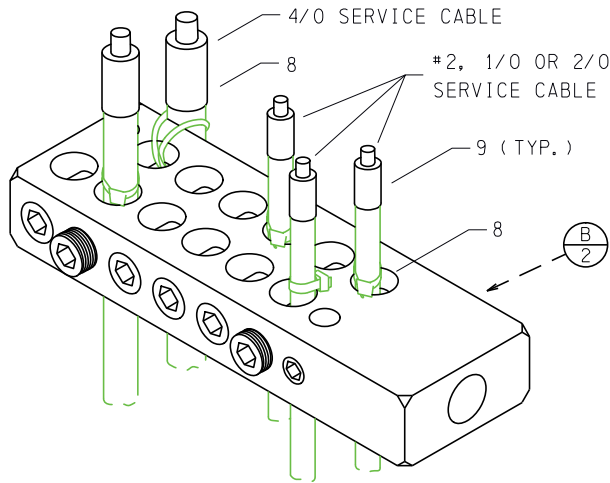

**A** DETAIL  
SCALE: N.T.S.

PRIOR TO SERVICE ENERGIZATION

- URD SERVICING CONTRACTOR TO INSTALL TEMPORARY SERVICE CABLE IDENTIFICATION AS PER THE CITY OF EDMONTON DESIGN AND CONSTRUCTION STANDARDS MANUAL. CLEAR PLASTIC TUBING WITH LEGAL DESCRIPTION IN BLACK PERMANENT INK ON X3 CONDUCTOR.
- SERVICE CABLE #2, 1/0 & 2/0 ARE TO TRAINED INTO THEIR ASSIGNED HOLE. TIE WRAP TO BE INSTALLED AS PER DETAIL. TIGHTEN SET SCREW ONLY TIGHT ENOUGH TO PREVENT CABLE FROM SLIPPING OUT.
- 4/0 SERVICE CABLES TO BE WRAPPED TO OUTSIDE OF TERMINAL BLOCK AS PER DETAIL A.

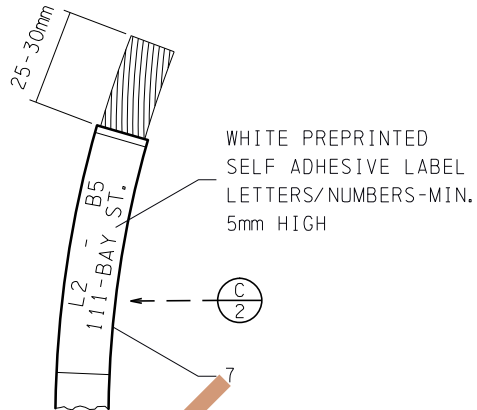

**C** DETAIL  
SCALE: N.T.S.

LABELLING REQUIREMENTS AFTER ENERGIZATION  
(TO BE INSTALLED BY SERVICE ENERGIZER)

NOTE:

1. PERMANENT LABEL GOES ON X3 CONDUCTOR ONLY
2. ADDRESS TO BE INSTALLED AT SERVICE ENERGIZATION TIME.
3. THE PERMANENT LABEL IS TO BE THE STREET ADDRESS.

**TORQUING INSTRUCTIONS:**

CONNECTOR SIZE

SMALL HOLE:

#4 - 2/0 (COMPRESSED)

LARGE HOLE:

#4 - 4/0 (COMPRESSED)

RECOMMENDED TORQUE

SMALL HOLE: 15 - 20 ft lb

LARGE HOLE: 23 - 38 ft lb

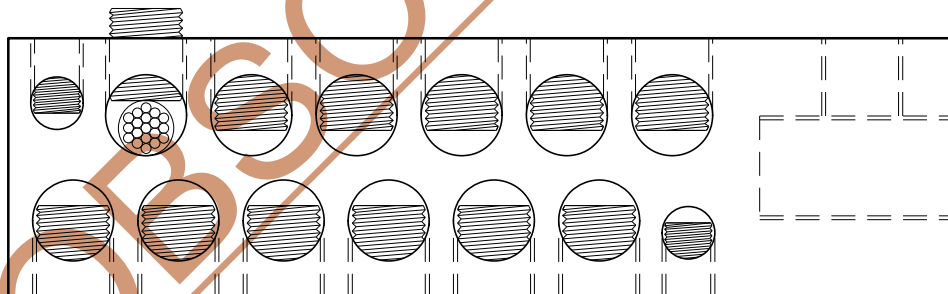

**B** DETAIL - SECONDARY TERMINAL BLOCK  
SEE 66 00 04 03 27 001

**NOTES:**

- a) THE ALLEN WRENCH MUST BE PROPERLY SET IN THE SET SCREW OR DAMAGE WILL BE CAUSED TO THE SET SCREW WHICH WILL "FREEZE" IT IN THE BODY OF THE CONNECTOR.
- b) THE SET SCREW SHOULD BE TORQUED. AFTER A FEW SECONDS THE SET SCREW SHOULD BE RETIGHTENED.
- c) ENSURE THAT THE "ORIENTATION" OF THE TERMINAL BLOCK IS SET, SO THAT THE SET SCREWS CAN BE READILY ACCESSED WHEN CABLES ARE INSTALLED.

**VOLUME 7 - C.O.E.  
DESIGN & CONSTRUCTION  
STANDARDS**

REVIEWED BY STANDARDS  
COMMITTEE: 2016-04-12

DRAFTED BY: R. LAWRIE

DESIGNED BY: A. RAHMAN

SCALE: N. T. S.

DATE REVISED: 2017-01-06



**INSTALLATION OF SINGLE PHASE  
15 KV MSB TYPE TRANSFORMER**

STANDARD NO.

**66 00 07 15 27 015**

PAGE NO.

2 / 3

ITEM	PART DESCRIPTION	STOCK No.	QTY.
1	TRANSFORMER 15 kV SINGLE PHASE	AS REQ'D	1
2	PRIMARY ELBOW AS PER 63 00 07 00 48 006	AS REQ'D	2
3	BUSHING INSERT 15 kV 200 AMP	24592	2
4	PADLOCK SHORT SHACKLE KEYED ALIKE	VMI	1
5	CONNECTOR TRANSFORMER STUD 12 HOLE IN LINE SPADE	57318	2
6	SIGN DANGER TRANSFORMER	65735	1
7	TUBE SHRINK HEAT 1/2" x 9"	62428	A/R
8	TIE WRAPS	VMI	A/R
9	END CAP HEATSHRINK	AS REQ'D	A/R
	END CAP RANGE #6-#2	12301	
	END CAP RANGE #1 - 3/0	12302	

OBSOLETE

20170605 12:05 r lawrie

<b>VOLUME 7 - C.O.E.</b> <b>DESIGN &amp; CONSTRUCTION</b> <b>STANDARDS</b>			<b>INSTALLATION OF SINGLE PHASE</b> <b>15 kV MSB TYPE TRANSFORMER</b>	
REVIEWED BY STANDARDS COMMITTEE: 2016-04-12			STANDARD NO.	PAGE NO.
DRAFTED BY: R. LAWRIE			66 00 07 15 27 015	3 / 3
DESIGNED BY: A. RAHMAN				
SCALE: N. T. S.				
DATE REVISED: 2017-01-06				



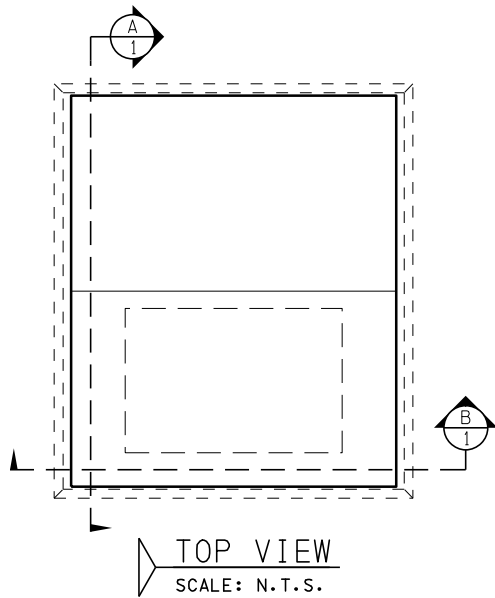

**NOTES:**

1. FOR LOAD BREAK ELBOW, SEE 63 00 07 00 48 006.
2. FOR GROUNDING DETAILS, SEE 65 00 07 00 60 001.
3. FOR ANCHORING DETAILS, SEE 65 00 07 00 23 003.
4. FOR PRIMARY FUSE SELECTION, SEE 60 00 07 25 50 010.
5. ALL CABLES SHALL HAVE A MINIMUM OF 5.0 m OF EXTRA CABLE COILED IN THE BASE MEASURED FROM THE TOP OF PIPE OR BASE ENTRY POINT.
6. FOR RADIAL FEED USE 1 EACH OF ITEMS 2 & 3 AND 1 DEAD END PLUG STOCK No.031795.
7. FOR INSTALLATION OF PRECAST CONCRETE BASE SEE 66 00 07 00 27 115.

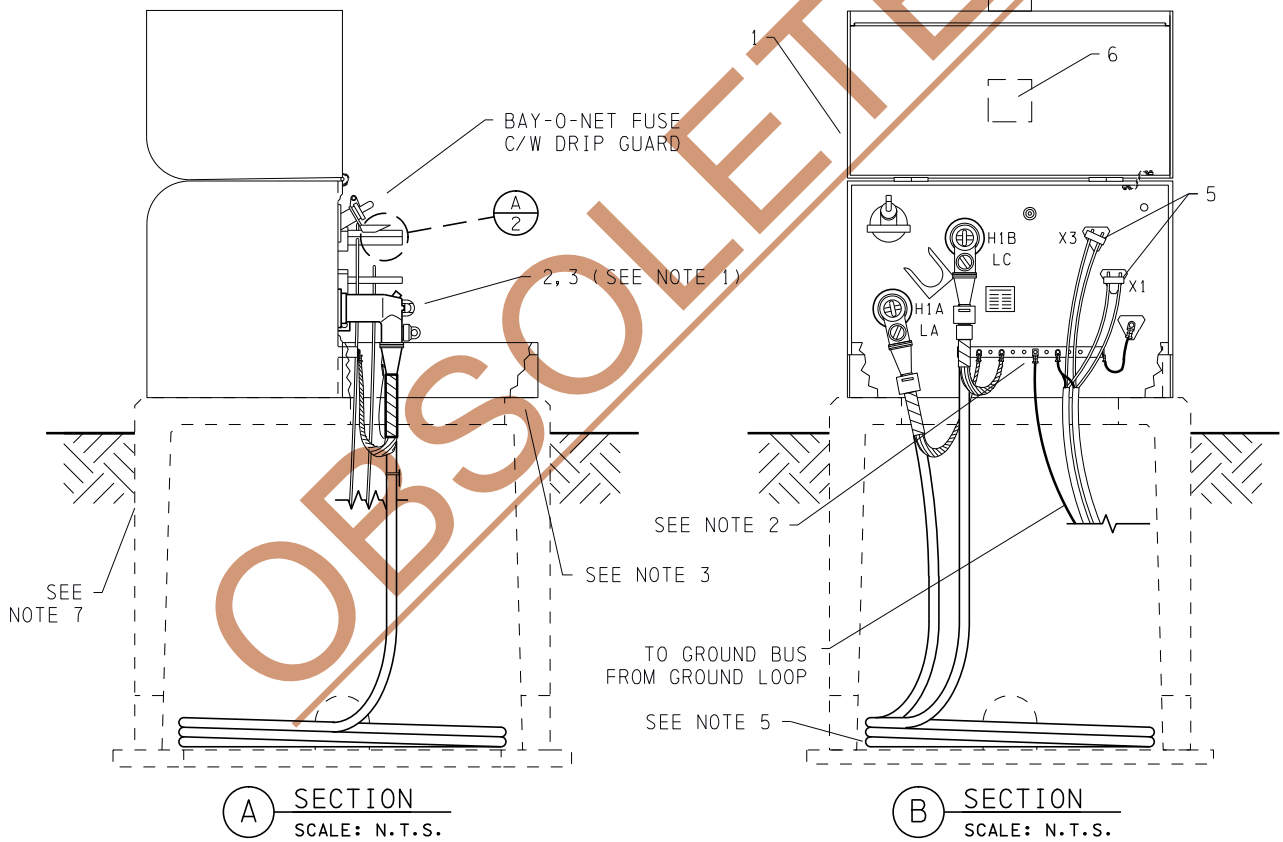

FOR INSTALLATION PURPOSES ONLY -- REFER TO SPECIFICATION DRAWINGS FOR ALL OTHER APPLICATIONS

20170629 16:06 r lawrie

<b>VOLUME 7 - C.O.E. DESIGN &amp; CONSTRUCTION STANDARDS</b>	
REVIEWED BY STANDARDS COMMITTEE:	2016-04-12
DRAFTED BY:	R. LAWRIE
DESIGNED BY:	A. RAHMAN
SCALE:	N. T. S.
DATE REVISED:	2016-05-31



**INSTALLATION OF SINGLE PHASE  
25 kV MNB TYPE TRANSFORMER**

STANDARD NO. <b>66 00 07 25 27 015</b>	PAGE NO. 1 / 3
-------------------------------------------	-------------------

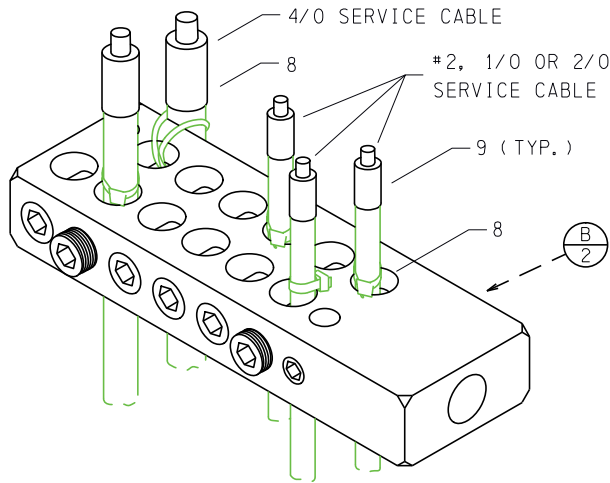

**A** DETAIL  
SCALE: N.T.S.

PRIOR TO SERVICE ENERGIZATION

- URD SERVICING CONTRACTOR TO INSTALL TEMPORARY SERVICE CABLE IDENTIFICATION AS PER THE CITY OF EDMONTON DESIGN AND CONSTRUCTION STANDARDS MANUAL. CLEAR PLASTIC TUBING WITH LEGAL DESCRIPTION IN BLACK PERMANENT INK ON X3 CONDUCTOR.
- SERVICE CABLE #2, 1/0 & 2/0 ARE TO TRAINED INTO THEIR ASSIGNED HOLE. TIE WRAP TO BE INSTALLED AS PER DETAIL. TIGHTEN SET SCREW ONLY TIGHT ENOUGH TO PREVENT CABLE FROM SLIPPING OUT.
- 4/0 SERVICE CABLES TO BE WRAPPED TO OUTSIDE OF TERMINAL BLOCK AS PER DETAIL A.

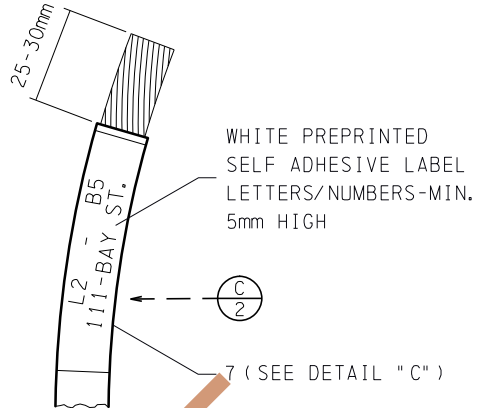

**C** DETAIL  
SCALE: N.T.S.

LABELLING REQUIREMENTS AFTER ENERGIZATION  
(TO BE INSTALLED BY SERVICE ENERGIZER)

NOTE:

1. PERMANENT LABEL GOES ON X3 CONDUCTOR ONLY
2. ADDRESS TO BE INSTALLED AT SERVICE ENERGIZATION TIME.
3. THE PERMANENT LABEL IS TO BE THE STREET ADDRESS.

**TORQUING INSTRUCTIONS:**

CONNECTOR SIZE

SMALL HOLE:

#4 - 2/0 (COMPRESSED)

LARGE HOLE:

#4 - 4/0 (COMPRESSED)

RECOMMENDED TORQUE

SMALL HOLE: 15 - 20 ft lb

LARGE HOLE: 23 - 38 ft lb

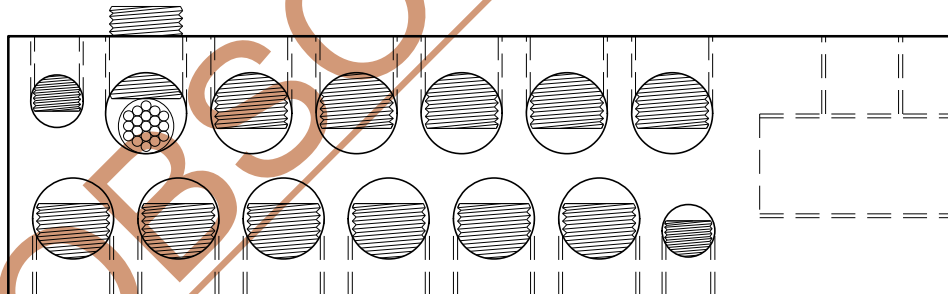

**B** DETAIL - SECONDARY TERMINAL BLOCK  
SEE 66 00 04 03 27 001

**NOTES:**

- a) THE ALLEN WRENCH MUST BE PROPERLY SET IN THE SET SCREW OR DAMAGE WILL BE CAUSED TO THE SET SCREW WHICH WILL "FREEZE" IT IN THE BODY OF THE CONNECTOR.
- b) THE SET SCREW SHOULD BE TORQUED. AFTER A FEW SECONDS THE SET SCREW SHOULD BE RETIGHTENED.
- c) ENSURE THAT THE "ORIENTATION" OF THE TERMINAL BLOCK IS SET, SO THAT THE SET SCREWS CAN BE READILY ACCESSED WHEN CABLES ARE INSTALLED.

**VOLUME 7 - C.O.E.  
DESIGN & CONSTRUCTION  
STANDARDS**

REVIEWED BY STANDARDS  
COMMITTEE: 2016-04-12

DRAFTED BY: R. LAWRIE

DESIGNED BY: A. RAHMAN

SCALE: N. T. S.

DATE REVISED: 2016-05-31



**INSTALLATION OF SINGLE PHASE  
25 KV MNB TYPE TRANSFORMER**

STANDARD NO.

**66 00 07 25 27 015**

PAGE NO.

2 / 3



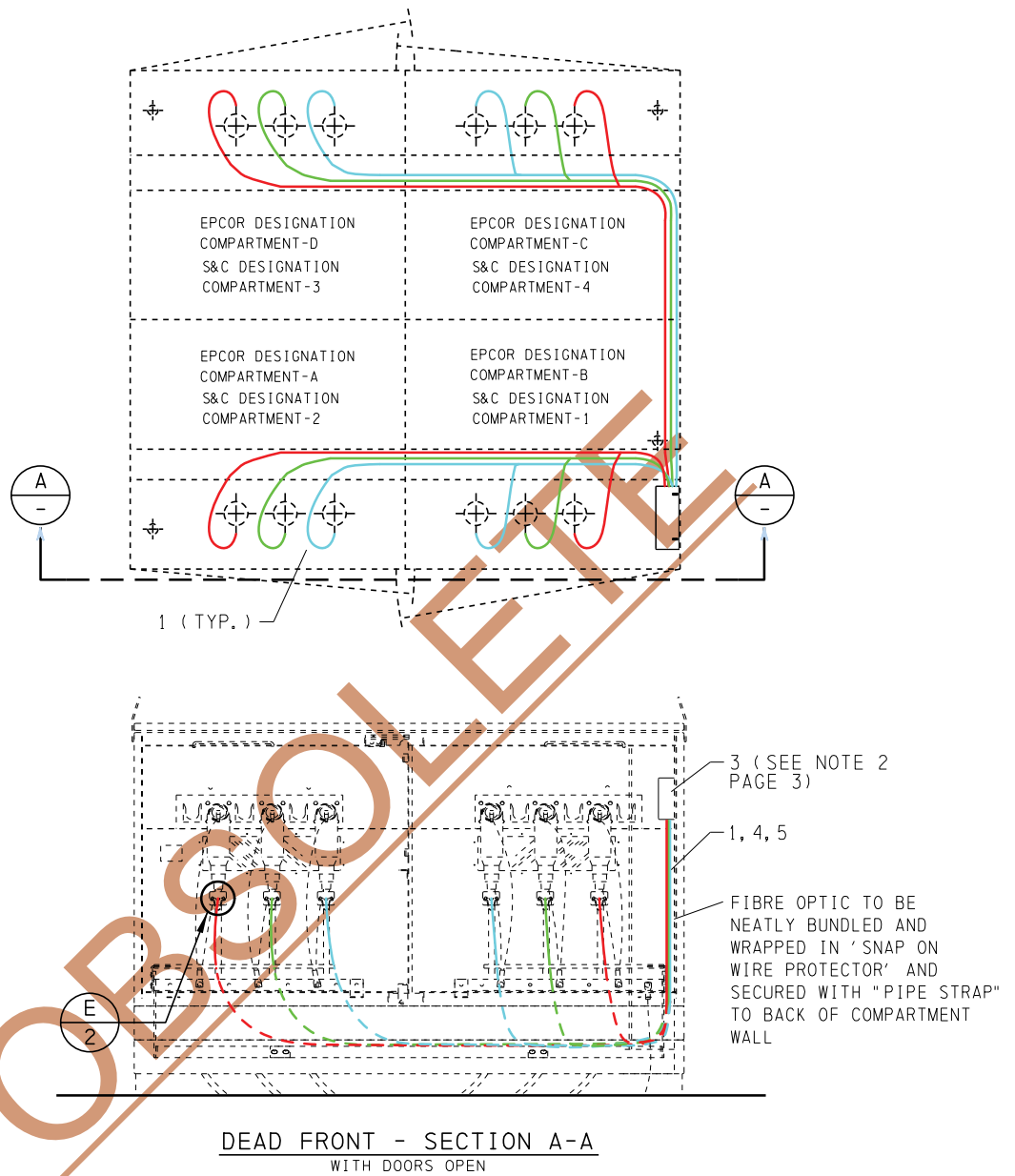

ALL DIMENSIONS ARE IN MILLIMETERS (INCHES) UNLESS OTHERWISE SPECIFIED.

**VOLUME 7 - C.O.E.  
DESIGN & CONSTRUCTION  
STANDARDS**

REVIEWED BY STANDARDS  
COMMITTEE: 2013-08-27  
DRAFTED BY: R. LAWRIE  
DESIGNED BY: A. RAHMAN  
SCALE: N. T. S.  
DATE REVISED: 2016-01-06



**FAULT INDICATOR FIBRE  
OPTIC CABLE INSTALLATION  
ON DEADFRONT SWITCHING  
CUBICLES**

STANDARD NO.  
**63 00 07 00 23 001**

PAGE NO.  
1 / 4

20170601 15:50 r lawrie

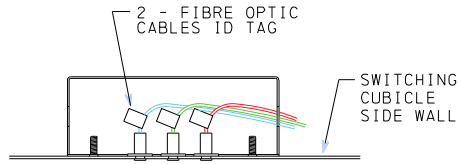

**SECTION C-C**  
TYPICAL F.O. TERMINAL BOX

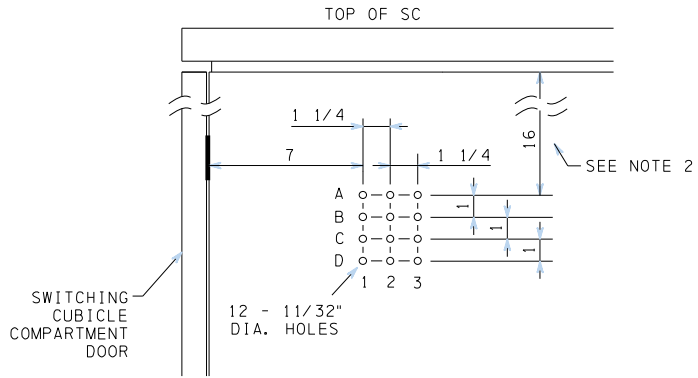

**TYPICAL LED LOCATION**

- ANY UNUSED HOLES TO BE 'BLANKED' USING APPROPRIATELY SIZED CARRIAGE BOLTS

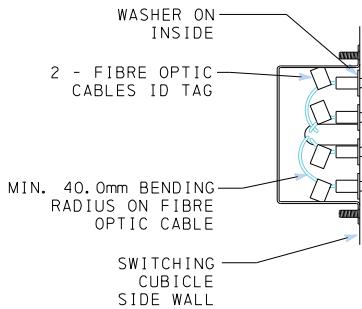

**SECTION D-D**  
TYPICAL F.O. BACKING BOX

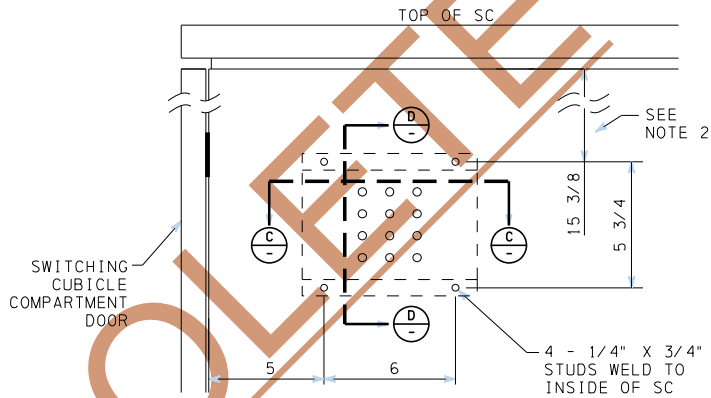

**MOUNTING BOLT/STUD LOCATION**

- ANY UNUSED HOLES TO BE 'BLANKED' USING APPROPRIATELY SIZED CARRIAGE BOLTS

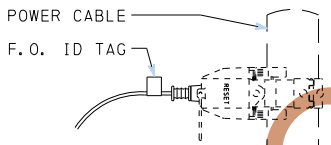

**DETAIL E**  
FOR INSTALLATION OF FAULT CURRENT INDICATOR WITH ELBOW CONNECTION REF.:  
63 00 07 00 48 005 AND  
63 00 07 00 48 006

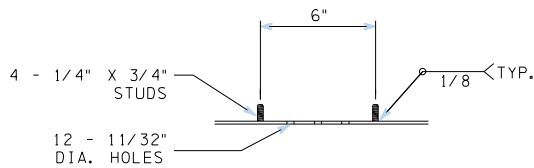

**TYPICAL MOUNTING BOLT/STUD DETAILS FOR F.O. BOX**

ALL DIMENSIONS ARE IN MILLIMETERS (INCHES) UNLESS OTHERWISE SPECIFIED.

**VOLUME 7 - C.O.E.**  
**DESIGN & CONSTRUCTION**  
**STANDARDS**

REVIEWED BY STANDARDS COMMITTEE: 2013-08-27  
DRAFTED BY: R. LAWRIE  
DESIGNED BY: A. RAHMAN  
SCALE: N. T. S.  
DATE REVISED: 2016-01-06



**FAULT INDICATOR FIBRE OPTIC CABLE INSTALLATION ON DEADFRONT SWITCHING CUBICLES**

STANDARD NO.  
**63 00 07 00 23 001**

PAGE NO.  
2 / 4

NOTES:

INSTALLATION OF ENCLOSURE AND FIBRE OPTICS

1. INSTALL ENCLOSURE INTO CUBICLE ACCORDING TO DIMENSIONS STATED ON PAGE 2 OF THIS STANDARD. THE ENCLOSURE SHOULD BE MOUNTED IN THE CUBICLE IN THE "B" COMPARTMENT AND ENSURE CLEAR ACCESS INSIDE CUBICLE.
2. ON PMSG-12 CUBICLES THIS DIMENSION MUST BE INCREASED BY 3 INCHES TO PROVIDE ADEQUATE CLEARANCE IN COMPARTMENT "B".
3. INSTALL 1 FIBRE OPTIC LEAD FROM EACH FAULT INDICATOR (SHAPE TO MAINTAIN CLEARANCES). LEAVE 12" TO 18" OF SLACK IN ENCLOSURE.
4. FIBRE OPTIC CABLE IS TO BE NEATLY BUNDLED AND WRAPPED IN "SNAP ON" WIRE PROTECTOR AND SECURED USING TIE WRAPS AND FLEXIBLE OPEN WIRE WRAP CONDUIT TO COVER THE FIBRE OPTIC CABLE.
5. LED ARE TO BE INSTALLED IN SWITCH COMPARTMENT B.
6. FOR 600 A ELBOW CONNECTION AND FAULT INDICATOR INSTALLATION REFER TO STANDARD 63 00 07 00 48 005 OR 63 00 07 15 48 005. FOR 200 A ELBOW CONNECTION AND FAULT INDICATOR INSTALLATION REFER TO STANDARD 63 00 07 00 48 006.
7. POSITIVELY IDENTIFY THE FIBRE OPTIC LEADS IN THE ENCLOSURE AND INSTALL HEAT SHRINK LABELS WITH COMPARTMENT AND PHASE IDENTIFICATION; COIL INTO ENCLOSURE AND TERMINATE.

OBSOLETE

VOLUME 7 - C.O.E.  
DESIGN & CONSTRUCTION  
STANDARDS

REVIEWED BY STANDARDS  
COMMITTEE: 2013-08-27

DRAFTED BY: R. LAWRIE

DESIGNED BY: A. RAHMAN

SCALE: N. T. S.

DATE REVISED: 2016-01-06



FAULT INDICATOR FIBRE  
OPTIC CABLE INSTALLATION  
ON DEADFRONT SWITCHING  
CUBICLES

STANDARD NO.  
63 00 07 00 23 001

PAGE NO.  
3 / 4

20170601 15:44 r lawrie

ITEM	PART DESCRIPTION	STOCK No.	QTY.
1	CABLE FIBRE OPTIC ASSEMBLY 10ft. 15ft. 20ft.	AS REQ'D 68610 64615 56408	12
2	LABEL WIRE MARKER	11888	24
3	ENCLOSURE ELECTRONICS - FIBRE OPTIC	20508	1
4	STRAP PIPE, 1 INCH, 1HOLE	46740	A/R
5	FIBRE OPTIC CABLE PROTECTOR COVER (FLEXIBLE)	VMI	A/R

OBSOLETE

<p><b>VOLUME 7 - C.O.E.</b> <b>DESIGN &amp; CONSTRUCTION STANDARDS</b></p>		<b>FAULT INDICATOR FIBRE OPTIC CABLE INSTALLATION ON DEADFRONT SWITCHING CUBICLES</b>				
				REVIEWED BY STANDARDS COMMITTEE: 2013-08-27	STANDARD NO. <b>63 00 07 00 23 001</b>	PAGE NO. 4 / 4
				DRAFTED BY: R. LAWRIE		
				DESIGNED BY: A. RAHMAN		
SCALE: N. T. S.	DATE REVISED: 2016-01-06					

20170601 15:47 rlawrie

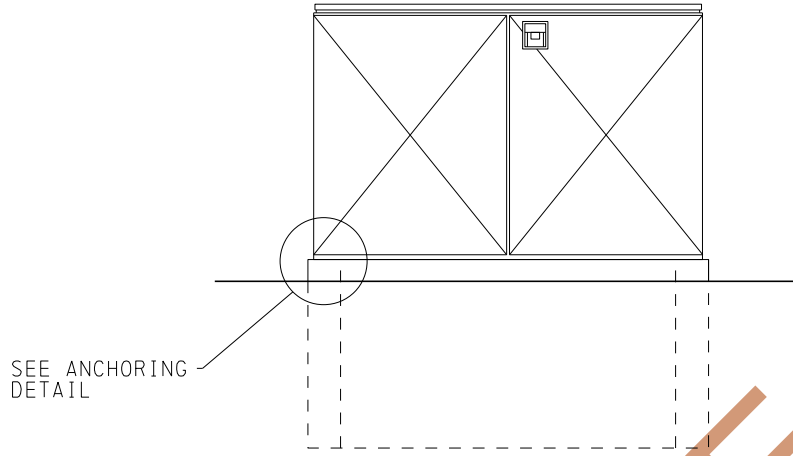

SWITCHING CUBICLE

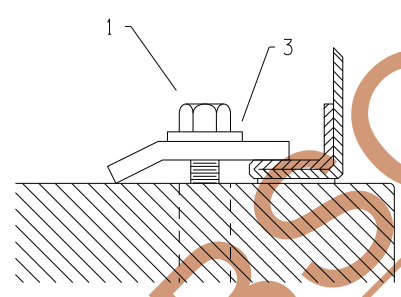

ANCHORING DETAIL  
(TYPICAL FRONT)

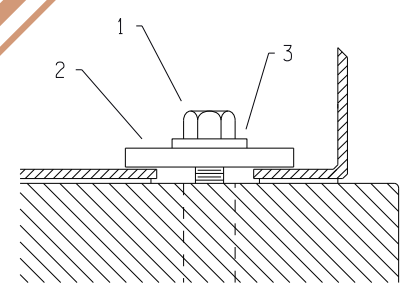

ANCHORING DETAIL  
(TYPICAL REAR)

**NOTE:**

ANGLE PLATES ARE INCLUDED WITH SWITCHING CUBICLE ASSEMBLY. IF PLATE IS NOT PRESENT USE FLAT PLATE (ITEM 2).

20170602 10:40 r lawrie

<b>VOLUME 7 - C.O.E. DESIGN &amp; CONSTRUCTION STANDARDS</b>	
REVIEWED BY STANDARDS COMMITTEE:	2014-07-08
DRAFTED BY:	R. LAWRIE
DESIGNED BY:	A. RAHMAN
SCALE:	N. T. S.
DATE REVISED:	2014-07-16



**SWITCHING CUBICLE  
ANCHORING DETAIL**

STANDARD NO. <b>65 00 07 00 23 003</b>	PAGE NO. 1 / 2
-------------------------------------------	-------------------



ITEM	PART DESCRIPTION	STOCK No.	QTY.
1	BOLT STEEL HEX CAP 5/8" x 1" NC PLATED	VMI	4
2	PLATE MINI-PAD 6" x 2" x 1/4" 3/4" HOLE GALVANIZED	73145	4
3	WASHER FLAT 1" ROUND - 5/8" BOLT SIZE	48276	4

OBSOLETE

20170602 10:44 r lawrie

<b>VOLUME 7 - C.O.E. DESIGN &amp; CONSTRUCTION STANDARDS</b>			<b>SWITCHING CUBICLE ANCHORING DETAIL</b>			
REVIEWED BY STANDARDS COMMITTEE: 2014-07-08			STANDARD NO. <b>65 00 07 00 23 003</b>			
DRAFTED BY: R. LAWRIE					PAGE NO. <b>2 / 2</b>	
DESIGNED BY: A. RAHMAN						
SCALE: N. T. S.						
DATE REVISED: 2014-07-16						

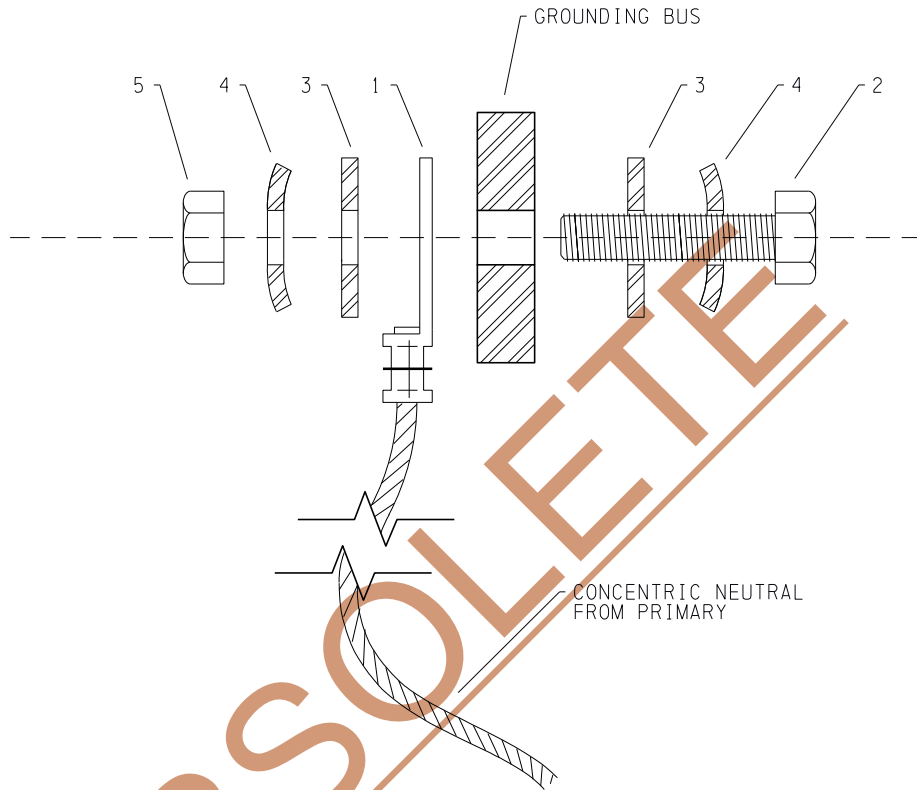

**NOTES:**

1. PRIMARY & SECONDARY CABLE CONCENTRIC NEUTRAL GROUND LUG SHALL BE AS PER TABLE ON PAGE 2.
2. SILICON BRONZE BOLTS TO BE TIGHTENED TO 20 ft·lbs TORQUE.
3. MATERIAL LIST IS FOR ONE GROUND BUS CABLE TERMINATION ONLY.
4. FOR 4/0 BARE COPPER GROUND GRIDS BOTH GROUND TAILS SHALL BE CONNECTED (FRONT TO BACK) IN THE B COMPARTMENT OF SWITCHING CUBICLES OR BETWEEN THE PRIMARY AND SECONDARY CONNECTION OF TRANSFORMERS.

20170602 10:54 r lawrie

**VOLUME 7 - C.O.E.  
DESIGN & CONSTRUCTION  
STANDARDS**

REVIEWED BY STANDARDS  
COMMITTEE: 2017-05-26

DRAFTED BY: R. LAWRIE

DESIGNED BY: A. RAHMAN

SCALE: N. T. S.

DATE REVISED: 2017-05-04



**GROUNDING CONNECTION DETAILS  
FOR SWITCHING CUBICLES &  
TRANSFORMERS**

STANDARD NO.  
**65 00 07 00 60 001**

PAGE NO.  
1 / 3

## TABLE FOR LUGS SELECTION

### TABLE 1 - LUGS FOR CONCENTRIC NEUTRAL GROUNDING CONNECTION OF PRIMARY CABLES

CABLE STOCK NUMBER	PRIMARY CABLE SIZE	LUG SIZE FOR NEUTRAL	LUG STOCK NUMBER
46339	1/0 AL 15 KV CN CABLE	#2 - 3/8" HOLE	172
4934	1/0 AL 25 KV CN CABLE	#2 - 3/8" HOLE	172
15175	2/0 CU 15 KV CN CABLE	#2 - 3/8" HOLE	172
32501 & 14621	500 MCM CU 15 KV CN CABLE	#2/0 - 3/8" HOLE	38489
69903	500 MCM AL 25 KV CN CABLE	#1/0 - 3/8" HOLE	43500
17197	750 MCM CU 15 KV FN CABLE	#4/0 - 3/8" HOLE	44950
10194	750 MCM CU 15 KV CN CABLE	#4/0 - 3/8" HOLE	44950
11297	750 MCM CU 15 KV LC SHIELD CABLE - LIVEFRONT	#4/0 - 3/8" HOLE	44950
11297	750 MCM CU 15 KV LC SHIELD CABLE - ELBOW	#2 - 3/8" HOLE	172
13148 & 13158	750 MCM CU 28 KV CN CABLE	#4/0 - 3/8" HOLE	44950

### TABLE 2 - LUGS FOR CONCENTRIC NEUTRAL GROUNDING CONNECTION OF SECONDARY CABLES

CABLE STOCK NUMBER	SECONDARY CABLE SIZE	LUG SIZE FOR NEUTRAL	LUG STOCK NUMBER
30216	#4 AL JCN USEB90 CABLE	#6 - 3/8" HOLE	31771
22532	#2 AL JCN USEB90 CABLE	#4 - 3/8" HOLE	53081
80898	#1/0 AL JCN USEB90 CABLE	#2 - 3/8" HOLE	172
51879	#2/0 AL JCN USEB90 CABLE	#1/0 - 3/8" HOLE	43500
80902	#4/0 AL JCN USEB90 CABLE	#2/0 - 3/8" HOLE	38489

### TABLE 3 - LUGS FOR GROUNDING CONDUCTOR CONNECTION

CABLE STOCK NUMBER	GROUNDING CABLE SIZE	LUG SIZE FOR NEUTRAL	LUG STOCK NUMBER
45655	* 4/0 BARE CU CABLE	#4/0 - 3/8" HOLE	44950

\* - GROUND GRIDS REQUIRE 2 LUGS.

**VOLUME 7 - C.O.E.  
DESIGN & CONSTRUCTION  
STANDARDS**

REVIEWED BY STANDARDS  
COMMITTEE: 2017-05-26

DRAFTED BY: R. LAWRIE

DESIGNED BY: A. RAHMAN

SCALE: N. T. S.

DATE REVISED: 2017-05-04



**GROUNDING CONNECTION DETAILS  
FOR SWITCHING CUBICLES &  
TRANSFORMERS**

STANDARD NO.

**65 00 07 00 60 001**

PAGE NO.

2 / 3



## DEADFRONT 15 kV 600 A 4-WAY SWITCHING CUBICLES

15T462DD  
2 LB & 2 FDS

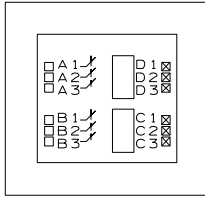

STK# 44611  
( PMSG-9)

15T464DD  
4 LB

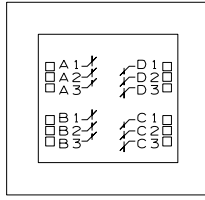

STK# 72699  
( PMSG-10)

15T463DD  
3 LB & 1 FDS

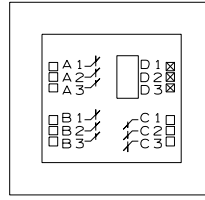

STK# 30281  
( PMSG-11)

15T461DD  
1 LB & 3 FDS

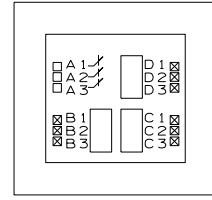

STK# 41632  
( PMSG-12)

1. FOR SWITCHING CUBICLE INSTALLATION SEE STANDARD 65 00 07 15 23 032.
2. FOR PRE-CAST BASE INSTALLATION SEE STANDARD 65 00 07 15 23 132.

## DEADFRONT 15 kV 600 A HEAVY-DUTY 4-WAY SWITCHING CUBICLES

15T462HDD  
2 LB & 2 FDS

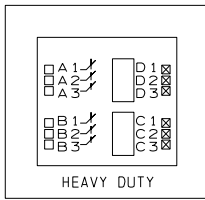

STK# 11255  
( PMSG-9)

STANDARD DUTY  
15 kV 600 A PMSG-10  
CUBICLES ARE RATED AT  
25 kA INTERRUPTING

15T463HDD  
3 LB & 1 FDS

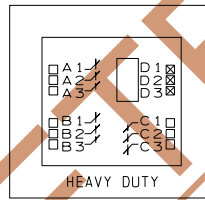

STK# 11275  
( PMSG-11)

15T461HDD  
1 LB & 3 FDS

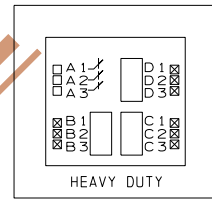

STK# 11299  
( PMSG-12)

1. FOR SWITCHING CUBICLE INSTALLATION SEE STANDARD 65 00 07 15 23 031.
2. FOR PRE-CAST BASE INSTALLATION SEE STANDARD 65 00 07 15 23 132.

## DEADFRONT 15 kV 200 A THREE PHASE 4-WAY

15T422DD  
PMSG-200-9

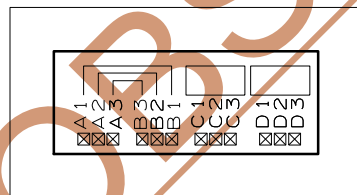

200 AMP DEADFRONT  
STOCK No. 45777

15T421DD  
PMSG-200-12

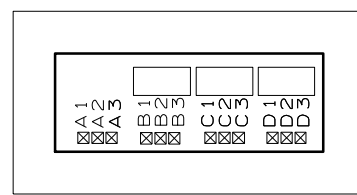

200 AMP DEADFRONT  
STOCK No. 33243

1. FOR SWITCHING CUBICLE INSTALLATION SEE STANDARD 66 00 07 15 23 035.
2. FOR PRE-CAST BASE INSTALLATION SEE STANDARD 65 00 07 15 23 132.
3. THE FAULT RATING OF THIS CUBICLE IS LIMITED BY THE RATING OF THE 200A ELBOW - 200A CONTINUOUS, 10kA SYMMETRICAL, 10 CYCLES.

VOLUME 7 - C.O.E.  
DESIGN & CONSTRUCTION  
STANDARDS

REVIEWED BY STANDARDS  
COMMITTEE: 2014-04-08

DRAFTED BY: R. LAWRIE

DESIGNED BY: A. RAHMAN

SCALE: N. T. S.

DATE REVISED: 2017-01-06



SUMMARY OF 15 kV  
DEAD FRONT SWITCHING CUBICLE  
SCHEMATIC INFORMATION

STANDARD NO.  
65 00 07 15 23 009

PAGE NO.  
1 / 2

DEADFRONT 15 kV 200 A SINGLE PHASE 4-WAY

8S422DD  
PMSG-SF4

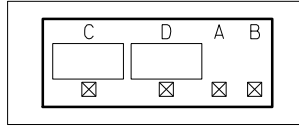

200 AMP DEADFRONT  
STOCK No. 44215

1. FOR SWITCHING CUBICLE INSTALLATION SEE STANDARD 66 00 07 15 23 014.
3. FOR PRE-CAST BASE INSTALLATION SEE STANDARD 66 00 07 15 23 114.

**OBSOLETE**

VOLUME 7 - C.O.E.  
DESIGN & CONSTRUCTION  
STANDARDS

REVIEWED BY STANDARDS  
COMMITTEE: 2014-04-08

DRAFTED BY: R. LAWRIE

DESIGNED BY: A. RAHMAN

SCALE: N. T. S.

DATE REVISED: 2017-01-06



SUMMARY OF 15 kV  
DEAD FRONT SWITCHING CUBICLE  
SCHEMATIC INFORMATION

STANDARD NO.

65 00 07 15 23 009

PAGE NO.

2 / 2

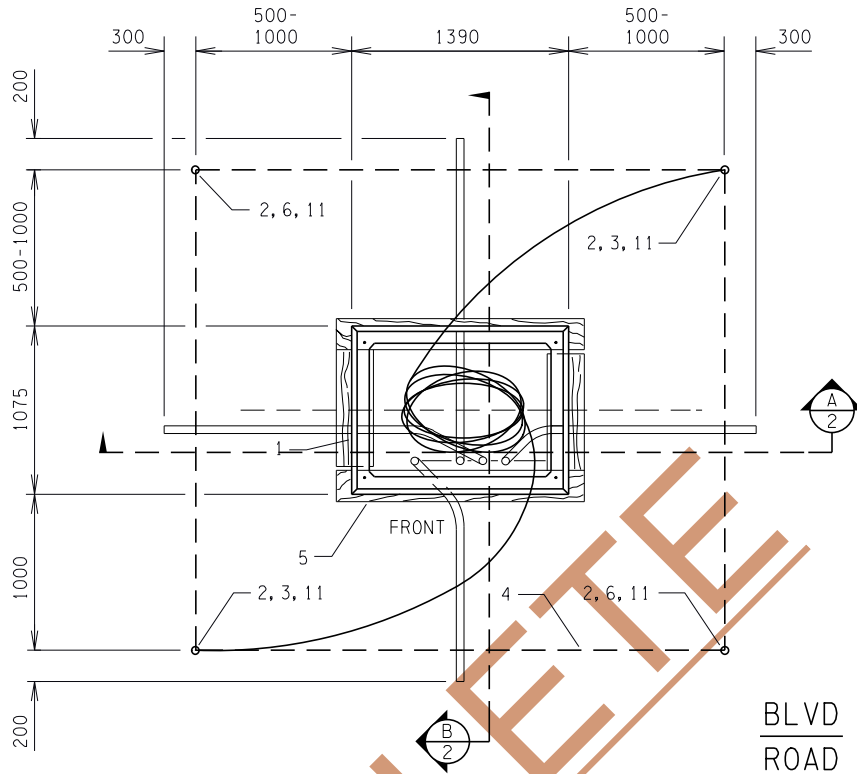

PLAN VIEW  
SCALE: N.T.S.

**NOTES:**

1. INTERCONNECTING GRADIENT CONTROL CONDUCTORS SHALL BE INSTALLED A MINIMUM OF 300 mm BELOW FINAL FINISHED GRADE (NOT ROUGH GRADE) WITH ONE LEG CONTINUOUS AROUND THE PERIMETER AND INTO THE BASE WITH AN ADDITIONAL CONTINUOUS CONDUCTOR TAIL ATTACHED FROM THE OPPOSITE CORNER.
2. USE FINE FILL CLAY BACKFILL AROUND GROUND GRID.
3. OBSERVE 250 mm MINIMUM AND 300 mm MAXIMUM REQUIREMENT FOR ELEVATION FROM TOP OF BASE TO FINAL FINISHED GRADE (NOT ROUGH GRADE).
4. CABLES ARE TO BE INSTALLED THROUGH DUCTS ONLY.
5. RETAIN 5.0 m OF COILED 4/0 CU FOR CONNECTION TO GROUND BUS.
6. THE DUCTING SHOULD BE INSTALLED SO THAT THE ENDS ARE POINTING DIRECTLY UPWARDS WITH THE TOP OF THE END BELL 200 mm ABOVE THE PLANKS/BASE BOTTOM. SPARE DUCTS TO BE CAPPED AND TAPED.
7. ADDITIONAL GROUND ROD MAY BE REQUIRED TO ACHIEVE A RESISTANCE OF 6 OHMS OR LESS.
8. FOR CABLE BYPASS TROUGH REQUIREMENTS AND INSTALLATION SEE DRAWING 66 00 07 00 46 005.
9. ALL CABLES SHALL HAVE A MINIMUM OF 5 m OF EXTRA CABLE COILED IN THE BASE MEASURED FROM THE TOP OF PIPE OR THE BASE ENTRY POINT.
10. MECHANICAL PROTECTION FOR PADMOUNTED EQUIPMENT SHALL BE CONSIDERED AS PER CSA C22.3 No. 7-15 CLAUSE 10.5.
11. THE BASE SHALL BE INSTALLED SUCH THAT THE TOP SURFACE IS LEVEL.
12. BASE WEIGHT: 1175 kg (2590 lbs).

ALL DIMENSIONS IN MILLIMETERS ( INCHES) UNLESS OTHERWISE SPECIFIED.

20170705 13:31 r lawrie

<b>VOLUME 7 - C.O.E.</b> <b>DESIGN &amp; CONSTRUCTION</b> <b>STANDARDS</b>		<b>INSTALLATION OF PRECAST</b> <b>CONCRETE BASE FOR 4-WAY</b> <b>15 kV SINGLE PHASE 200 AMP</b> <b>DEADFRONT SWITCHING CUBICLE</b>	
REVIEWED BY STANDARDS COMMITTEE: 2017-05-26		STANDARD NO.	PAGE NO.
DRAFTED BY: R. LAWRIE		<b>66 00 07 15 23 114</b>	1 / 5
DESIGNED BY: A. RAHMAN			
SCALE: N. T. S. DATE REVISED: 2017-06-30			

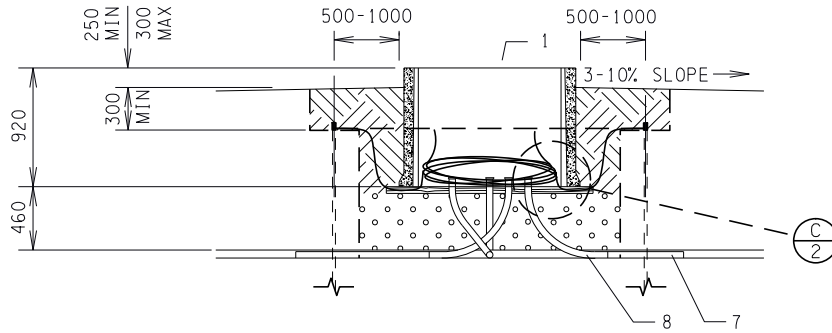

**(A) SECTION**  
SCALE: N.T.S.

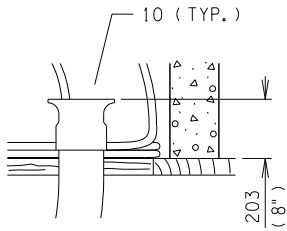

**(C) DETAIL**  
SCALE: N.T.S.

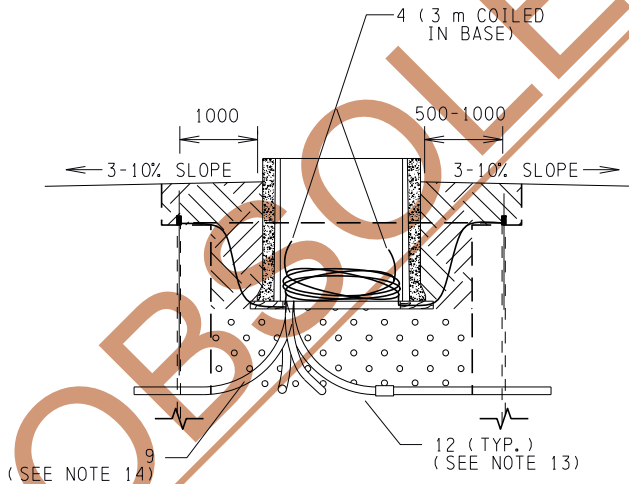

**(B) SECTION**  
SCALE: N.T.S.

**NOTES CONT'D:**

- 13. ADAPTER COUPLING IS REQUIRED FOR DB2 CONDUIT.
- 14. 36" RADIUS BENDS ARE PREFERRED FOR ALL DUCT BENDS.

ALL DIMENSIONS IN MILLIMETERS (INCHES) UNLESS OTHERWISE SPECIFIED.

**VOLUME 7 - C.O.E.  
DESIGN & CONSTRUCTION  
STANDARDS**

REVIEWED BY STANDARDS  
COMMITTEE: 2017-05-26  
DRAFTED BY: R. LAWRIE  
DESIGNED BY: A. RAHMAN  
SCALE: N. T. S.  
DATE REVISED: 2017-06-30



**INSTALLATION OF PRECAST  
CONCRETE BASE FOR 4-WAY  
15 kV SINGLE PHASE 200 AMP  
DEADFRONT SWITCHING CUBICLE**

STANDARD NO.  
**66 00 07 15 23 114**

PAGE NO.  
2 / 5



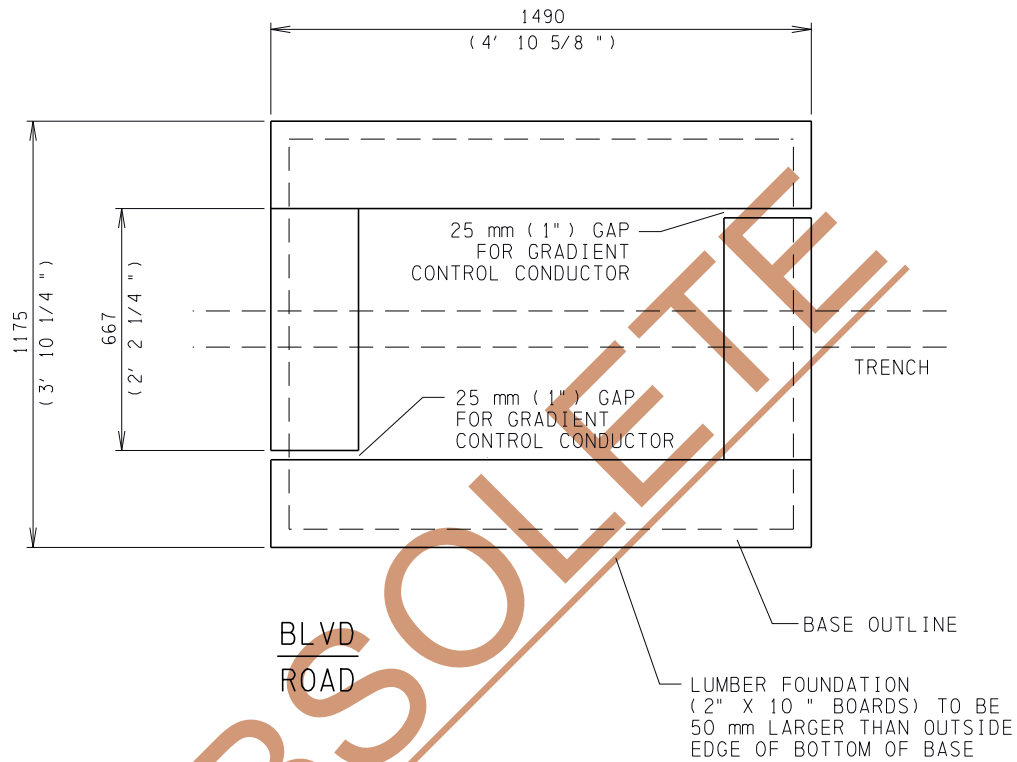

LUMBER FOUNDATION  
SCALE: N.T.S.

NOTES CONT'D:

15. LUMBER FOUNDATION TO BE 2" x 10" PRESSURE TREATED SPRUCE WITH 2 - 1490 mm AND 2 - 667 mm LENGTHS (50 mm MAXIMUM LEDGE ON OUTSIDE).
16. RE-TREAT CUT ENDS OF LUMBER FOUNDATION BOARDS WITH COPPER NAPHTHANATE WOOD PRESERVATIVE.

ALL DIMENSIONS IN MILLIMETERS ( INCHES ) UNLESS OTHERWISE SPECIFIED.

**VOLUME 7 - C.O.E.  
DESIGN & CONSTRUCTION  
STANDARDS**

REVIEWED BY STANDARDS  
COMMITTEE: 2017-05-26

DRAFTED BY: R. LAWRIE

DESIGNED BY: A. RAHMAN

SCALE: N. T. S.

DATE REVISED: 2017-06-30



**INSTALLATION OF PRECAST  
CONCRETE BASE FOR 4-WAY  
15 kV SINGLE PHASE 200 AMP  
DEADFRONT SWITCHING CUBICLE**

STANDARD NO.

**66 00 07 15 23 114**

PAGE NO.

3 / 5

20170705 13:32 r lawrie

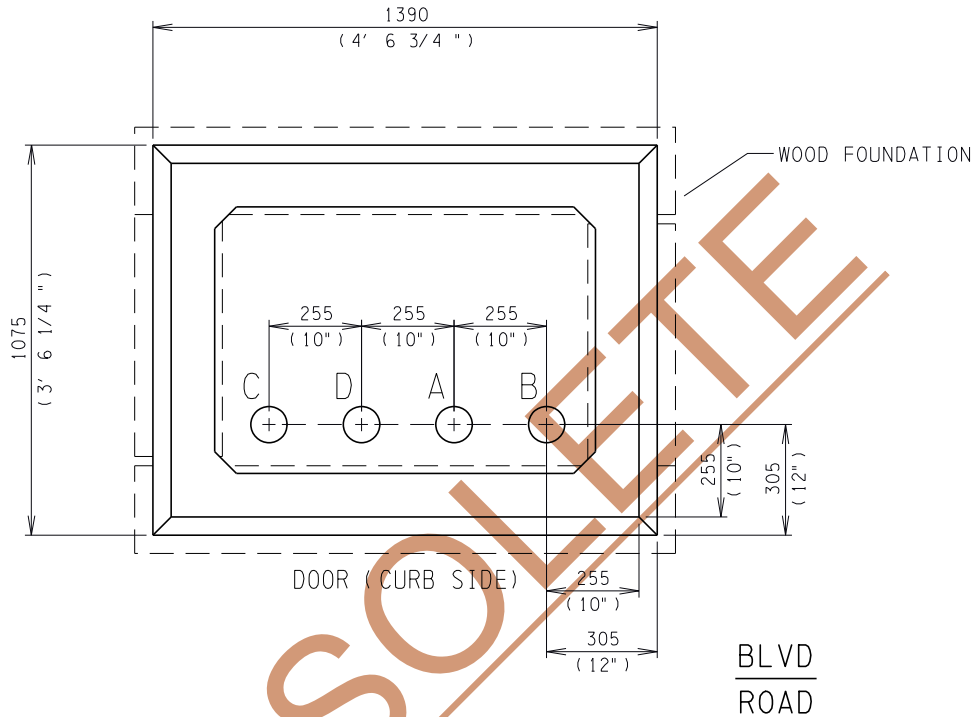

PIPE LOCATIONS  
SCALE: N.T.S.

NOTES CONT'D:

17. ALL PIPES SHOULD BE DB2 OR RIGID PVC, BENDS TO BE RIGID PVC.
18. DUCT SIZES AS PER STANDARD 63 00 07 00 37 001.
19. ALL MEASUREMENTS ARE TO THE OUTSIDE "TOP" OF THE BASE.

ALL DIMENSIONS IN MILLIMETERS (INCHES) UNLESS OTHERWISE SPECIFIED.

VOLUME 7 - C.O.E.  
DESIGN & CONSTRUCTION  
STANDARDS

REVIEWED BY STANDARDS  
COMMITTEE: 2017-05-26

DRAFTED BY: R. LAWRIE

DESIGNED BY: A. RAHMAN

SCALE: N. T. S.

DATE REVISED: 2017-06-30



INSTALLATION OF PRECAST  
CONCRETE BASE FOR 4-WAY  
15 kV SINGLE PHASE 200 AMP  
DEADFRONT SWITCHING CUBICLE

STANDARD NO.

66 00 07 15 23 114

PAGE NO.

4 / 5

ITEM	PART DESCRIPTION	STOCK No.	QTY.
1	BASE PRECAST 200 AMP 15 kV 4-WAY 1 PHASE DEADFRONT SWITCHING CUBICLE	61415	1
2	ROD GROUNDING 5/8" x 5'	17288	8
3	CONNECTOR GROUND ROD 3/4" - 250 DOUBLE WIRE	9136	2
4	WIRE #4/0 STRANDED COPPER BARE	45655	35
5	LUMBER SPRUCE PRESSURE-TREATED - 2" x 10" x 8' PWF (RE-TREAT CUT ENDS)	13235	2
6	CONNECTOR GROUND 3/4" ROD - 250 1/C	31914	2
7	PIPE DUCT 4"	AS REQ'D	A/R
	DB2 - 4"	53283	
	RIGID PVC - 4"	10083	
8	ROAD CRUSH - 3/4"	N/A	A/R
9	BEND RIGID PVC	AS REQ'D	A/R
	4" 90 DEGREE 24" RADIUS PLAIN ENDS	44327	
	4" 90 DEGREE 36" RADIUS PLAIN ENDS	22960	
10	END BELL COLLAR - RIGID PVC - 4"	20574	A/R
11	COUPLER - GROUND ROD	17289	4
12	ADAPTER COUPLING 4" DB2 - 4" PVC/FRE	38916	A/R

OBSOLETE

20170705 13:33 r lawrie

**VOLUME 7 - C.O.E.  
DESIGN & CONSTRUCTION  
STANDARDS**

REVIEWED BY STANDARDS  
COMMITTEE: 2017-05-26

DRAFTED BY: R. LAWRIE

DESIGNED BY: A. RAHMAN

SCALE: N. T. S.

DATE REVISED: 2017-06-30



**INSTALLATION OF PRECAST  
CONCRETE BASE FOR 4-WAY  
15 kV SINGLE PHASE 200 AMP  
DEADFRONT SWITCHING CUBICLE**

STANDARD NO. <b>66 00 07 15 23 114</b>	PAGE NO. 5 / 5
-------------------------------------------	-------------------

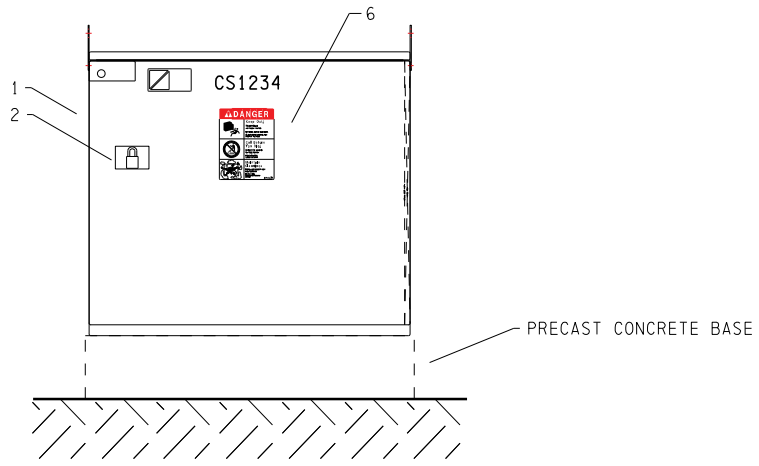

FRONT VIEW

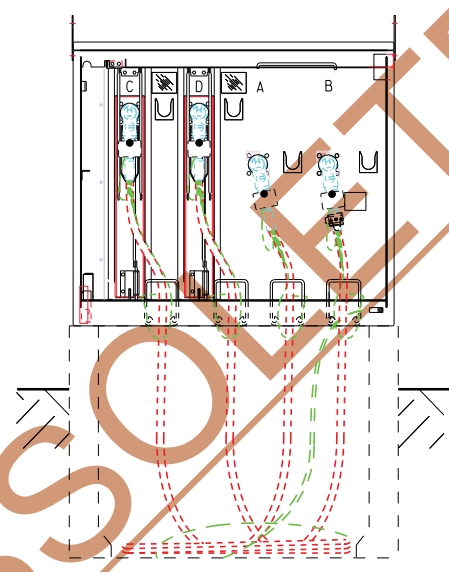

8S422DD\*\*\* (PMSG-SF4)  
FEED THROUGH & FUSE COMPARTMENT (C, D, A & B)

**NOTES:**

1. GROUNDING CONNECTION AND DETAILS SHOULD BE AS PER STANDARD 65 00 07 00 60 001.
2. PHYSICAL LOCATION OF FUSES ARE AS PER SCHEMATICS (SEE PAGE 2).
3. LOAD BREAK ELBOWS ARE TERMINATED AS PER STANDARD 63 00 07 00 48 006.
4. FUSE AS PER STANDARDS 60 00 07 15 50 010 AND 65 00 07 00 23 004.
5. FAULT INDICATORS TO BE INSTALLED ON THE "B" PRIMARY CABLE ONLY.
6. FOR ANCHOR DETAILS SEE STANDARD 65 00 07 00 23 003.
7. LIFTING EYES MUST BE ROTATED AND FACE DOWN.
8. ALL CABLES SHALL HAVE A MINIMUM OF 5 m OF EXTRA CABLE COILED IN THE BASE MEASURED FROM THE TOP OF PIPE OR BASE ENTRY POINT.
9. FOR PRECAST CONCRETE BASE INSTALLATION SEE 66 00 07 15 23 114.

20170605 11:00 r lawrie

<b>VOLUME 7 - C.O.E. DESIGN &amp; CONSTRUCTION STANDARDS</b>	
REVIEWED BY STANDARDS COMMITTEE:	2013-02-12
DRAFTED BY:	R. LAWRIE
DESIGNED BY:	A. RAHMAN
SCALE:	N. T. S.
DATE REVISED:	2017-05-31



<b>INSTALLATION OF 15kV 4-WAY SINGLE PHASE 200 AMP DEADFRONT SWITCHING CUBICLE</b>	
STANDARD NO.	PAGE NO.
<b>66 00 07 15 23 014</b>	1 / 3

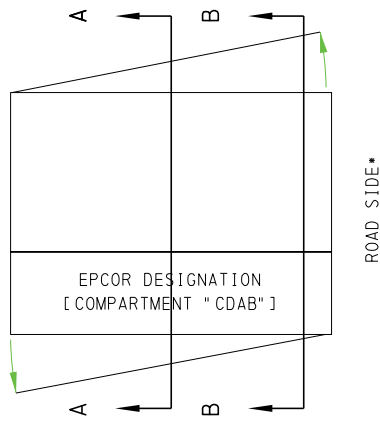

TOP VIEW

\* PREFERRED CUBICLE ORIENTATION IS AS SHOWN WHENEVER POSSIBLE. ALTERNATE ORIENTATIONS ARE ACCEPTABLE UNDER CERTAIN DESIGN CONSTRAINTS.

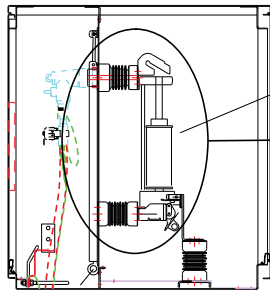

CLIP MOUNT FUSE FITTED SECTION THROUGH DETAIL A-A

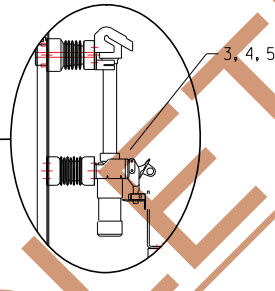

SME-4Z FUSE HOLDER [OPTIONAL]

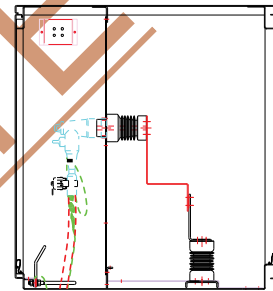

ELBOW CONNECTED CIRCUIT SECTION THROUGH DETAIL B-B

8S422DD\*\*\* (PMSG-SF4)

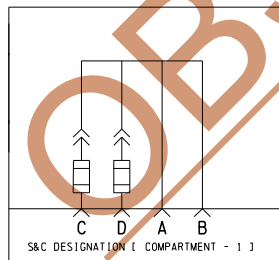

EPCOR DESIGNATION [COMPARTMENT "CDAB"]

CONNECTION DIAGRAM

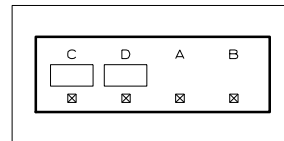

200A DEAD FRONT SWITCHING CUBICLE STOCK# 44215

SCHEMATIC

VOLUME 7 - C.O.E.  
DESIGN & CONSTRUCTION  
STANDARDS

REVIEWED BY STANDARDS  
COMMITTEE: 2013-02-12

DRAFTED BY: R. LAWRIE

DESIGNED BY: A. RAHMAN

SCALE: N. T. S.

DATE REVISED: 2017-05-31



INSTALLATION OF 15kV  
4-WAY SINGLE PHASE 200 AMP  
DEADFRONT SWITCHING CUBICLE

STANDARD NO.

66 00 07 15 23 014

PAGE NO.

2 / 3

20170605 11:04 r lawrie



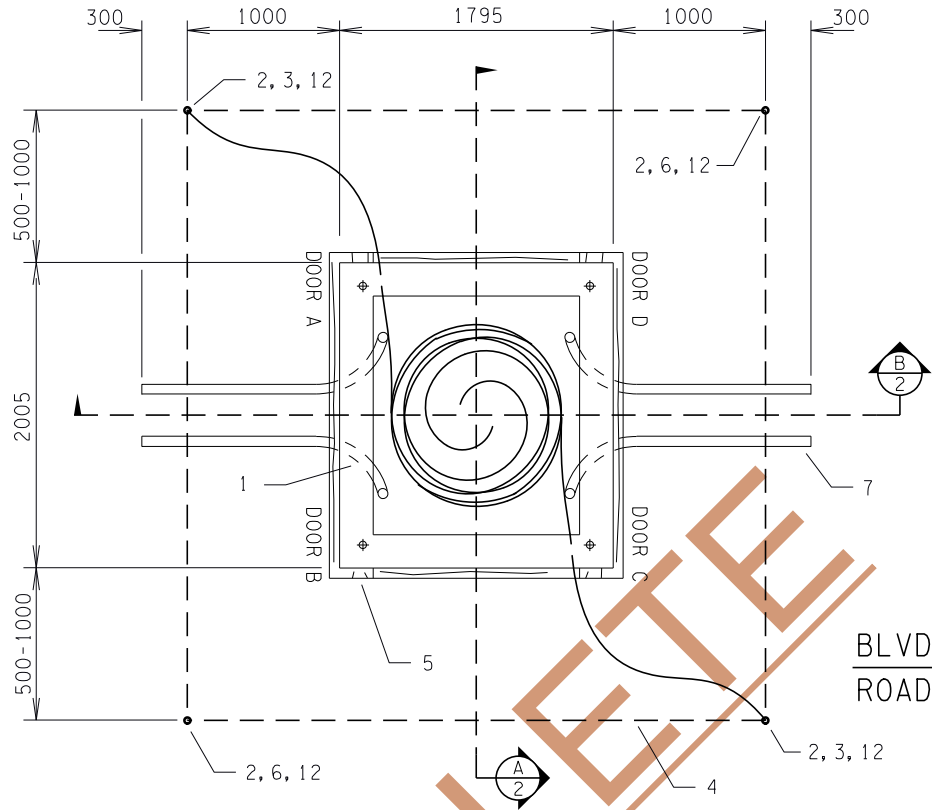

PLAN VIEW  
SCALE: N.T.S.

**NOTES:**

1. INTERCONNECTING GRADIENT CONTROL CONDUCTORS SHALL BE INSTALLED A MINIMUM OF 300 mm BELOW FINAL FINISHED GRADE (NOT ROUGH GRADE) WITH ONE LEG CONTINUOUS AROUND THE PERIMETER AND INTO THE BASE WITH AN ADDITIONAL CONTINUOUS CONDUCTOR TAIL ATTACHED FROM THE OPPOSITE CORNER.
2. USE FINE FILL CLAY BACKFILL AROUND GROUND GRID.
3. ENSURE TOP OF BASE IS BETWEEN 250 mm AND 300 mm FROM FINAL FINISHED GRADE (NOT ROUGH GRADE).
4. CABLES ARE TO BE INSTALLED THROUGH DUCTS ONLY.
5. RETAIN 5.0 m OF COILED 4/0 Cu FOR CONNECTION TO GROUND BUS.
6. PRIMARY CABLES ARE TO BE INSTALLED WITH 8 m COILED IN BASE PRIOR TO TERMINATION AND A MINIMUM OF ONE COMPLETE PERIMETER LOOP AFTER TERMINATION.
7. THE DUCTING SHOULD BE INSTALLED SO THAT THE ENDS ARE POINTING DIRECTLY UPWARDS WITH THE TOP OF THE END BELL 200 mm ABOVE THE PLANKS/BASE BOTTOM. SPARE DUCTS TO BE CAPPED AND TAPED.
8. ADDITIONAL GROUND ROD MAY BE REQUIRED TO ACHIEVE A RESISTANCE OF 6 OHMS OR LESS.
9. FOR CABLE BYPASS TROUGH REQUIREMENTS AND INSTALLATION SEE DRAWING 66 00 07 00 46 005.
10. THIS PRECAST BASE INSTALLATION STANDARD IS APPLICABLE FOR USE WITH THE FOLLOWING SWITCHING CUBICLE INSTALLATION STANDARDS: 65 00 07 15 23 030, 65 00 07 15 23 031, 65 00 07 15 23 032, 65 00 07 15 23 037, 66 00 07 15 23 035.
11. MECHANICAL PROTECTION FOR PADMOUNTED EQUIPMENT SHALL BE CONSIDERED AS PER CSA C22.3 No. 7-15 CLAUSE 10.5.
12. THE BASE SHALL BE INSTALLED SUCH THAT THE TOP SURFACE IS LEVEL.
13. BASE WEIGHT: 2400 kg (5300 lbs).

ALL DIMENSIONS IN MILLIMETERS ( INCHES) UNLESS OTHERWISE SPECIFIED.

20170705 12:11 r lawrie

<b>VOLUME 7 - C.O.E.</b> <b>DESIGN &amp; CONSTRUCTION</b> <b>STANDARDS</b>			<b>INSTALLATION OF</b> <b>PRECAST CONCRETE BASE FOR</b> <b>4-WAY 3 PHASE 15 kV</b> <b>SWITCHING CUBICLE</b> <b>( ALL VARIANTS)</b>	
REVIEWED BY STANDARDS COMMITTEE: 2017-05-26			STANDARD NO. <b>65 00 07 15 23 132</b>	PAGE NO. 1 / 6
DRAFTED BY: R. LAWRIE				
DESIGNED BY: M. MIX				
SCALE: N. T. S.				
DATE REVISED: 2017-06-30				

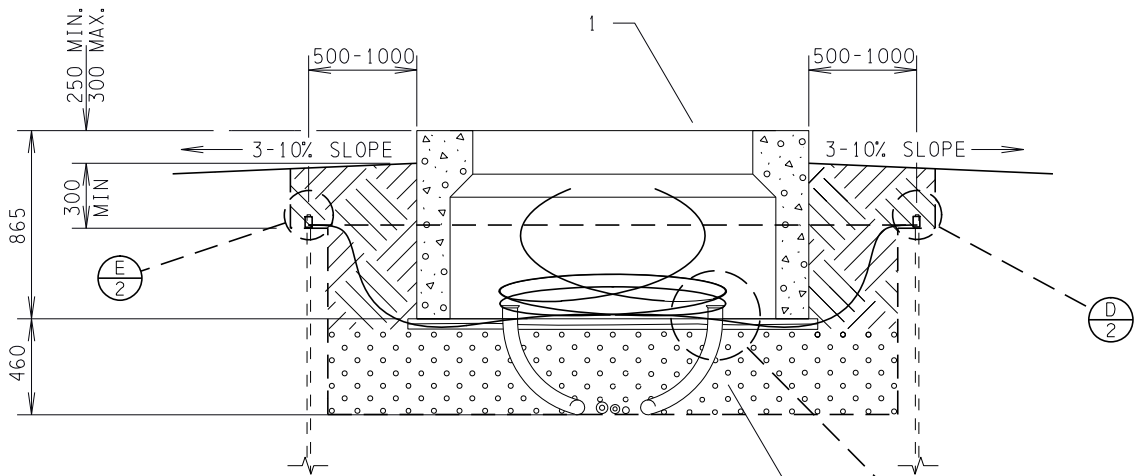

**A SECTION**  
SCALE: N.T.S.

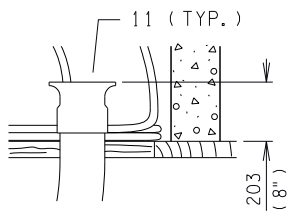

**C DETAIL**  
SCALE: N.T.S.

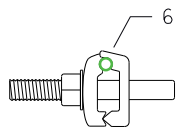

**E 1/C CONNECTOR**  
SCALE: N.T.S.

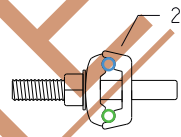

**D 2/C CONNECTOR**  
SCALE: N.T.S.

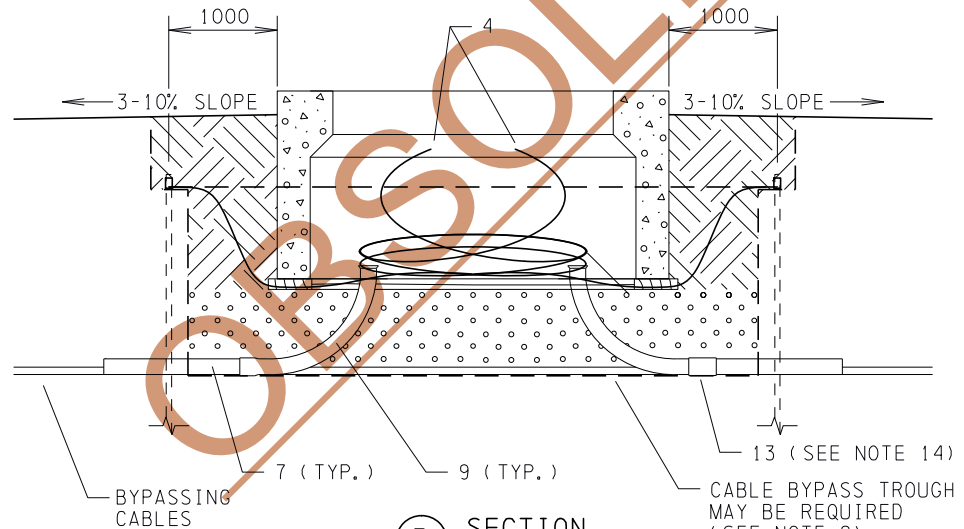

**B SECTION**  
SCALE: N.T.S.

**NOTES CONT'D:**

- 14. ADAPTER COUPLING IS REQUIRED FOR DB2 CONDUIT.
- 15. 36" RADIUS BENDS ARE PREFERRED FOR ALL DUCT BENDS.

ALL DIMENSIONS IN MILLIMETERS (INCHES) UNLESS OTHERWISE SPECIFIED.

<b>VOLUME 7 - C.O.E. DESIGN &amp; CONSTRUCTION STANDARDS</b>	
REVIEWED BY STANDARDS COMMITTEE:	2017-05-26
DRAFTED BY:	R. LAWRIE
DESIGNED BY:	M. MIX
SCALE:	N. T. S.
DATE REVISED:	2017-06-30



**INSTALLATION OF  
PRECAST CONCRETE BASE FOR  
4-WAY 3 PHASE 15 KV  
SWITCHING CUBICLE  
(ALL VARIANTS)**

STANDARD NO. <b>65 00 07 15 23 132</b>	PAGE NO. 2 / 6
-------------------------------------------	-------------------

20170705 12:17 r lawrie



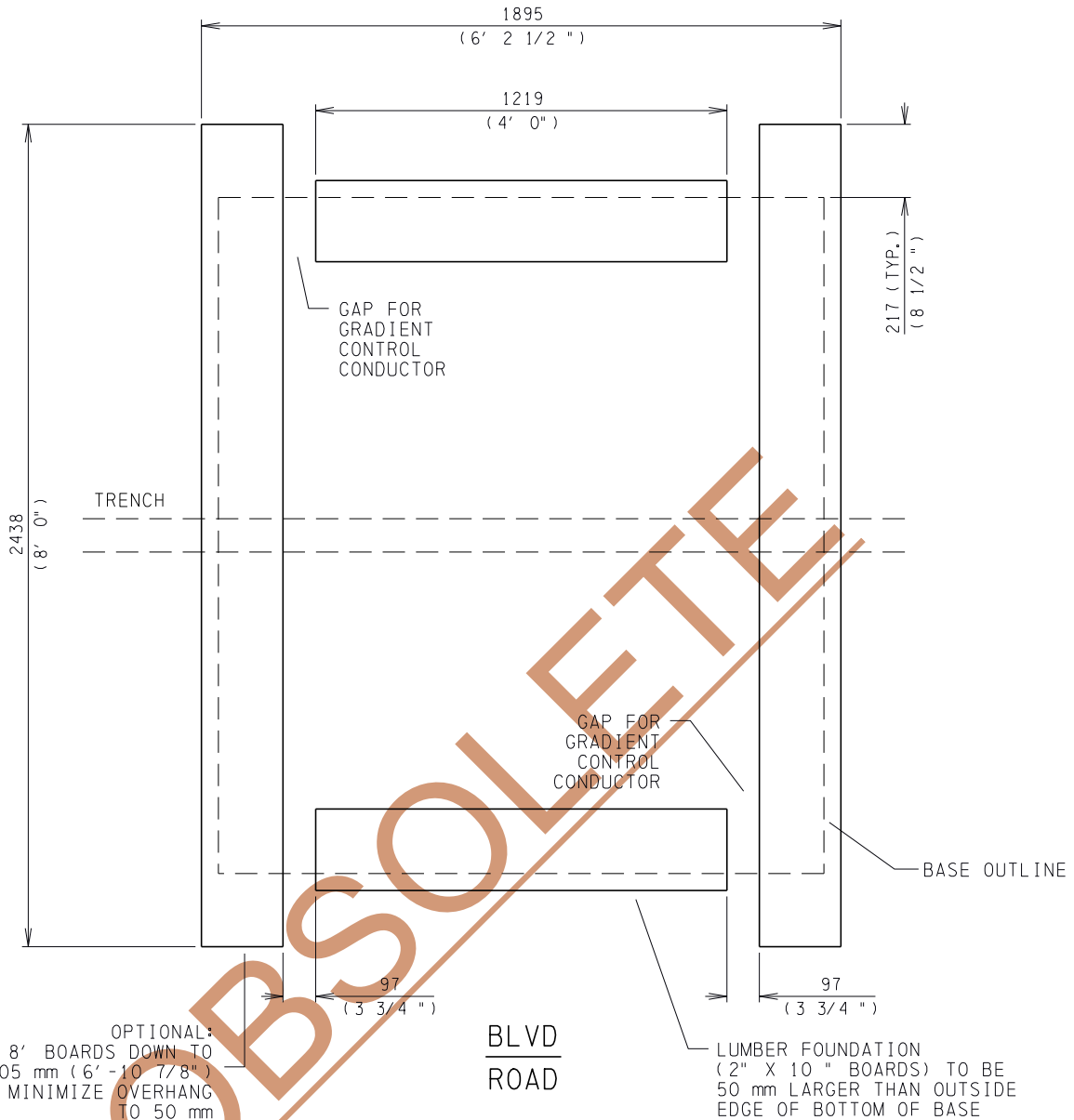

OPTIONAL:  
CUT 8' BOARDS DOWN TO  
2105 mm (6' - 10 7/8")  
TO MINIMIZE OVERHANG  
TO 50 mm

BLVD  
ROAD

LUMBER FOUNDATION  
(2" X 10" BOARDS) TO BE  
50 mm LARGER THAN OUTSIDE  
EDGE OF BOTTOM OF BASE

LUMBER FOUNDATION  
SCALE: N.T.S.

**NOTES CONT'D:**

16. LUMBER FOUNDATION SHOULD BE 2" x 10" x 8' PRESSURE TREATED SPRUCE WITH 2 - 2438 mm AND 2 - 1219 mm LENGTHS (50 mm MAXIMUM LEDGE ON OUTSIDE) (RE-TREAT ALL CUT ENDS).
17. RE-TREAT CUT ENDS OF LUMBER FOUNDATION BOARDS WITH COPPER NAPHTHANATE WOOD PRESERVATIVE.

ALL DIMENSIONS IN MILLIMETERS ( INCHES) UNLESS OTHERWISE SPECIFIED.

**VOLUME 7 - C.O.E.  
DESIGN & CONSTRUCTION  
STANDARDS**

REVIEWED BY STANDARDS  
COMMITTEE: 2017-05-26

DRAFTED BY: R. LAWRIE

DESIGNED BY: M. MIX

SCALE: N. T. S.

DATE REVISED: 2017-06-30



**INSTALLATION OF  
PRECAST CONCRETE BASE FOR  
4-WAY 3 PHASE 15 KV  
SWITCHING CUBICLE  
(ALL VARIANTS)**

STANDARD NO.  
**65 00 07 15 23 132**

PAGE NO.  
3 / 6

20170705 12:14 r lawrie

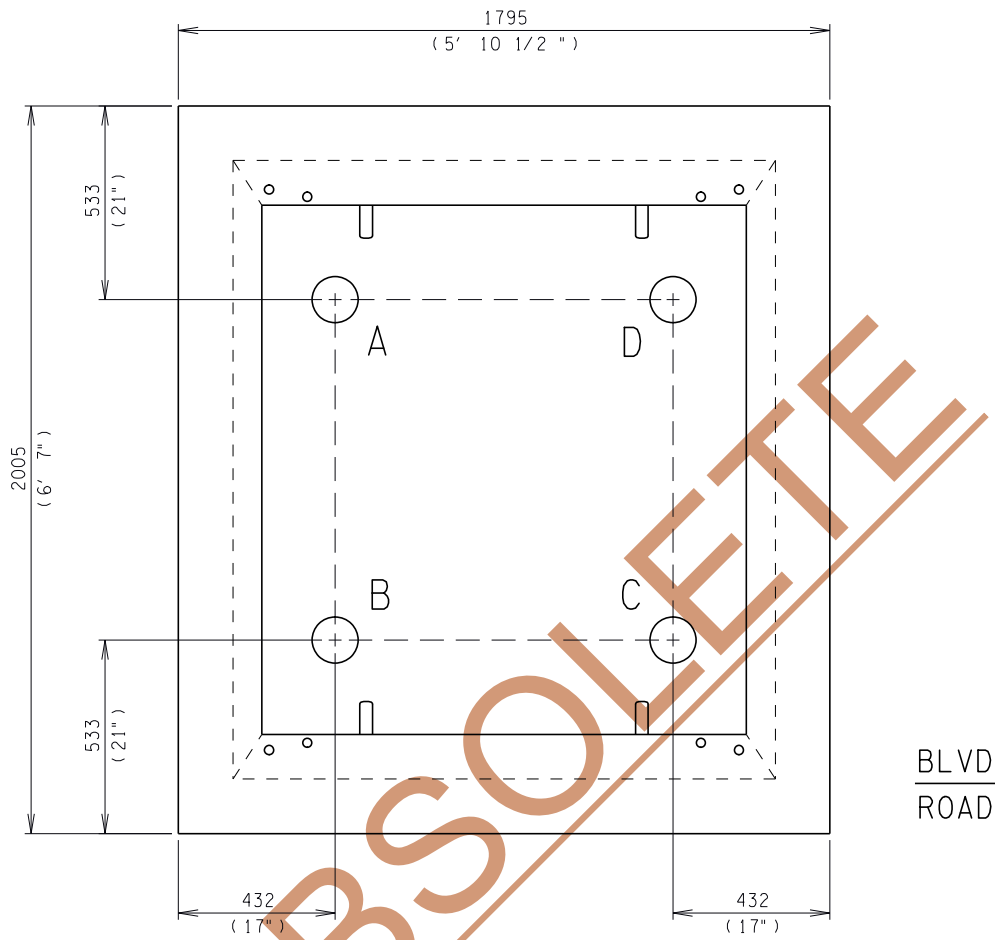

PIPE LOCATIONS  
SCALE: N.T.S.

NOTES CONT'D:

- 18. ALL PIPES SHALL BE DB2 OR SCHEDULE 40 PVC. CONDUIT BENDS SHALL BE SCHEDULE 40 PVC AND THE PREFERRED RADIUS IS 36".
- 19. DUCT SIZES AS PER STANDARD 63 00 07 00 37 001.
- 20. ALL MEASUREMENTS ARE TO THE OUTSIDE "TOP" OF THE BASE.

ALL DIMENSIONS IN MILLIMETERS (INCHES) UNLESS OTHERWISE SPECIFIED.

VOLUME 7 - C.O.E.  
DESIGN & CONSTRUCTION  
STANDARDS

REVIEWED BY STANDARDS  
COMMITTEE: 2017-05-26

DRAFTED BY: R. LAWRIE

DESIGNED BY: M. MIX

SCALE: N. T. S.

DATE REVISED: 2017-06-30



INSTALLATION OF  
PRECAST CONCRETE BASE FOR  
4-WAY 3 PHASE 15 KV  
SWITCHING CUBICLE  
(ALL VARIANTS)

STANDARD NO.

65 00 07 15 23 132

PAGE NO.

4 / 6

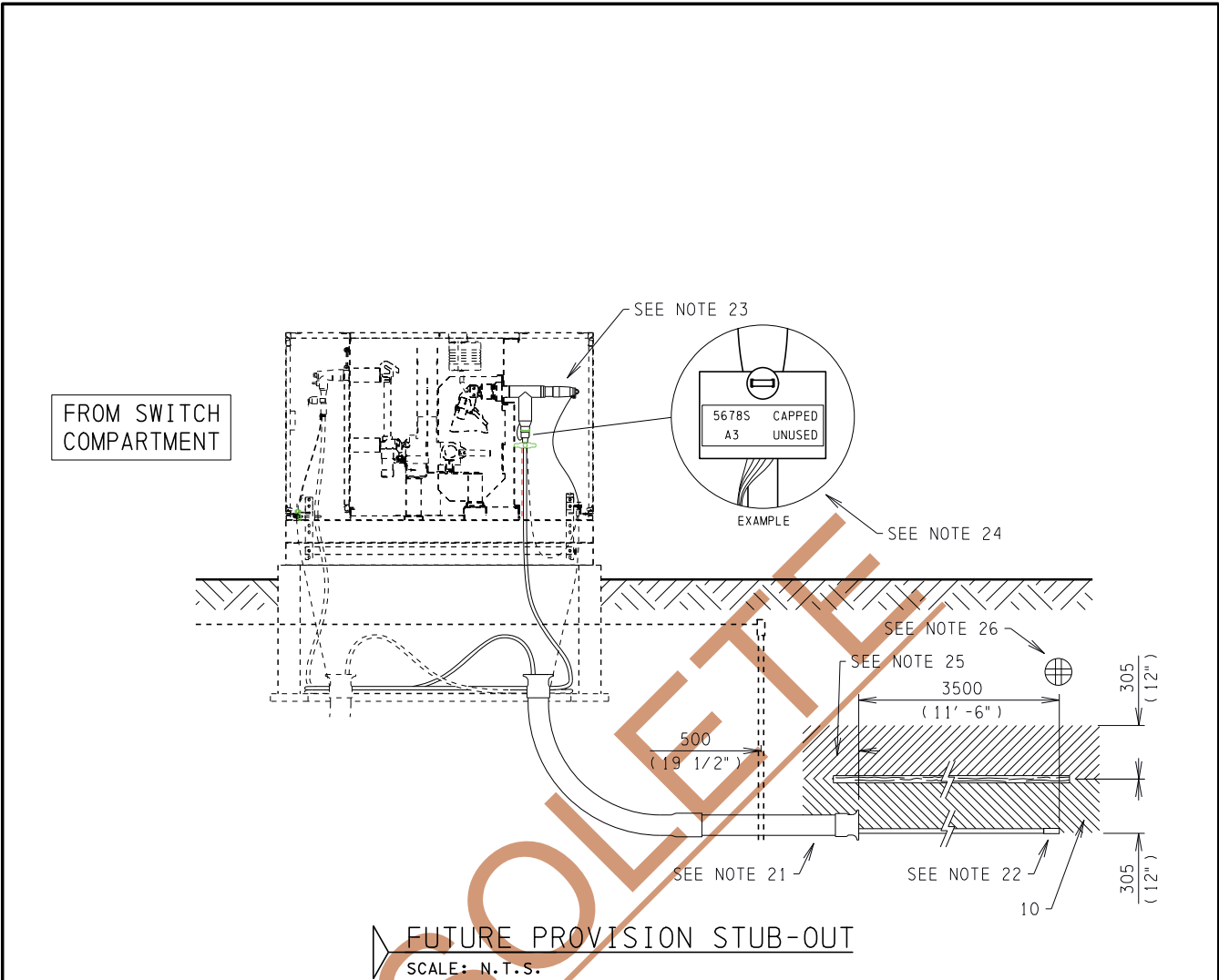

FUTURE PROVISION STUB-OUT  
SCALE: N.T.S.

NOTES CONT'D:

21. FOR UNUSED COMPARTMENTS STUB OUT A CONDUIT 500 mm PAST THE GROUND GRID FOR FUTURE PROVISION.
22. ENSURE 3.5 m OF CABLE EXTENDS PAST THE END OF THE CONDUIT STUB OUT AND HEAT SHRINK THE CABLE TAIL AS PER 6600070048175.
23. FOR STUBBED CABLES ORIGINATING FROM SWITCH COMPARTMENTS THE ELBOWS ARE TO BE PLACED ON THE BUSHING WITH THE SWITCH IN THE OFF POSITION AND A LOCK & TAG ON THE SWITCH TO PREVENT OPERATION. THE CABLE NEUTRAL AND TERMINATION GROUND ARE TO BE CONNECTED TO THE GROUND BUS.
24. USE CABLE IDENTIFICATION TAG TO INDICATE THE TERMINATED CABLE AS UNUSED AND CAPPED. SEE STANDARD 6600070020001 FOR IDENTIFICATION TAG DETAILS.
25. EXPOSED CABLE TAILS NOT PROTECTED INSIDE CONDUIT OR UNDER A TEMPORARY CONCRETE BASE MUST BE COVERED BY THE FOLLOWING IN ORDER: A 300 mm THICK LAYER OF SAND, 2" x 8" (MINIMUM) PRESSURE TREATED PLANKING BUTTED TOGETHER WITHOUT VOIDS OR GAPS, AN ADDITIONAL 300 mm THICK LAYER OF SAND, AND FINALLY BACKFILLED TO GRADE AS PER SECTION A & B ON THIS DRAWING.
26. MARKER BALLS SHALL BE PLACED ABOVE THE CABLE TAIL ENDS. REFER TO STANDARD 6300070017001 OR A PRECAST BASE MAY BE USED AS PER STANDARD 66 00 07 00 48 100.

ALL DIMENSIONS IN MILLIMETERS ( INCHES ) UNLESS OTHERWISE SPECIFIED.

20170705 12:15 r lawrie

<b>VOLUME 7 - C.O.E.</b> <b>DESIGN &amp; CONSTRUCTION</b> <b>STANDARDS</b>		<b>INSTALLATION OF</b> <b>PRECAST CONCRETE BASE FOR</b> <b>4-WAY 3 PHASE 15 KV</b> <b>SWITCHING CUBICLE</b> <b>( ALL VARIANTS )</b>	
REVIEWED BY STANDARDS COMMITTEE: 2017-05-26		STANDARD NO.	PAGE NO.
DRAFTED BY: R. LAWRIE		<b>65 00 07 15 23 132</b>	5 / 6
DESIGNED BY: M. MIX			
SCALE: N. T. S. DATE REVISED: 2017-06-30			

ITEM	PART DESCRIPTION	STOCK No.	QTY.
1	BASE PRECAST 600 AMP 15 kV 4-WAY 3 PHASE DEADFRONT SWITCHING CUBICLE	17282	1
2	ROD GROUNDING 5/8" x 5' (SEE NOTE 8)	17288	8
3	CONNECTOR GROUND ROD 3/4" - 250 DOUBLE WIRE	9136	2
4	WIRE #4/0 STRANDED COPPER BARE (SEE NOTE 5)	45655	36m
5	LUMBER SPRUCE PRESSURE-TREATED - 2" x 10" x 8' PWF (RE-TREAT CUT ENDS)	13235	3
6	CONNECTOR GROUND 3/4" ROD - 250 1/C	31914	2
7	PIPE DUCT 20 FT.	AS REQ' D	A/R
	DB2 - 4"	53283	
	DB2 - 6"	42236	
	RIGID PVC - 4"	10083	
	RIGID PVC - 6"	10692	
8	ROAD CRUSH - 3/4"	N/A	A/R
9	BENDS RIGID PVC	AS REQ' D	A/R
	4" - 90 DEGREE 24" RADIUS PLAIN ENDS	44327	
	4" - 90 DEGREE 24" RADIUS PLAIN ENDS	22960	
	6" - 90 DEGREE 36" RADIUS PLAIN ENDS	17787	
10	SAND	N/A	A/R
11	END BELL COLLAR	AS REQ' D	A/R
	RIGID PVC - 4"	20574	
	RIGID PVC - 6"	20889	
12	COUPLER - GROUND ROD	17289	4
13	COUPLING ADAPTER	AS REQ' D	A/R
	4" DB2 TO 4" PVC	38916	
	6" DB2 TO 6" PVC	10284	

OBSOLETE

**VOLUME 7 - C.O.E.  
DESIGN & CONSTRUCTION  
STANDARDS**

---

REVIEWED BY STANDARDS COMMITTEE: 2017-05-26

---

DRAFTED BY: R. LAWRIE

---

DESIGNED BY: M. MIX

---

SCALE: N. T. S.

---

DATE REVISED: 2017-06-30



**INSTALLATION OF  
PRECAST CONCRETE BASE FOR  
4-WAY 3 PHASE 15 kV  
SWITCHING CUBICLE  
(ALL VARIANTS)**

---

<b>STANDARD NO. 65 00 07 15 23 132</b>	<b>PAGE NO. 6 / 6</b>
--------------------------------------------	---------------------------

20170705 12:18 r.lawrie

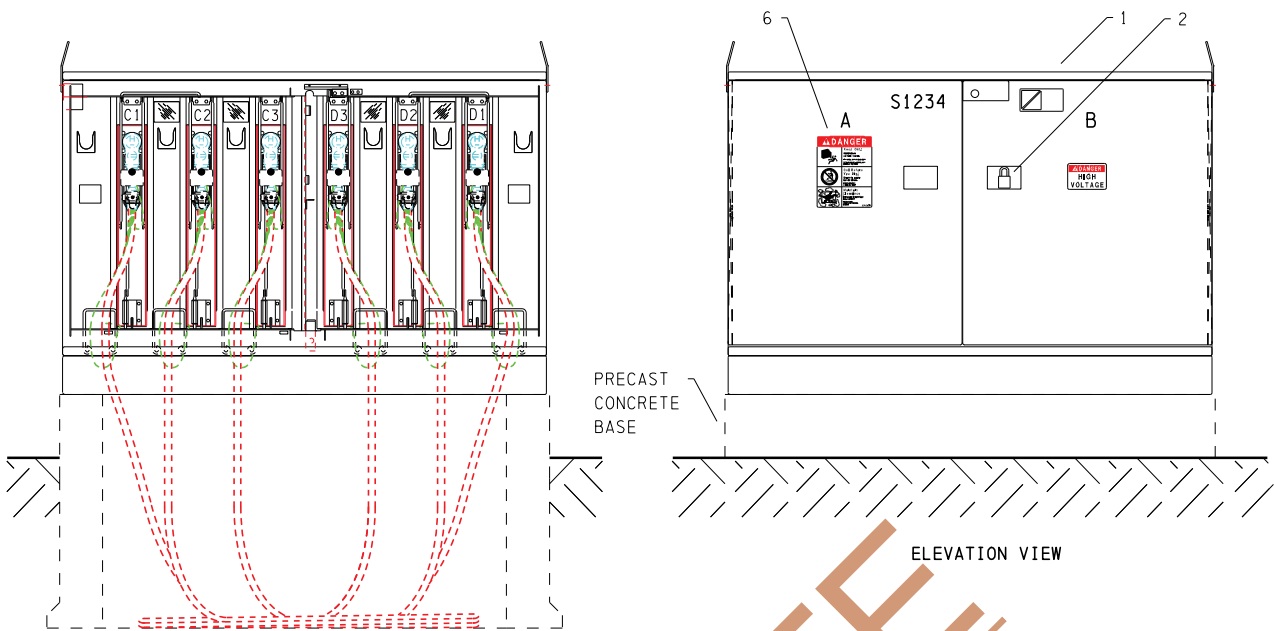

15T422DD\*\*\* (PMSG-200-9) & 15T421DD\*\*\* (PMSG-200-12)  
FUSE COMPARTMENT (C & D)

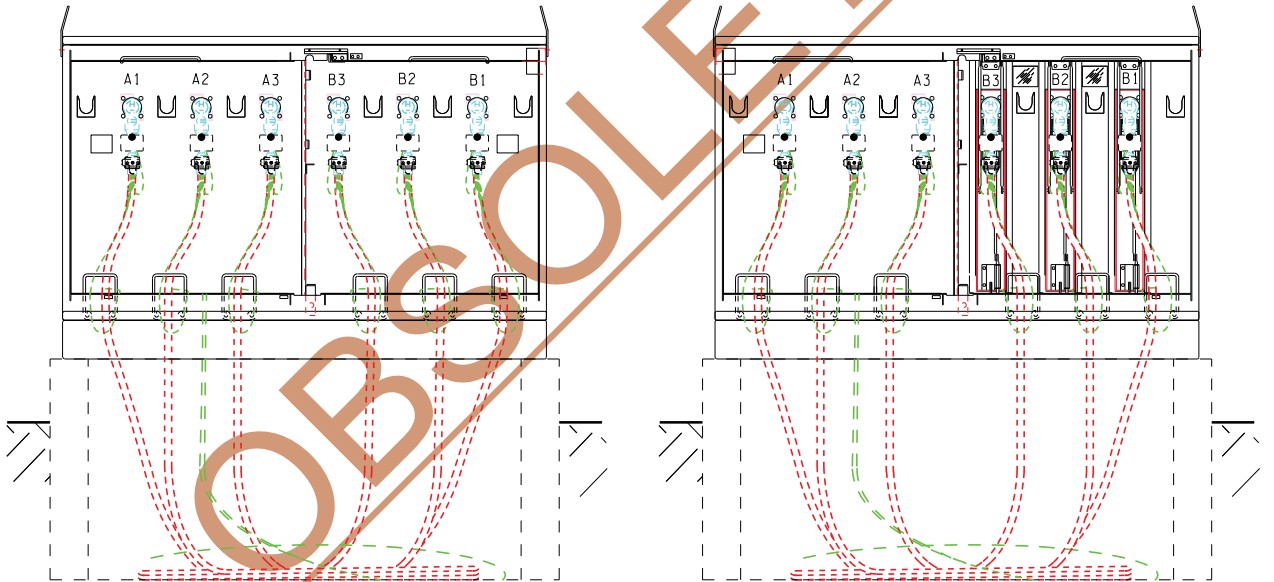

15T422DD\*\*\* (PMSG-200-9)  
FEED THROUGH COMPARTMENT (A & B)

15T421DD\*\*\* (PMSG-200-12)  
FEED THROUGH & FUSE COMPARTMENT (A & B)

20170605 11:36 r lawrie

**VOLUME 7 - C.O.E.  
DESIGN & CONSTRUCTION  
STANDARDS**

REVIEWED BY STANDARDS COMMITTEE:	2013-02-12
DRAFTED BY:	R. LAWRIE
DESIGNED BY:	A. RAHMAN
SCALE:	N. T. S.
DATE REVISED:	2017-01-06



**INSTALLATION OF 15 KV  
4-WAY 3 PHASE 200 AMP  
DEADFRONT SWITCHING CUBICLE**

STANDARD NO.	PAGE NO.
66 00 07 15 23 035	1 / 4

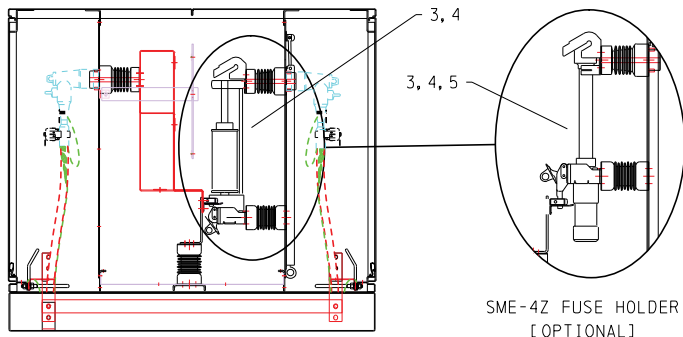
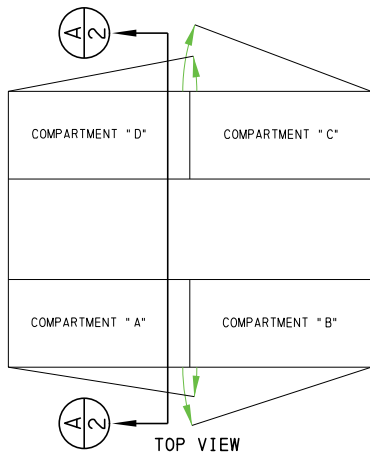

CLIP MOUNT FUSE FITTED  
SECTION THROUGH DETAIL A-A

15T422DD\*\*\* (PMSG-200-9)

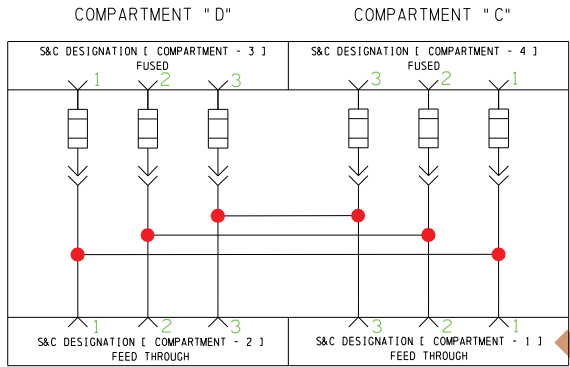

COMPARTMENT "A" COMPARTMENT "B"  
CONNECTION DIAGRAM

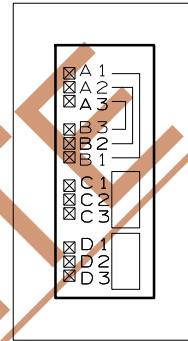

200A DEADFRONT  
SWITCHING CUBICLE STOCK# 45777

SCHEMATIC

15T421DD\*\*\* (PMSG-200-12)

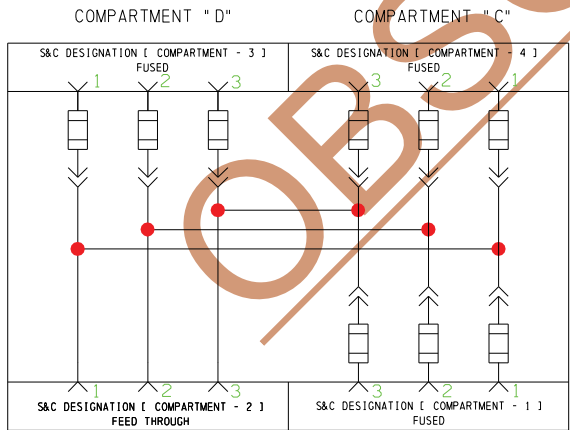

COMPARTMENT "A" COMPARTMENT "B"  
CONNECTION DIAGRAM

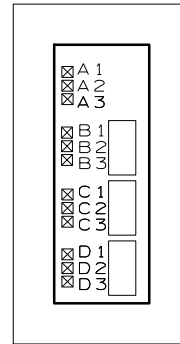

200A DEADFRONT  
SWITCHING CUBICLE STOCK# 33243

SCHEMATIC

VOLUME 7 - C.O.E.  
DESIGN & CONSTRUCTION  
STANDARDS

REVIEWED BY STANDARDS  
COMMITTEE: 2013-02-12  
DRAFTED BY: R. LAWRIE  
DESIGNED BY: A. RAHMAN  
SCALE: N. T. S.  
DATE REVISED: 2017-01-06



INSTALLATION OF 15 kV  
4-WAY 3 PHASE 200 AMP  
DEADFRONT SWITCHING CUBICLE

STANDARD NO.

66 00 07 15 23 035

PAGE NO.

2 / 4

**NOTES:**

1. GROUNDING CONNECTION AND DETAILS SHOULD BE AS PER STANDARD 65 00 07 00 60 001.
2. PHYSICAL LOCATION OF SWITCHES & FUSES ARE AS PER SCHEMATICS (SEE PAGE 2).
3. LOAD BREAK ELBOWS ARE TERMINATED AS PER STANDARD 63 00 07 00 48 006.
4. DEAD BREAK ELBOWS ARE TERMINATED AS PER STANDARD 63 00 07 00 48 005.
5. FUSE AS PER STANDARDS 60 00 07 15 50 030 AND 65 00 07 00 23 004.
6. FIBRE OPTICS TO BE INSTALLED AS PER STANDARD 63 00 07 00 23 001.
7. FAULT INDICATORS ARE REQUIRED ON ALL PRIMARY CABLES EXCEPT ON CABLES DIRECTLY FEEDING A 3 PHASE TRANSFORMER.
8. LIFTING EYES MUST BE ROTATED AND FACE DOWN.
9. FOR ANCHORING DETAILS SEE STANDARD 65 00 07 00 23 003.
10. ALL CABLES SHALL HAVE A MINIMUM OF 8 m OF EXTRA CABLE COILED IN THE BASE MEASURE FROM THE TOP OF PIPE OR BASE ENTRY POINT.
11. FOR PRECAST BASE INSTALLATION SEE 65 00 07 15 23 132.

**OBSOLETE**

**VOLUME 7 - C.O.E.  
DESIGN & CONSTRUCTION  
STANDARDS**

REVIEWED BY STANDARDS  
COMMITTEE: 2013-02-12

DRAFTED BY: R. LAWRIE

DESIGNED BY: A. RAHMAN

SCALE: N. T. S.

DATE REVISED: 2017-01-06



**INSTALLATION OF 15 kV  
4-WAY 3 PHASE 200 AMP  
DEADFRONT SWITCHING CUBICLE**

STANDARD NO.

**66 00 07 15 23 035**

PAGE NO.

3 / 4





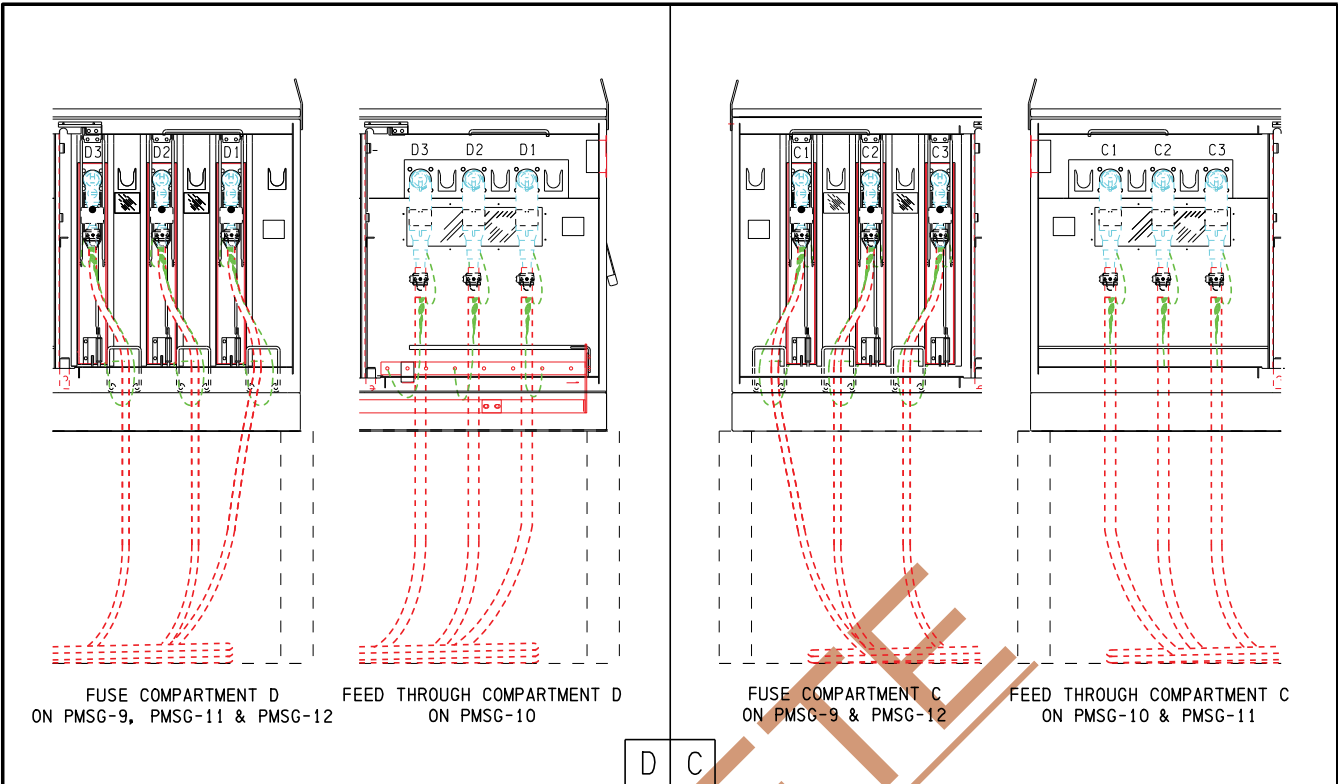

FUSE COMPARTMENT D  
ON PMSG-9, PMSG-11 & PMSG-12

FEED THROUGH COMPARTMENT D  
ON PMSG-10

FUSE COMPARTMENT C  
ON PMSG-9 & PMSG-12

FEED THROUGH COMPARTMENT C  
ON PMSG-10 & PMSG-11

D	C
A	B

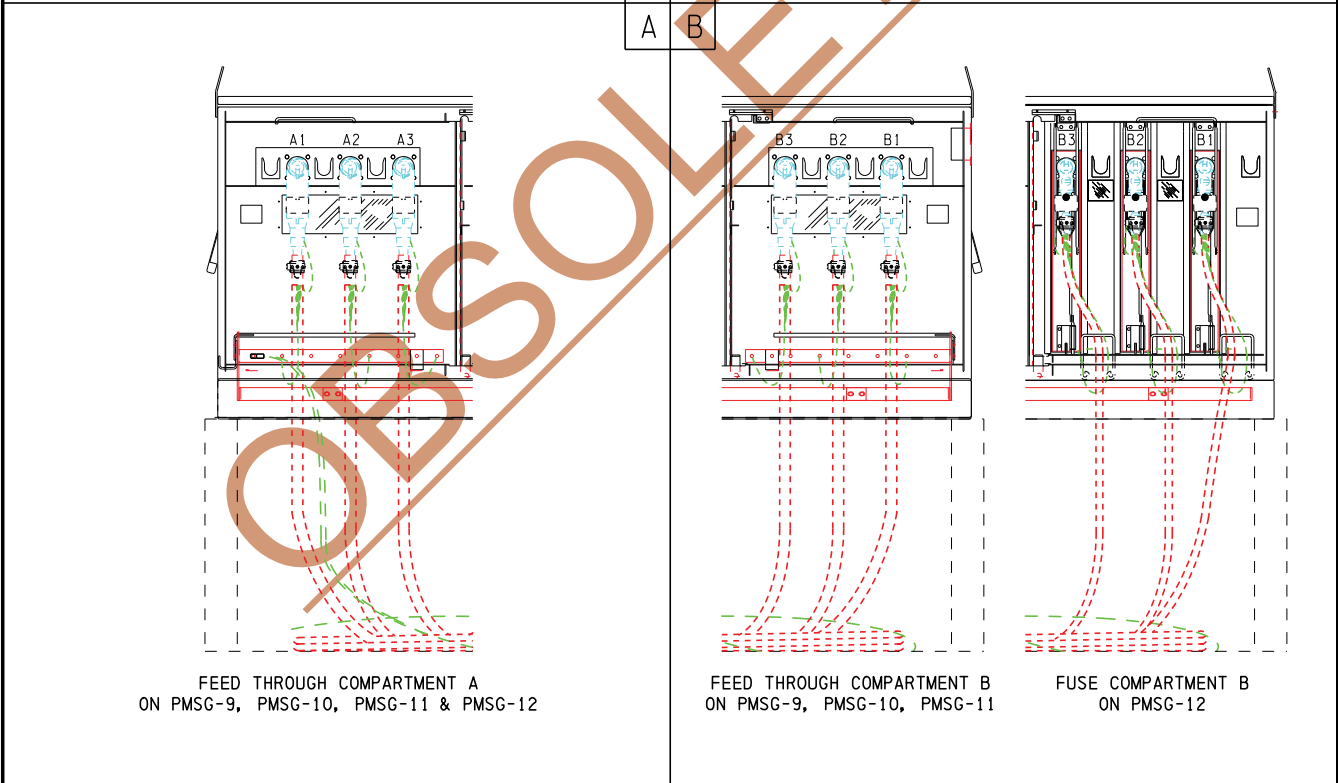

FEED THROUGH COMPARTMENT A  
ON PMSG-9, PMSG-10, PMSG-11 & PMSG-12

FEED THROUGH COMPARTMENT B  
ON PMSG-9, PMSG-10, PMSG-11

FUSE COMPARTMENT B  
ON PMSG-12

20170602 11:22 r lawrie 1:35

**VOLUME 7 - C.O.E.  
DESIGN & CONSTRUCTION  
STANDARDS**

REVIEWED BY STANDARDS COMMITTEE:	2013-02-12
DRAFTED BY:	R. LAWRIE
DESIGNED BY:	A. RAHMAN
SCALE:	N. T. S.
DATE REVISED:	2017-01-05



**INSTALLATION OF 15 kV  
4-WAY 3 PHASE 600 AMP  
DEADFRONT SWITCHING CUBICLES  
[ALL VARIANTS]**

STANDARD NO.	PAGE NO.
65 00 07 15 23 032	1 / 5

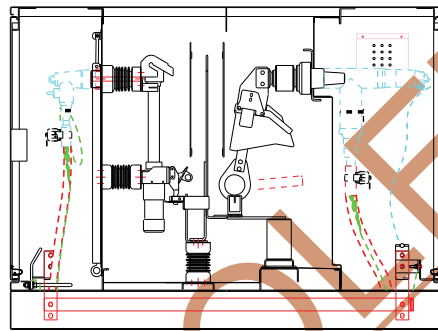
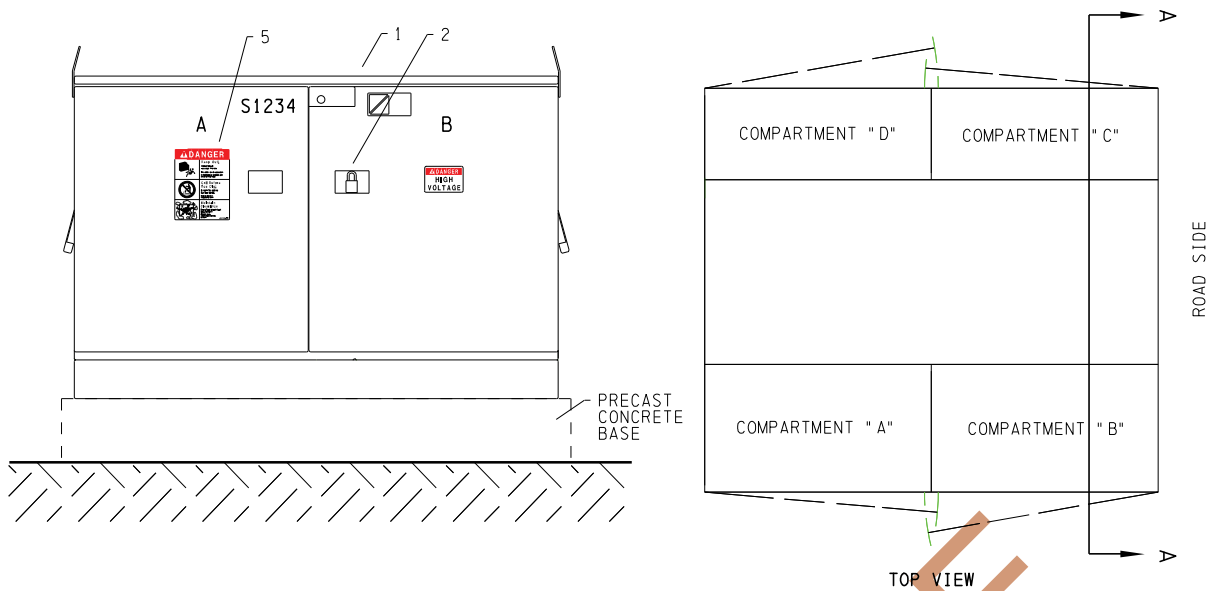

SME-4Z FUSE FITTED  
SECTION THROUGH DETAIL A-A  
(PMSG-9)

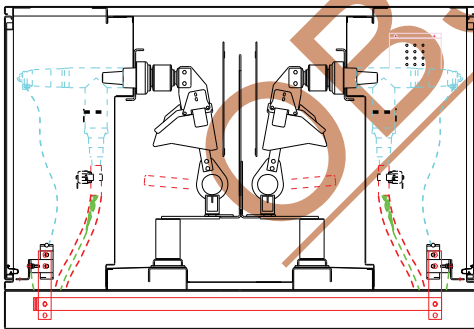

SECTION THROUGH DETAIL A-A  
(PMSG-10, PMSG-11)

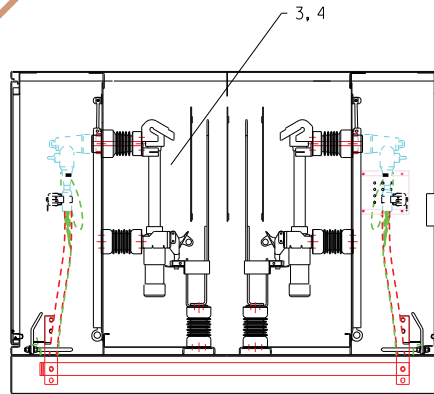

SME-4Z FUSE FITTED  
SECTION THROUGH DETAIL A-A  
(PMSG-12)

VOLUME 7 - C.O.E.  
DESIGN & CONSTRUCTION  
STANDARDS

REVIEWED BY STANDARDS  
COMMITTEE: 2013-02-12  
DRAFTED BY: R. LAWRIE  
DESIGNED BY: A. RAHMAN  
SCALE: N. T. S.  
DATE REVISED: 2017-01-05



INSTALLATION OF 15 KV  
4-WAY 3 PHASE 600 AMP  
DEADFRONT SWITCHING CUBICLES  
[ ALL VARIANTS ]

STANDARD NO.  
65 00 07 15 23 032

PAGE NO.  
2 / 5

15T462DD\*\*\*

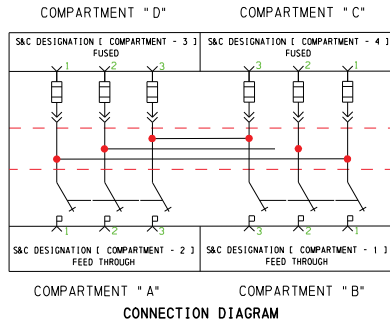

PMSG-9

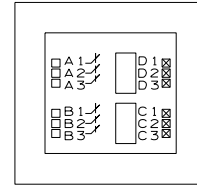

15T464DD\*\*\*

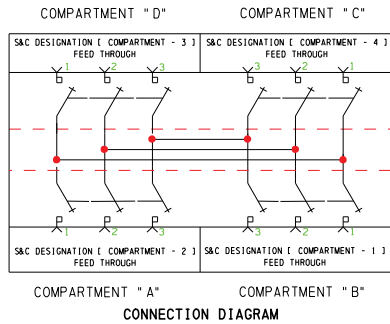

PMSG-10

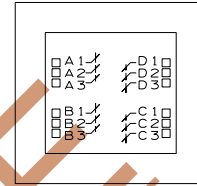

15T463DD\*\*\*

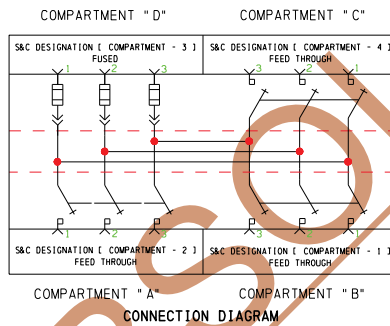

PMSG-11

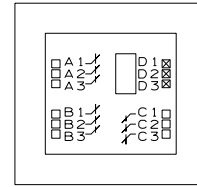

15T461DD\*\*\*

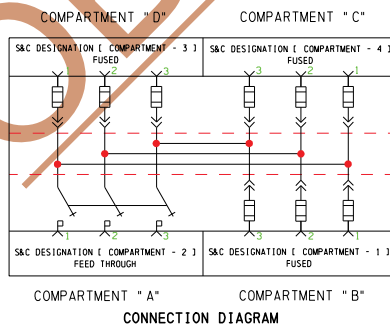

PMSG-12

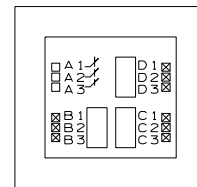

VOLUME 7 - C.O.E.  
DESIGN & CONSTRUCTION  
STANDARDS

REVIEWED BY STANDARDS  
COMMITTEE: 2013-02-12

DRAFTED BY: R. LAWRIE

DESIGNED BY: A. RAHMAN

SCALE: N. T. S.

DATE REVISED: 2017-01-05



INSTALLATION OF 15 kV  
4-WAY 3 PHASE 600 AMP  
DEADFRONT SWITCHING CUBICLES  
[ ALL VARIANTS ]

STANDARD NO.

65 00 07 15 23 032

PAGE NO.

3 / 5

20170602 11:22 r lawrie

**NOTES:**

1. GROUNDING CONNECTION AND DETAILS SHOULD BE AS PER STANDARD 65 00 07 00 60 001.
2. PHYSICAL LOCATION OF SWITCHES & FUSES ARE AS PER SCHEMATICS (SEE PAGE 2).
3. LOAD BREAK ELBOWS ARE TERMINATED AS PER STANDARD 63 00 07 00 48 006.
4. DEAD BREAK ELBOWS ARE TERMINATED AS PER STANDARD 63 00 07 00 48 005 OR 63 00 07 15 48 005.
5. FUSE AS PER STANDARDS 60 00 07 15 50 030 AND 65 00 07 00 23 004.
6. FIBRE OPTICS TO BE INSTALLED AS PER STANDARD 63 00 07 00 23 001.
7. FAULT INDICATORS ARE REQUIRED ON ALL PRIMARY CABLES EXCEPT CABLES DIRECTLY FEEDING A 3 PHASE TRANSFORMER.
8. LIFTING EYES MUST BE ROTATED AND FACE DOWN.
9. FOR ANCHORING DETAILS SEE STANDARD 65 00 07 00 23 003.
10. ALL CABLES SHALL HAVE A MINIMUM OF 8 m OF EXTRA CABLE COILED IN THE BASE MEASURED FROM THE TOP OF PIPE OR BASE ENTRY POINT.
11. FOR PRECAST BASE INSTALLATION SEE 65 00 07 15 23 132.

**OBSOLETE**

**VOLUME 7 - C.O.E.  
DESIGN & CONSTRUCTION  
STANDARDS**

REVIEWED BY STANDARDS  
COMMITTEE: 2013-02-12

DRAFTED BY: R. LAWRIE

DESIGNED BY: A. RAHMAN

SCALE: N. T. S.

DATE REVISED: 2017-01-05



**INSTALLATION OF 15 kV  
4-WAY 3 PHASE 600 AMP  
DEADFRONT SWITCHING CUBICLES  
[ALL VARIANTS]**

STANDARD NO.

**65 00 07 15 23 032**

PAGE NO.

4 / 5



20170602 11:11 r lowrie 1:35

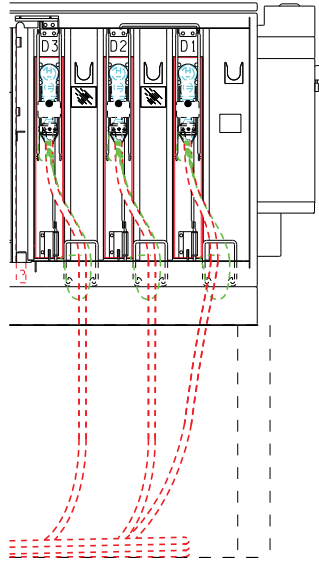

FUSE COMPARTMENT D  
ON PMSG-9 & PMSG-11

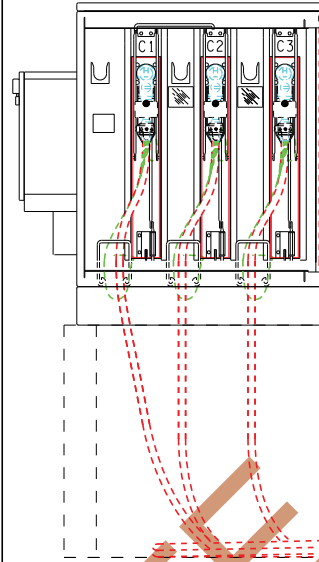

FUSE COMPARTMENT C  
ON PMSG-9

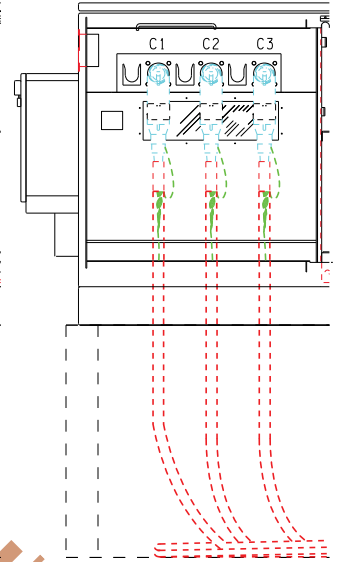

FEED THROUGH  
COMPARTMENT C  
ON PMSG-11

D	C
A	B

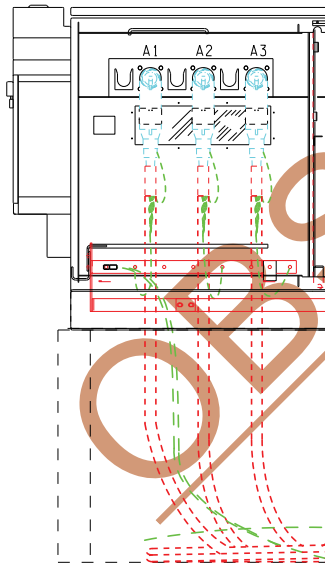

FEED THROUGH COMPARTMENT A  
ON PMSG-9 & PMSG-11

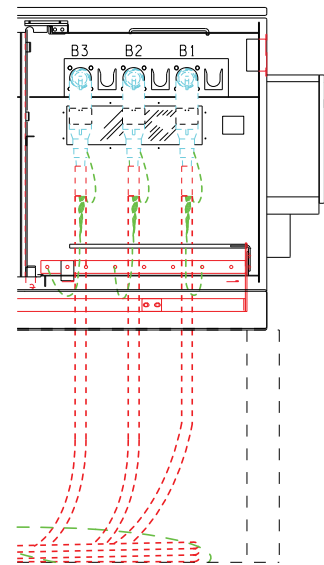

FEED THROUGH COMPARTMENT B  
ON PMSG-9 & PMSG-11

**VOLUME 7 - C.O.E.  
DESIGN & CONSTRUCTION  
STANDARDS**

REVIEWED BY STANDARDS  
COMMITTEE: 2013-08-27

DRAFTED BY: R. SARNECKI

DESIGNED BY: A. RAHMAN

SCALE: N. T. S.

DATE REVISED: 2017-01-05



**INSTALLATION OF 15 kV  
4-WAY 3 PHASE 600 AMP  
DEADFRONT SWITCHING CUBICLES  
FOR DISTRIBUTION  
AUTOMATION**

STANDARD NO.  
**65 00 07 15 23 030**

PAGE NO.  
1 / 4

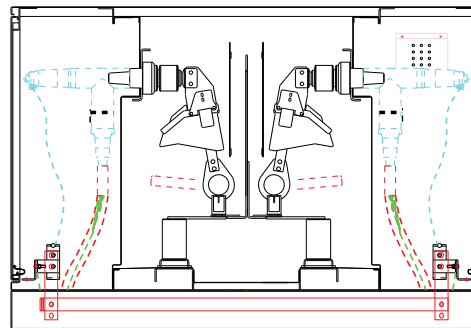
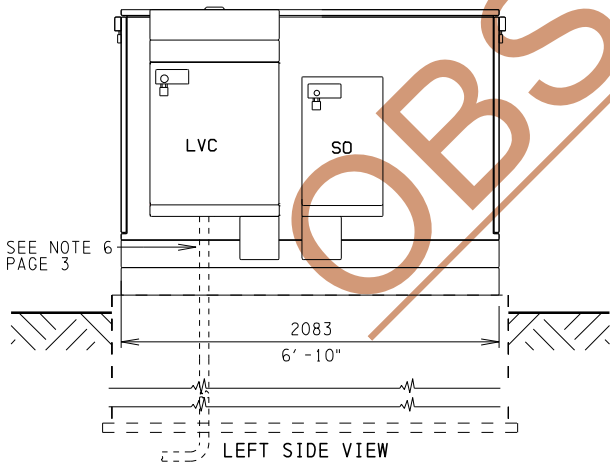
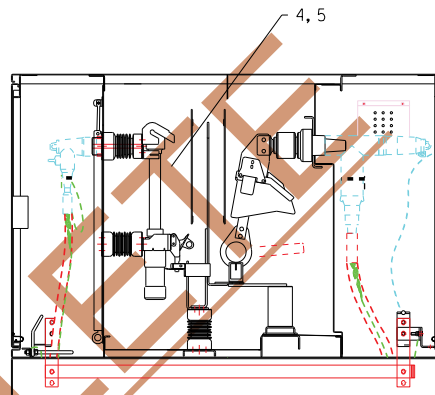
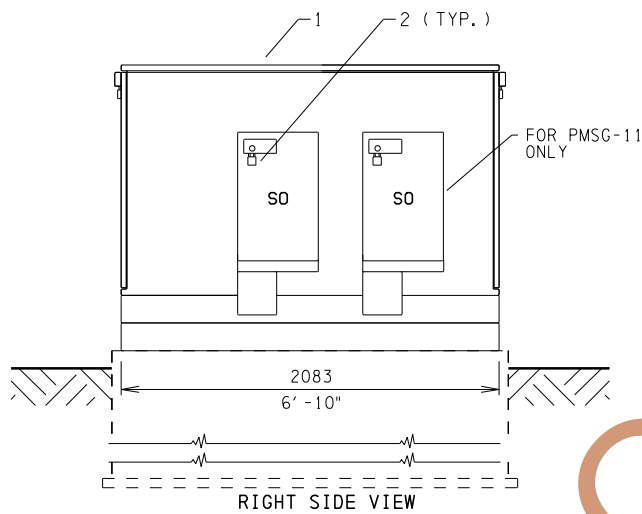
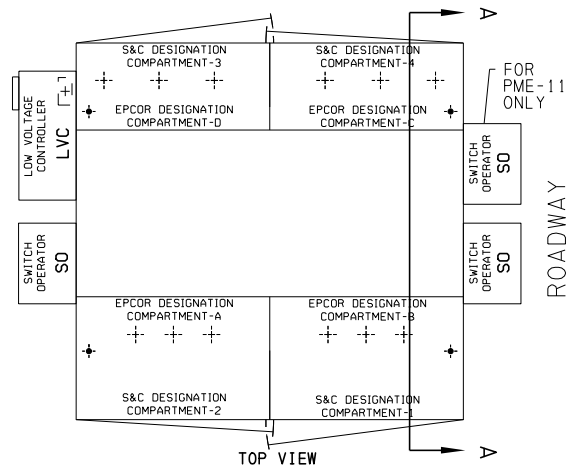
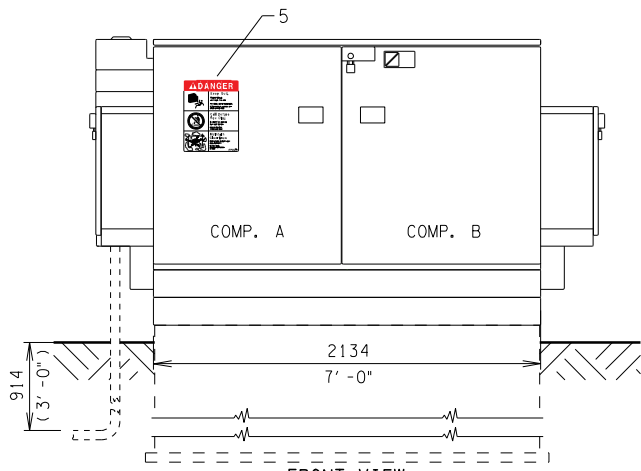

ALL DIMENSIONS ARE IN MILLIMETERS (INCHES) UNLESS OTHERWISE INDICATED

**VOLUME 7 - C.O.E.  
DESIGN & CONSTRUCTION  
STANDARDS**

REVIEWED BY STANDARDS COMMITTEE: 2013-08-27  
 DRAFTED BY: R. SARNECKI  
 DESIGNED BY: A. RAHMAN  
 SCALE: N. T. S.  
 DATE REVISED: 2017-01-05



**INSTALLATION OF 15 kV  
4-WAY 3 PHASE 600 AMP  
DEADFRONT SWITCHING CUBICLES  
FOR DISTRIBUTION  
AUTOMATION**

STANDARD NO.  
**65 00 07 15 23 030**

PAGE NO.  
2 / 4

15T462DDA\*\*\*

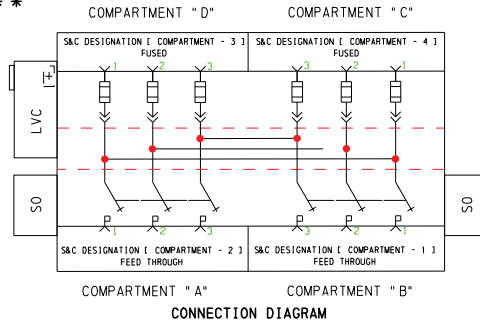

PMSG-9

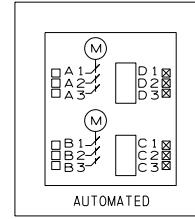

SWITCHING CUBICLE STOCK# 12583  
SCHEMATIC

15T463DDA\*\*\*

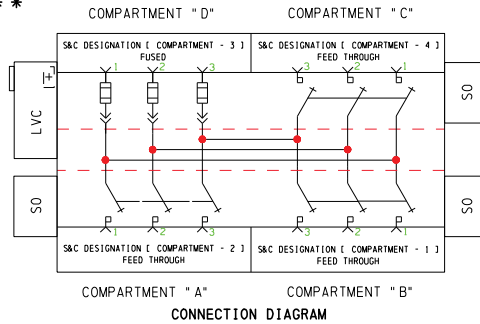

PMSG-11

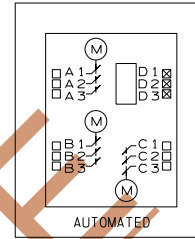

SWITCHING CUBICLE STOCK# 12584  
SCHEMATIC

NOTE: PMSG-10 & PMSG-12 ARE NOT AVAILABLE.

**NOTES:**

1. GROUNDING CONNECTION AND DETAILS SHOULD BE AS PER STANDARD 65 00 07 00 60 001.
2. PHYSICAL LOCATION OF SWITCHES AS PER PAGE 2 & FUSES ARE AS PER SCHEMATICS ON THIS PAGE.
3. LOAD BREAK ELBOWS ARE TERMINATED AS PER STANDARD 63 00 07 00 48 006.
4. DEAD BREAK ELBOWS ARE TERMINATED AS PER STANDARD 63 00 07 00 48 007.
5. FUSE AS PER STANDARD 60 00 07 15 50 030.
6. IF AN EXTERNAL ANTENNA IS REQUIRED, A 51 mm (2") FLEXIBLE CONDUIT MUST BE INSTALLED INTO THE LOW VOLTAGE CONTOLLER COMPARTMENT. FIELD DRILL INTO THE LVC IS NECESSARY TO ACCOMODATE THE 2" FLEXIBLE CONDUIT.
7. LIFTING EYES MUST BE ROTATED AND FACE DOWN.
8. FOR ANCHORING DETAILS SEE STANDARD 65 00 07 00 23 003.
9. ALL CABLES SHALL HAVE A MINIMUM OF 8 m OF EXTRA CABLE COILED IN THE BASE MEASURED FROM THE TOP OF PIPE OR BASE ENTRY POINT.
10. FOR PRECAST BASE INSTALLATION SEE 65 00 07 15 23 132.

20170602 11:11 r lowrie

**VOLUME 7 - C.O.E.  
DESIGN & CONSTRUCTION  
STANDARDS**

REVIEWED BY STANDARDS  
COMMITTEE: 2013-08-27

DRAFTED BY: R. SARNECKI

DESIGNED BY: A. RAHMAN

SCALE: N. T. S.

DATE REVISED: 2017-01-05



**INSTALLATION OF 15 kV  
4-WAY 3 PHASE 600 AMP  
DEADFRONT SWITCHING CUBICLES  
FOR DISTRIBUTION  
AUTOMATION**

STANDARD NO.  
**65 00 07 15 23 030**

PAGE NO.  
3 / 4





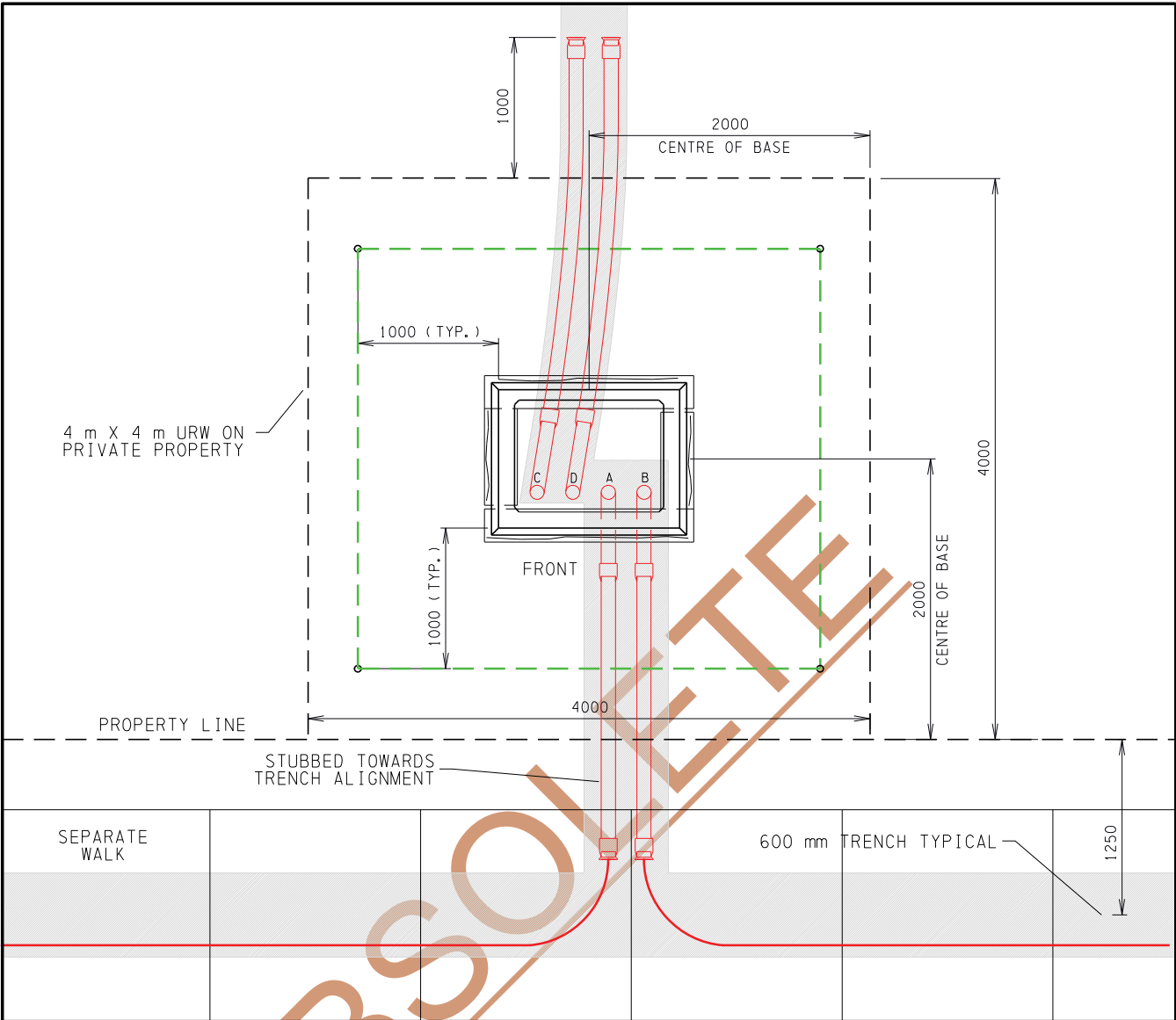

URW INSTALLATION ON PRIVATE PROPERTY  
SCALE: N.T.S.

**NOTES:**

1. TYPICALLY THE "A" AND "B" DUCTS WILL BE USED FOR MAIN PRIMARY DISTRIBUTION AND POINTED TOWARDS THE MAIN TRENCH ALIGNMENT IN THE BLVD. C/W BELL ENDS.
2. TYPICALLY THE "C" AND "D" DUCTS WILL BE RESERVED FOR FUTURE CUSTOMERS. STUB THE DUCTS 1000 mm INTO PRIVATE PROPERTY BEYOND THE URW C/W BELL ENDS TAPED, SANDED AND A MARKER BALL TO IDENTIFY THE END OF THE DUCT.

ALL DIMENSIONS IN MILLIMETERS ( INCHES ) UNLESS OTHERWISE SPECIFIED.

20170629 15:04 r lawrie

<b>VOLUME 7 - C.O.E. DESIGN &amp; CONSTRUCTION STANDARDS</b>	
REVIEWED BY STANDARDS COMMITTEE:	2017-05-26
DRAFTED BY:	R. LAWRIE
DESIGNED BY:	N. WELSH
SCALE:	N. T. S.
DATE REVISED:	2017-06-21



<b>TYPICAL PIPE LOCATIONS FOR 4-WAY SINGLE PHASE DEADFRONT SWITCHING CUBICLES ( ALL VARIANTS )</b>	
STANDARD NO.	PAGE NO.
66 00 07 00 23 114	1 / 3

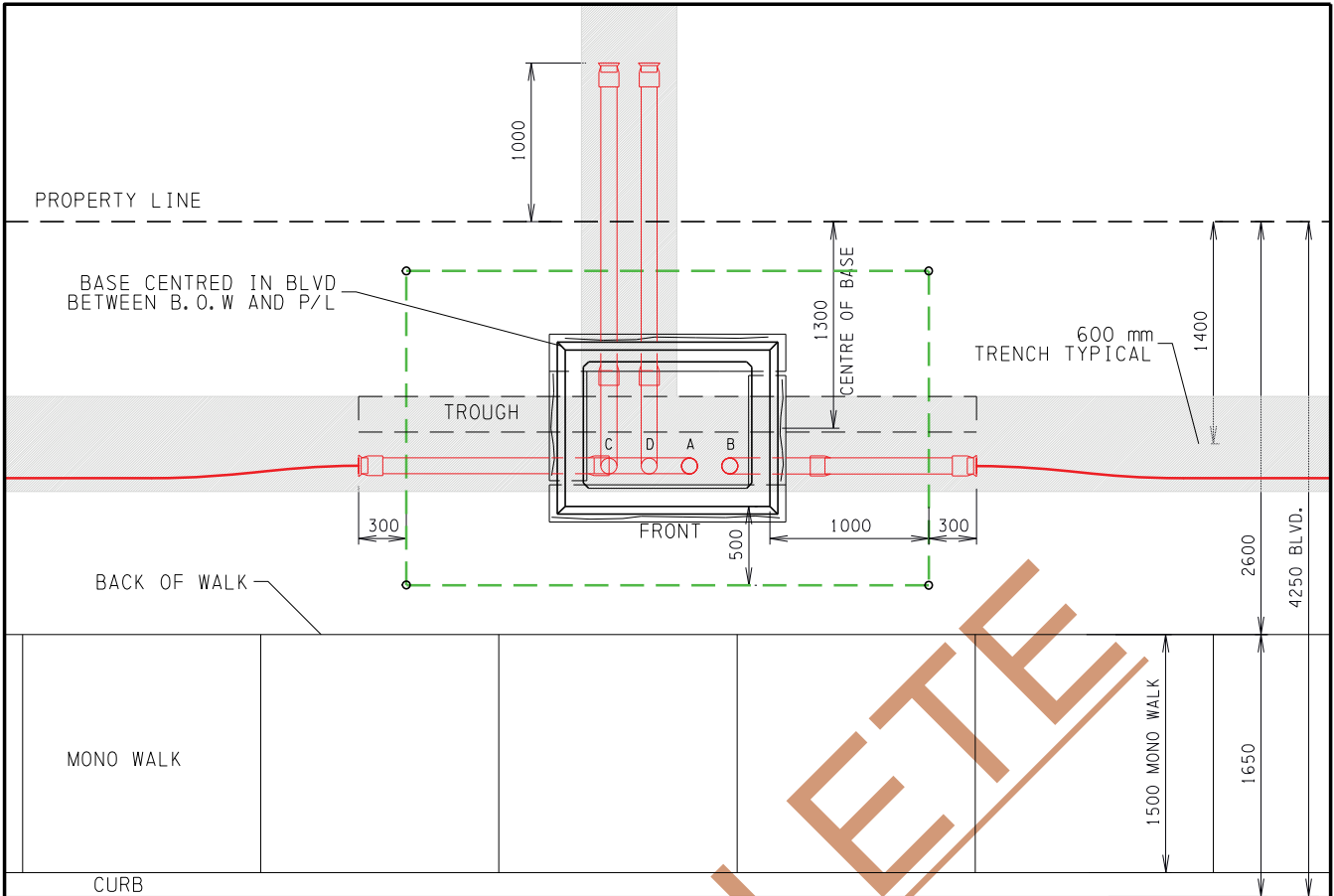

INSTALLATION IN BLVD WITH MONO WALK  
SCALE: N.T.S.

**NOTES:**

1. FOR EACH CROSS SECTION REFER TO THE CITY OF EDMONTON DESIGN & CONSTRUCTION STANDARDS VOLUME 2 TO CALCULATE THE ALIGNMENT OF THE BASE AND CLEARANCES OF GROUND GRIDS.
2. DO NOT INSTALL THE GROUND GRID UNDER A MONO WALK. LOCATE THE BASE FURTHER BACK OF WALK IN LARGER BLVDS.
3. TROUGH 300 mm PAST THE GROUND GRID. SEE 66 00 07 00 46 005 FOR TROUGHING DETAILS.
4. TYPICALLY THE "A" AND "B" DUCTS WILL BE USED FOR MAIN PRIMARY DISTRIBUTION AND POINTED TOWARDS THE MAIN LINE TRENCH IN THE BLVD. C/W BELL ENDS.
5. TYPICALLY THE "C" AND "D" DUCTS WILL BE RESERVED FOR FUTURE CUSTOMERS. STUB THESE DUCTS 1000 mm INTO PRIVATE PROPERTY C/W BELL ENDS TAPED, SANDED AND A MARKER BALL TO IDENTIFY THE END OF THE DUCTS.

ALL DIMENSIONS IN MILLIMETERS (INCHES) UNLESS OTHERWISE SPECIFIED.

VOLUME 7 - C.O.E.  
DESIGN & CONSTRUCTION  
STANDARDS

REVIEWED BY STANDARDS  
COMMITTEE: 2017-05-26

DRAFTED BY: R. LAWRIE

DESIGNED BY: N. WELSH

SCALE: N. T. S.

DATE REVISED: 2017-06-21



TYPICAL PIPE LOCATIONS  
FOR 4-WAY SINGLE PHASE  
DEADFRONT SWITCHING CUBICLES  
(ALL VARIANTS)

STANDARD NO.

66 00 07 00 23 114

PAGE NO.

2 / 3

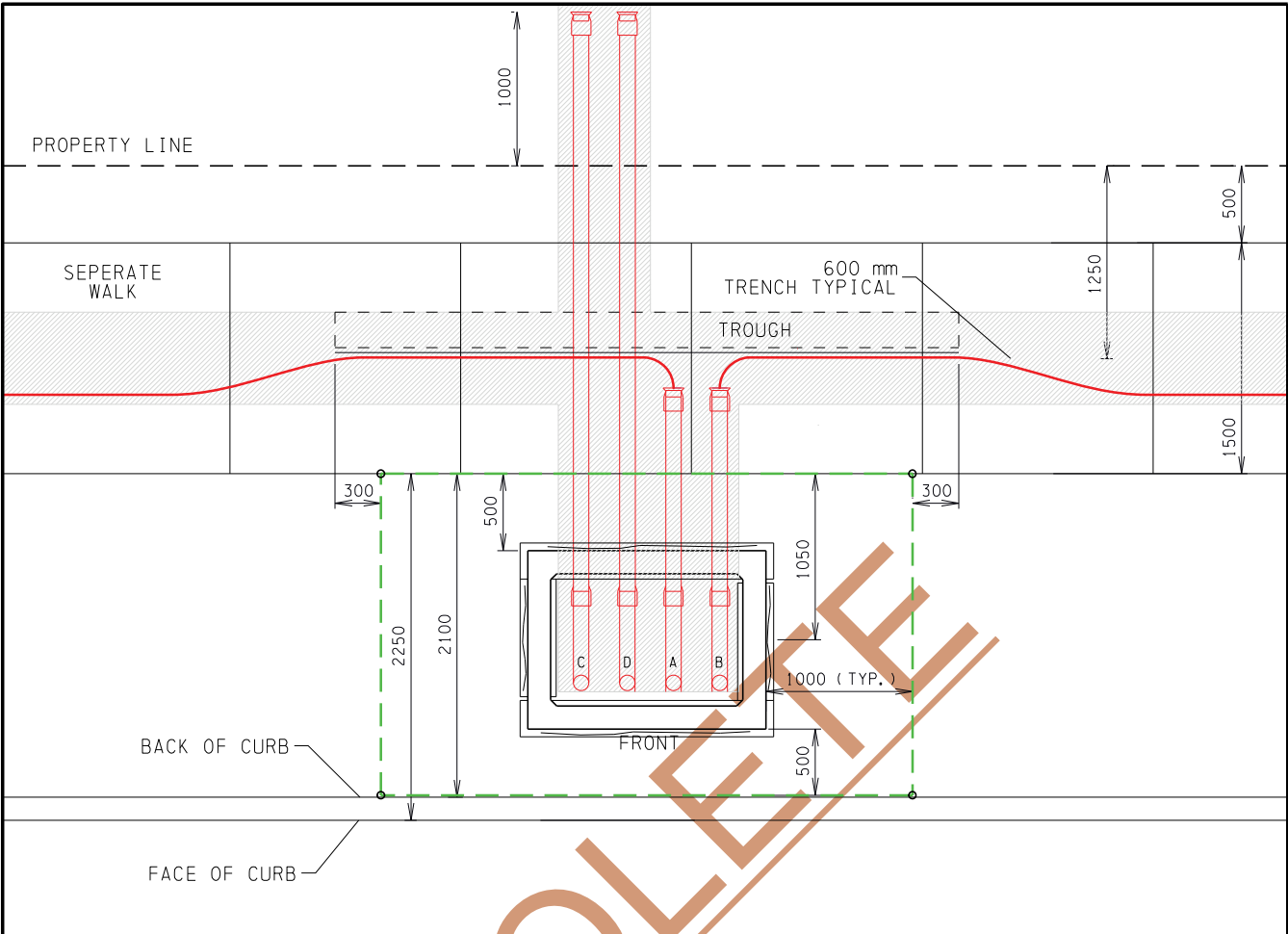

BLVD INSTALLATION WITH SEPARATE WALK  
SCALE: N. T. S.

**NOTES:**

1. FOR EACH CROSS SECTION REFER TO THE CITY OF EDMONTON DESIGN & CONSTRUCTION STANDARDS VOLUME 2 TO CALCULATE THE ALIGNMENT OF THE BASE AND CLEARANCES OF GROUND GRIDS.
2. THE GROUND GRID CANNOT BE INSTALLED UNDER THE SEPARATE WALK.
3. FOR LARGER BLVDs, ALIGN EDGE OF BASE WITH OTHER FURNITURE (I. E. TREES, HYDRANTS STREET LIGHT SETBACKS).
4. TROUGH 300 mm PAST THE GROUND GRID. SEE STANDARD 66 00 07 00 46 005 FOR TROUGHING DETAILS.
5. TYPICALLY THE "A" AND "B" DUCTS WILL BE USED FOR MAIN PRIMARY DISTRIBUTION AND POINTED TOWARDS THE MAIN TRENCH ALGINMENT IN THE BLVD. C/W BELL ENDS.
6. TYPICALLY THE "C" AND "D" DUCTS WILL BE RESERVED FOR FUTURE CUSTOMERS. STUB THESE DUCTS 1000 mm INTO PRIVATE PROPERTY C/W BELL ENDS TAPED, SANDED AND A MARKER BALL TO IDENTIFY THE END OF THE DUCTS.

ALL DIMENSIONS IN MILLIMETERS ( INCHES ) UNLESS OTHERWISE SPECIFIED.

**VOLUME 7 - C.O.E.  
DESIGN & CONSTRUCTION  
STANDARDS**

REVIEWED BY STANDARDS  
COMMITTEE: 2017-05-26

DRAFTED BY: R. LAWRIE

DESIGNED BY: N. WELSH

SCALE: N. T. S.

DATE REVISED: 2017-06-21



**TYPICAL PIPE LOCATIONS  
FOR 4-WAY SINGLE PHASE  
DEADFRONT SWITCHING CUBICLES  
( ALL VARIANTS )**

STANDARD NO.

**66 00 07 00 23 114**

PAGE NO.

3 / 3

20170629 15:05 r lawrie

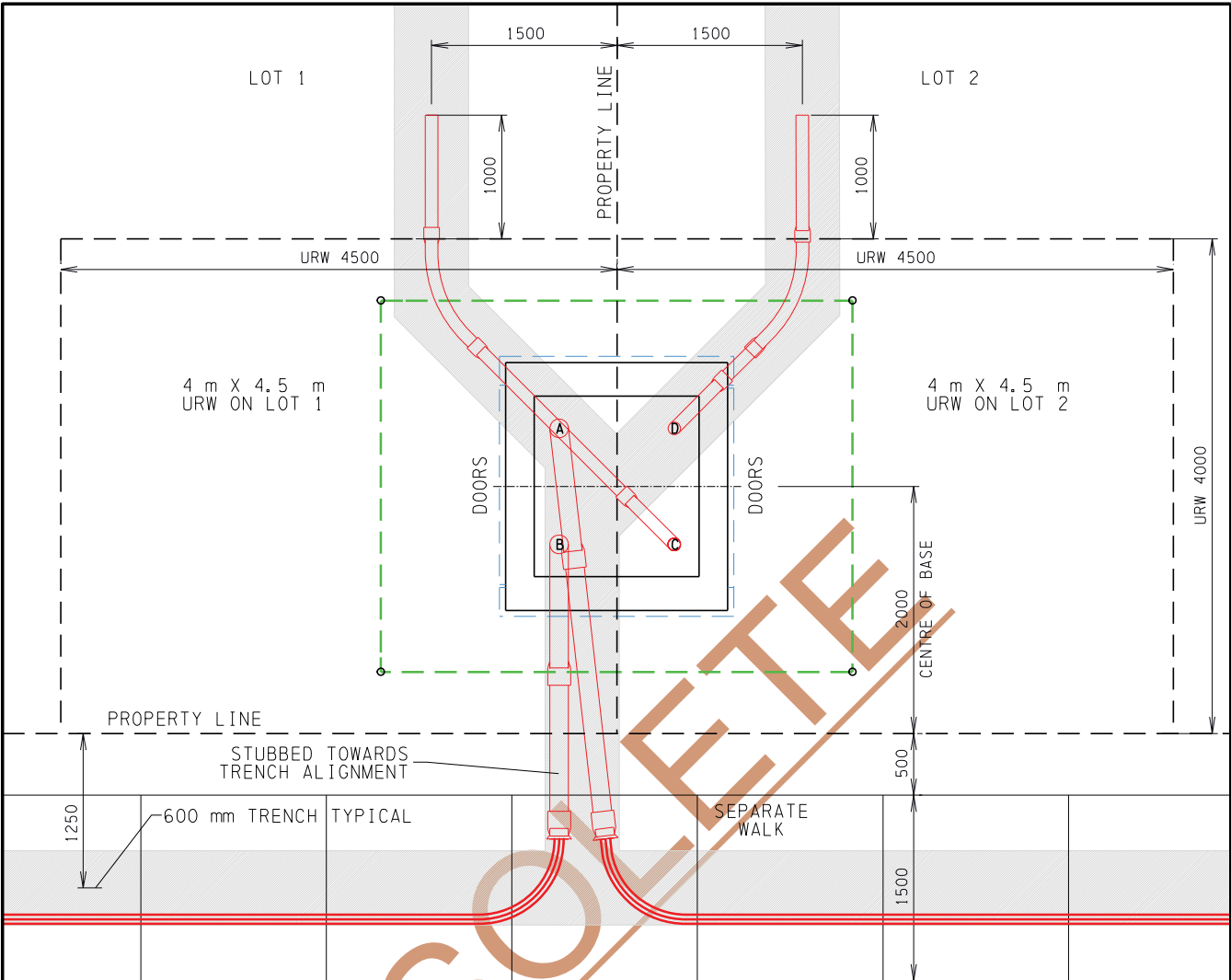

URW INSTALLATION ON PRIVATE PROPERTY  
SCALE: N.T.S.

**NOTES:**

1. TYPICALLY THE "A" AND "B" DUCTS WILL BE USED FOR MAIN PRIMARY DISTRIBUTION AND POINTED TOWARDS THE MAIN TRENCH ALIGNMENT IN THE BLVD. C/W BELL ENDS. DEPENDING ON THE APPLICATION, ARRANGE THE "A" AND "B" DUCTS AVOIDING PRIMARY FROM CROSSING OVER IN THE MAIN TRENCH.
2. TYPICALLY THE "C" AND "D" DUCTS WILL BE RESERVED FOR FUTURE CUSTOMERS. STUB THE DUCTS 300 mm INTO PRIVATE PROPERTY BEYOND THE URW, ENDS TAPED, SANDED AND A MARKER BALL TO IDENTIFY THE END OF THE DUCT.

ALL DIMENSIONS IN MILLIMETERS ( INCHES ) UNLESS OTHERWISE SPECIFIED.

20170629 11:35 r lawrie

<b>VOLUME 7 - C.O.E. DESIGN &amp; CONSTRUCTION STANDARDS</b>	
REVIEWED BY STANDARDS COMMITTEE:	2017-05-26
DRAFTED BY:	R. LAWRIE
DESIGNED BY:	N. WELSH
SCALE:	N. T. S.
DATE REVISED:	2017-06-21



**TYPICAL PIPE LOCATIONS  
FOR 4-WAY 3 PHASE  
DEADFRONT SWITCHING CUBICLES  
( ALL VARIANTS )**

STANDARD NO. <b>65 00 07 00 23 132</b>	PAGE NO. 1 / 3
-------------------------------------------	-------------------

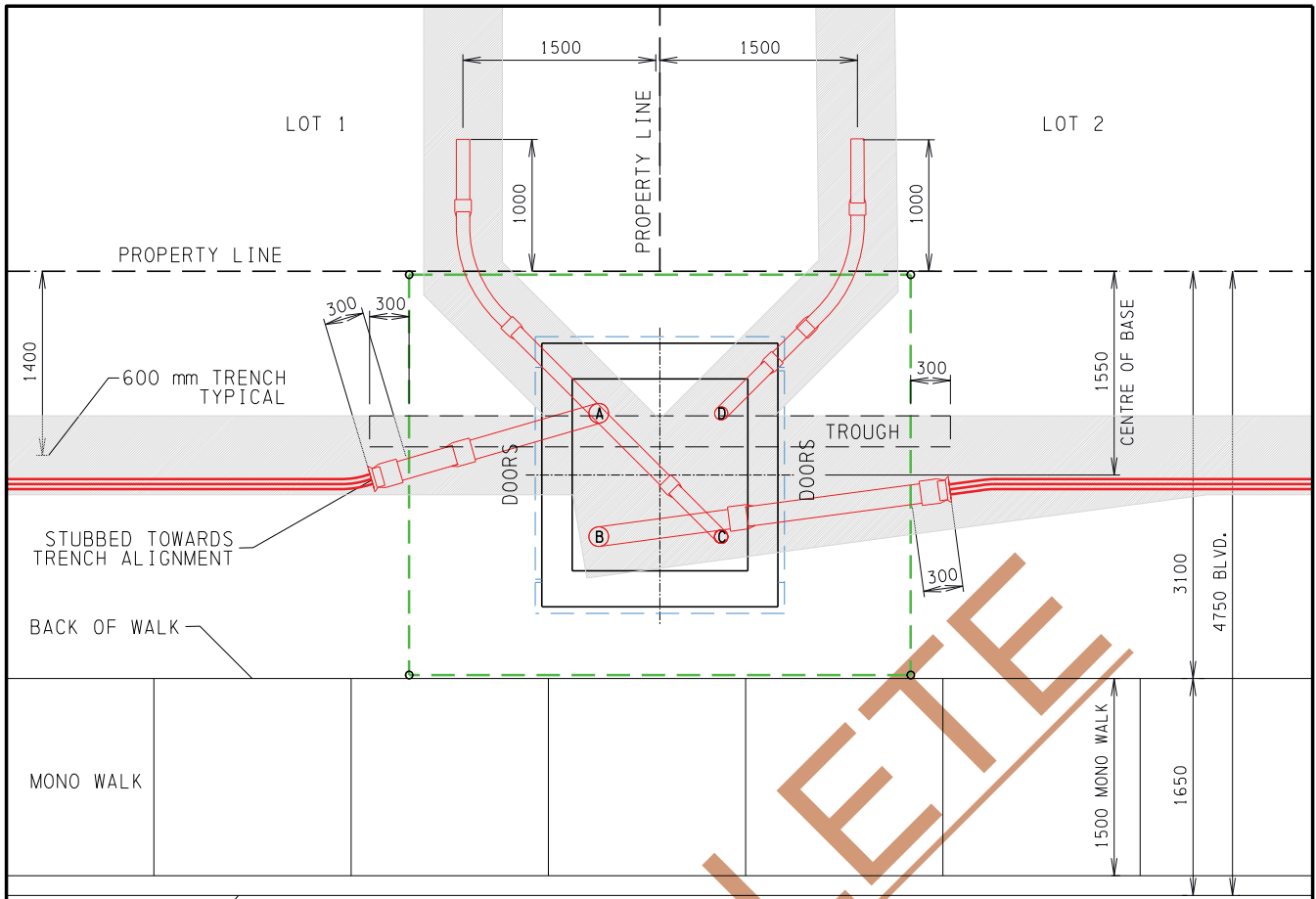

INSTALLATION IN BLVD WITH MONO WALK  
SCALE: N.T.S.

**NOTES:**

1. FOR EACH CROSS SECTION REFER TO THE CITY OF EDMONTON DESIGN & CONSTRUCTION STANDARDS VOLUME 2 TO CALCULATE THE ALIGNMENT OF THE BASE AND CLEARANCES OF GROUND GRIDS.
2. DO NOT INSTALL THE GROUND GRID UNDER A MONO WALK.
3. LOCATE THE BASE FURTHER FROM BACK OF WALK IN LARGER BLVDS.
4. TROUGH WILL EXTEND 300 mm PAST THE GROUND GRID, SEE STANDARD 66 00 07 00 46 005 FOR TROUGHING DETAILS.
5. TYPICALLY THE "A" AND "B" DUCTS WILL BE USED FOR MAIN PRIMARY DISTRIBUTION AND POINTED TOWARDS THE MAIN LINE TRENCH IN THE BLVD. C/W BELL ENDS.
6. TYPICALLY THE "C" AND "D" DUCTS WILL BE RESERVED FOR FUTURE CUSTOMERS. STUB THESE DUCTS 300 mm INTO PRIVATE PROPERTY, TAPED, SANDED AND A MARKER BALL TO IDENTIFY THE END OF THE DUCTS.

ALL DIMENSIONS IN MILLIMETERS (INCHES) UNLESS OTHERWISE SPECIFIED.

**VOLUME 7 - C.O.E.  
DESIGN & CONSTRUCTION  
STANDARDS**

REVIEWED BY STANDARDS  
COMMITTEE: 2017-05-26  
DRAFTED BY: R. LAWRIE  
DESIGNED BY: N. WELSH  
SCALE: N. T. S.  
DATE REVISED: 2017-06-21



**TYPICAL PIPE LOCATIONS  
FOR 4-WAY 3 PHASE  
DEADFRONT SWITCHING CUBICLES  
(ALL VARIANTS)**

STANDARD NO. **65 00 07 00 23 132** PAGE NO. 2 / 3

20170629 11:38 rlawrie

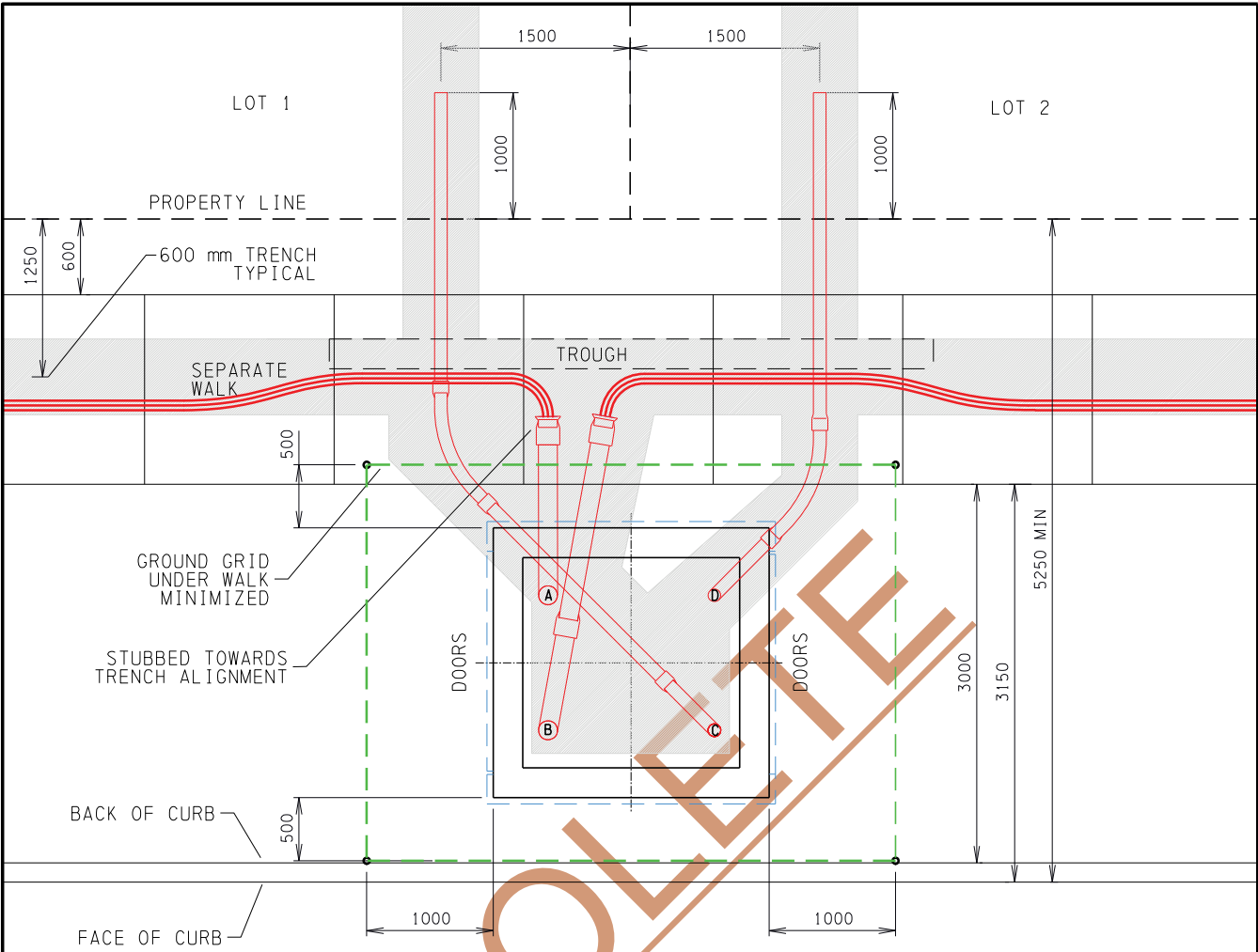

INSTALLATION IN BLVD WITH SEPARATE WALK  
SCALE: N.T.S.

**NOTES:**

1. FOR EACH CROSS SECTION FROM THE CITY OF EDMONTON DESIGN & CONSTRUCTION STANDARDS VOLUME 2, CALCULATE THE ALIGNMENT OF THE BASE AND CLEARANCES OF GROUND GRIDS.
2. IN CASES WHERE THE BLVD IS OF INSUFFICIENT DEPTH A MINIMUM OF THE GROUND GRID MAY BE INSTALLED UNDER THE SEPARATE WALK.
3. FOR LARGER BLVDS, ALIGN EDGE OF BASE WITH OTHER FURNITURE (I.E. TREES, HYDRANTS, STREET LIGHTS SET BACKS).
4. TROUGH 300 mm PAST THE GROUND GRID, SEE STANDARD 66 00 07 00 46 005 FOR TROUGHING DETAILS.
5. TYPICALLY THE "A" AND "B" DUCTS WILL BE USED FOR MAIN PRIMARY DISTRIBUTION AND POINTED TOWARDS THE MAIN TRENCH ALIGNMENT IN THE BLVD. C/W BELL ENDS.
6. TYPICALLY THE "C" AND "D" DUCTS WILL BE RESERVED FOR FUTURE CUSTOMERS. STUB THESE DUCTS 300 mm INTO PRIVATE PROPERTY, TAPED, SANDED AND A MARKER BALL TO IDENTIFY THE END OF THE DUCTS.

ALL DIMENSIONS IN MILLIMETERS ( INCHES ) UNLESS OTHERWISE SPECIFIED.

20170629 11:36 r lawrie

<b>VOLUME 7 - C.O.E.</b>	
<b>DESIGN &amp; CONSTRUCTION STANDARDS</b>	
REVIEWED BY STANDARDS COMMITTEE:	2017-05-26
DRAFTED BY:	R. LAWRIE
DESIGNED BY:	N. WELSH
SCALE:	N. T. S.
DATE REVISED:	2017-06-21



<b>TYPICAL PIPE LOCATIONS FOR 4-WAY 3 PHASE DEADFRONT SWITCHING CUBICLES ( ALL VARIANTS )</b>	
STANDARD NO.	PAGE NO.
65 00 07 00 23 132	3 / 3

# DEADFRONT 25 kV 600 A 4-WAY SWITCHING CUBICLES

25T462DD  
2 LB & 2 FDS

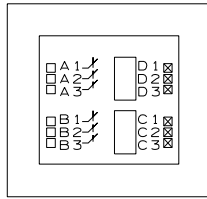

STK# 4943  
(PMSG-9)

25T464DD  
4 LB

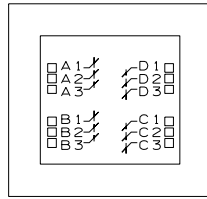

STK# 51223  
(PMSG-10)

25T463DD  
3 LB & 1 FDS

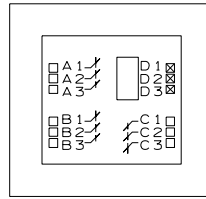

STK# 13252  
(PMSG-11)

25T461DD  
1 LB & 3 FDS

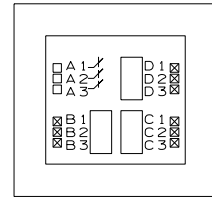

STK# 47628  
(PMSG-12)

1. FOR SWITCHING CUBICLE INSTALLATION SEE STANDARD 65 00 07 25 23 032.
2. FOR PRE-CAST BASE INSTALLATION SEE STANDARD 65 00 07 25 23 132.
3. USE "D2D" IN DEPARTMENT NUMBER FOR DOUBLE DEAD FRONT CUBICLES WITH 200 A BUSHING AND "MVI" FOR MOULDED VACUUM INTERRUPTER SWITCHING CUBICLES. EG. 25T422D2D OR 25T462MVI

# DEADFRONT 25 kV 200 A THREE PHASE 4-WAY

25T422DD  
PMSG-200-9

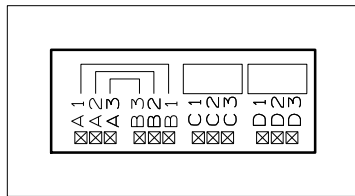

200 AMP DEADFRONT  
STOCK No. 66372

25T421DD  
PMSG-200-12

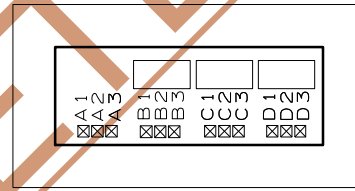

200 AMP DEADFRONT  
STOCK No. 6840

1. FOR SWITCHING CUBICLE INSTALLATION SEE STANDARD 66 00 07 25 23 035.
2. FOR PRE-CAST BASE INSTALLATION SEE STANDARD 65 00 07 25 23 132.

**NOTE:**

THE FAULT RATING OF THIS CUBICLE IS LIMITED BY THE RATING OF THE 200A ELBOW - 200A CONTINUOUS, 10KA SYMMETRICAL, 10 CYCLES.

# DEADFRONT 25 kV 200 A SINGLE PHASE 4-WAY

15S422DD  
PMSG-S4S

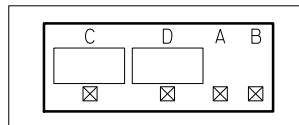

200 AMP DEADFRONT  
STOCK No. 44625

1. FOR SWITCHING CUBICLE INSTALLATION SEE STANDARD 66 00 07 25 23 014.
2. FOR PRE-CAST BASE INSTALLATION SEE STANDARD 66 00 07 25 23 114.

20170602 13:22 r lawrie

**VOLUME 7 - C.O.E.  
DESIGN & CONSTRUCTION  
STANDARDS**

REVIEWED BY STANDARDS  
COMMITTEE: 2014-04-08

DRAFTED BY: R. LAWRIE

DESIGNED BY: A. RAHMAN

SCALE: N. T. S.

DATE REVISED: 2016-03-01



**SUMMARY OF 25 kV  
DEAD FRONT SWITCHING CUBICLE  
SCHEMATIC INFORMATION**

STANDARD NO.  
**65 00 07 25 23 009**

PAGE NO.  
1 / 1



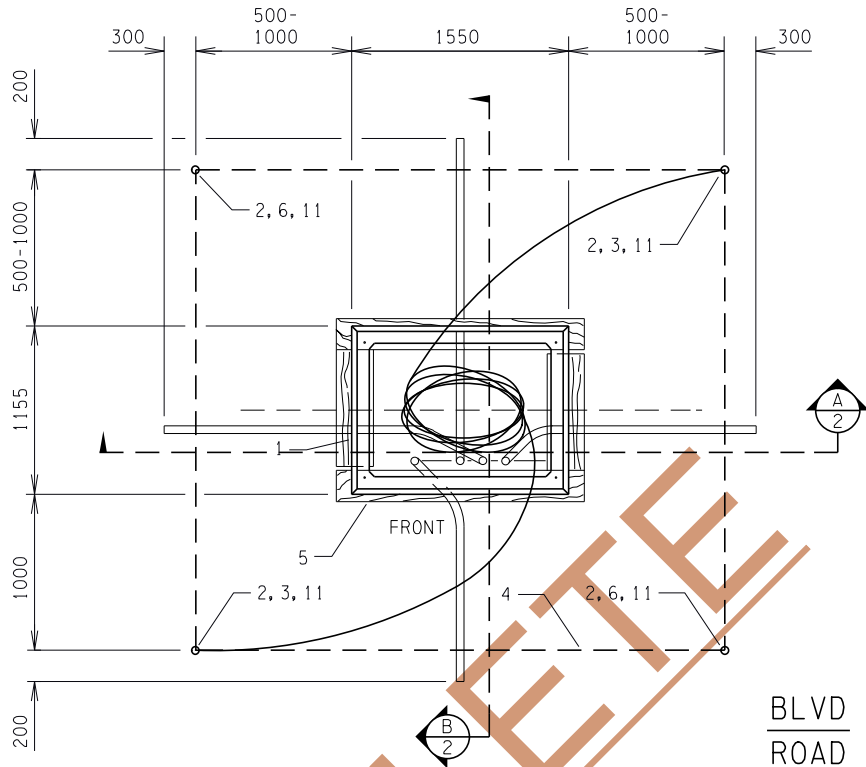

PLAN VIEW  
SCALE: N.T.S.

**NOTES:**

1. INTERCONNECTING GRADIENT CONTROL CONDUCTORS SHALL BE INSTALLED A MINIMUM OF 300 mm BELOW FINAL FINISHED GRADE (NOT ROUGH GRADE) WITH ONE LEG CONTINUOUS AROUND THE PERIMETER AND INTO THE BASE WITH AN ADDITIONAL CONTINUOUS CONDUCTOR TAIL ATTACHED FROM THE OPPOSITE CORNER.
2. USE FINE FILL CLAY BACKFILL AROUND GROUND GRID.
3. OBSERVE 250 mm MINIMUM AND 300 mm MAXIMUM REQUIREMENT FOR ELEVATION FROM TOP OF BASE TO FINAL FINISHED GRADE (NOT ROUGH GRADE).
4. CABLES ARE TO BE INSTALLED THROUGH DUCTS ONLY.
5. RETAIN 5.0 m OF COILED 4/0 CU FOR CONNECTION TO GROUND BUS.
6. THE DUCTING SHOULD BE INSTALLED SO THAT THE ENDS ARE POINTING DIRECTLY UPWARDS WITH THE TOP OF THE END BELL 200 mm ABOVE THE PLANKS/BASE BOTTOM. SPARE DUCTS TO BE CAPPED AND TAPED.
7. ADDITIONAL GROUND ROD MAY BE REQUIRED TO ACHIEVE A RESISTANCE OF 6 OHMS OR LESS.
8. FOR CABLE BYPASS TROUGH REQUIREMENTS AND INSTALLATION SEE DRAWING 66 00 07 00 46 005.
9. ALL CABLES TO HAVE A MINIMUM OF 5 m EXTRA CABLE COILED IN THE BASE MEASURED FROM THE TOP OF PIPE OR THE BASE ENTRY POINT.
10. MECHANICAL PROTECTION FOR PADMOUNTED EQUIPMENT SHALL BE CONSIDERED AS PER CSA C22.3 No. 7-15 CLAUSE 10.5.
11. THE BASE SHALL BE INSTALLED SUCH THAT THE TOP SURFACE IS LEVEL.
12. BASE WEIGHT: 1585 kg (3494 lbs).

ALL DIMENSIONS IN MILLIMETERS ( INCHES ) UNLESS OTHERWISE SPECIFIED.

<b>VOLUME 7 - C.O.E.</b> <b>DESIGN &amp; CONSTRUCTION</b> <b>STANDARDS</b>		<b>INSTALLATION OF PRECAST</b> <b>CONCRETE BASE FOR 4-WAY</b> <b>25 kV SINGLE PHASE 200 AMP</b> <b>DEADFRONT SWITCHING CUBICLE</b>	
REVIEWED BY STANDARDS COMMITTEE: 2017-05-26		STANDARD NO.	PAGE NO.
DRAFTED BY: R. LAWRIE		66 00 07 25 23 114	1 / 5
DESIGNED BY: A. RAHMAN			
SCALE: N. T. S. DATE REVISED: 2017-06-30			

20170705 13:51 r lawrie

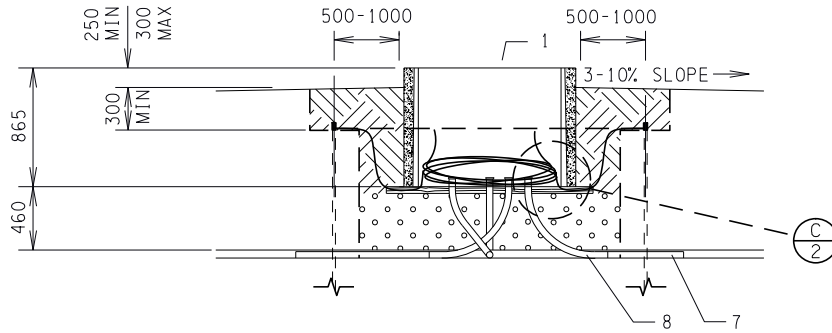

**(A) SECTION**  
SCALE: N.T.S.

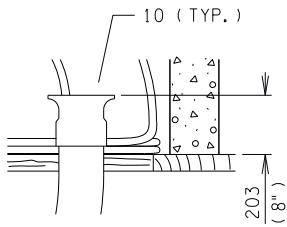

**(C) DETAIL**  
SCALE: N.T.S.

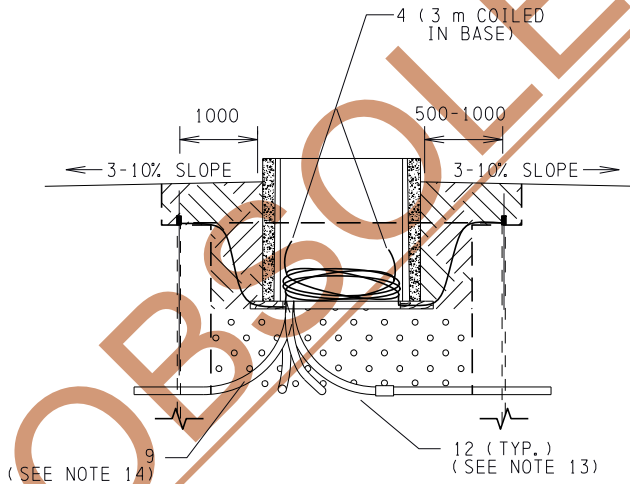

**(B) SECTION**  
SCALE: N.T.S.

**NOTES CONT'D:**

- 13. ADAPTER COUPLING IS REQUIRED FOR DB2 CONDUIT.
- 14. 36" RADIUS BENDS ARE PREFERRED FOR ALL DUCT BENDS.

ALL DIMENSIONS IN MILLIMETERS (INCHES) UNLESS OTHERWISE SPECIFIED.

**VOLUME 7 - C.O.E.  
DESIGN & CONSTRUCTION  
STANDARDS**

REVIEWED BY STANDARDS  
COMMITTEE: 2017-05-26  
DRAFTED BY: R. LAWRIE  
DESIGNED BY: A. RAHMAN  
SCALE: N. T. S.  
DATE REVISED: 2017-06-30



**INSTALLATION OF PRECAST  
CONCRETE BASE FOR 4-WAY  
25 kV SINGLE PHASE 200 AMP  
DEADFRONT SWITCHING CUBICLE**

STANDARD NO.  
**66 00 07 25 23 114**

PAGE NO.  
2 / 5

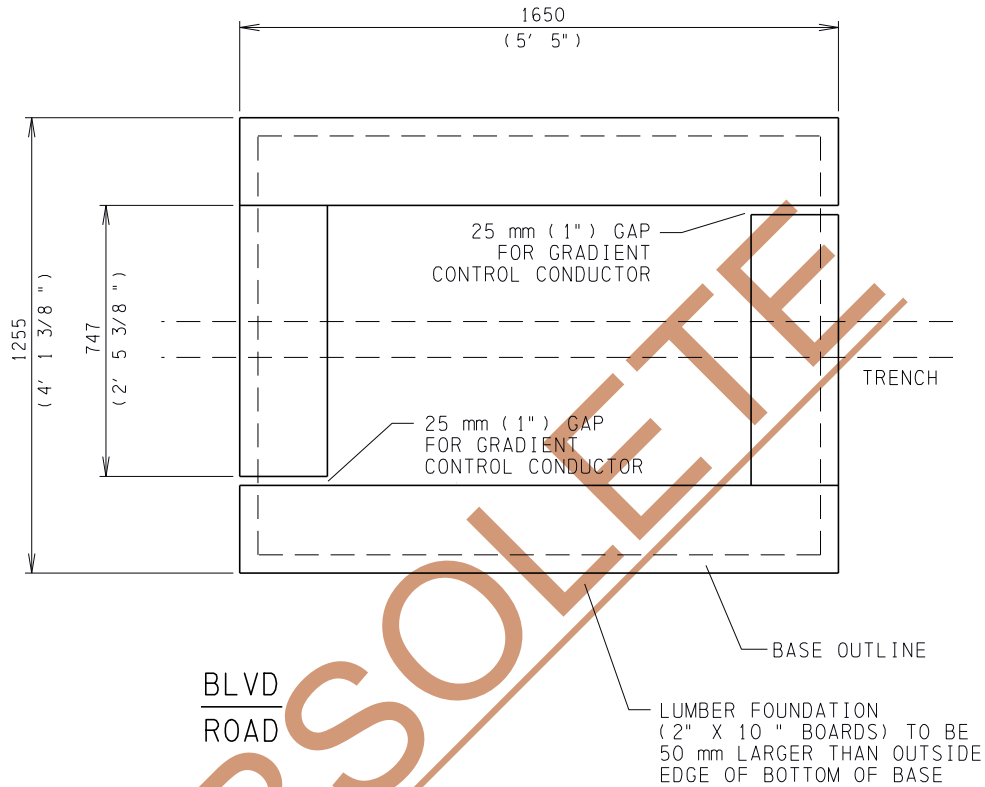

BLVD  
ROAD

LUMBER FOUNDATION  
SCALE: N.T.S.

NOTES CONT'D:

15. LUMBER FOUNDATION TO BE 2" x 10" PRESSURE TREATED SPRUCE WITH 2 - 1650 mm AND 2 - 747 mm LENGTHS (50 mm MAXIMUM LEDGE ON OUTSIDE).
16. RE-TREAT CUT ENDS OF LUMBER FOUNDATION BOARDS WITH COPPER NAPHTHANATE WOOD PRESERVATIVE.

ALL DIMENSIONS IN MILLIMETERS ( INCHES ) UNLESS OTHERWISE SPECIFIED.

VOLUME 7 - C.O.E.  
DESIGN & CONSTRUCTION  
STANDARDS

REVIEWED BY STANDARDS  
COMMITTEE: 2017-05-26

DRAFTED BY: R. LAWRIE

DESIGNED BY: A. RAHMAN

SCALE: N. T. S.

DATE REVISED: 2017-06-30



INSTALLATION OF PRECAST  
CONCRETE BASE FOR 4-WAY  
25 kV SINGLE PHASE 200 AMP  
DEADFRONT SWITCHING CUBICLE

STANDARD NO.

66 00 07 25 23 114

PAGE NO.

3 / 5

20170705 13:53 r lawrie

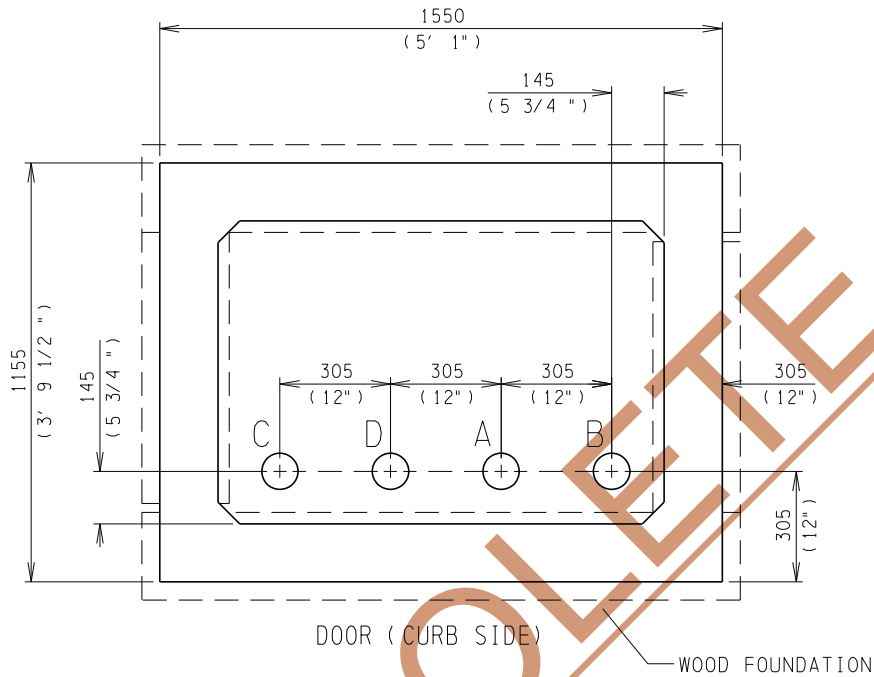

PIPE LOCATIONS  
SCALE: N.T.S.

BLVD  
ROAD

NOTES CONT'D:

- 17. ALL PIPES SHOULD BE DB2 OR RIGID PVC, BENDS TO BE RIGID PVC.
- 18. DUCT SIZES AS PER STANDARD 63 00 07 00 37 001.
- 19. ALL MEASUREMENTS ARE TO THE OUTSIDE "TOP" OF THE BASE.

ALL DIMENSIONS IN MILLIMETERS (INCHES) UNLESS OTHERWISE SPECIFIED.

VOLUME 7 - C.O.E.  
DESIGN & CONSTRUCTION  
STANDARDS



INSTALLATION OF PRECAST  
CONCRETE BASE FOR 4-WAY  
25 kV SINGLE PHASE 200 AMP  
DEADFRONT SWITCHING CUBICLE

REVIEWED BY STANDARDS COMMITTEE: 2017-05-26
DRAFTED BY: R. LAWRIE
DESIGNED BY: A. RAHMAN
SCALE: N. T. S.
DATE REVISED: 2017-06-30

STANDARD NO. 66 00 07 25 23 114	PAGE NO. 4 / 5
------------------------------------	-------------------

20170705 13:57 r.lawrie

ITEM	PART DESCRIPTION	STOCK No.	QTY.
1	BASE PRECAST 200 AMP 25 kV 4-WAY 1 PHASE DEADFRONT SWITCHING CUBICLE	56200	1
2	ROD GROUNDING 5/8" x 5'	17288	8
3	CONNECTOR GROUND ROD 3/4" - 250 DOUBLE WIRE	9136	2
4	WIRE #4/0 STRANDED COPPER BARE	45655	35
5	LUMBER SPRUCE PRESSURE-TREATED - 2" x 10" x 8' PWF (RE-TREAT CUT ENDS)	13235	2
6	CONNECTOR GROUND 3/4" ROD - 250 1/C	31914	2
7	PIPE DUCT 4"	AS REQ'D	A/R
	DB2 - 4"	53283	
	RIGID PVC - 4"	10083	
8	ROAD CRUSH - 3/4"	N/A	A/R
9	BEND RIGID PVC	AS REQ'D	A/R
	4" 90 DEGREE 24" RADIUS PLAIN ENDS	44327	
	4" 90 DEGREE 36" RADIUS PLAIN ENDS	22960	
10	END BELL COLLAR - RIGID PVC - 4"	20574	A/R
11	COUPLER - GROUND ROD	17289	4
12	ADAPTER COUPLING 4" DB2 - 4" PVC/FRE	38916	A/R

OBSOLETE

20170705 13:54 r lawrie

<p><b>VOLUME 7 - C.O.E.</b> <b>DESIGN &amp; CONSTRUCTION</b> <b>STANDARDS</b></p>		<p><b>INSTALLATION OF PRECAST</b> <b>CONCRETE BASE FOR 4-WAY</b> <b>25 kV SINGLE PHASE 200 AMP</b> <b>DEADFRONT SWITCHING CUBICLE</b></p>
<p>REVIEWED BY STANDARDS COMMITTEE: 2017-05-26</p> <p>DRAFTED BY: R. LAWRIE</p> <p>DESIGNED BY: A. RAHMAN</p> <p>SCALE: N. T. S.</p> <p>DATE REVISED: 2017-06-30</p>	<p>STANDARD NO. <b>66 00 07 25 23 114</b></p>	<p>PAGE NO. 5 / 5</p>

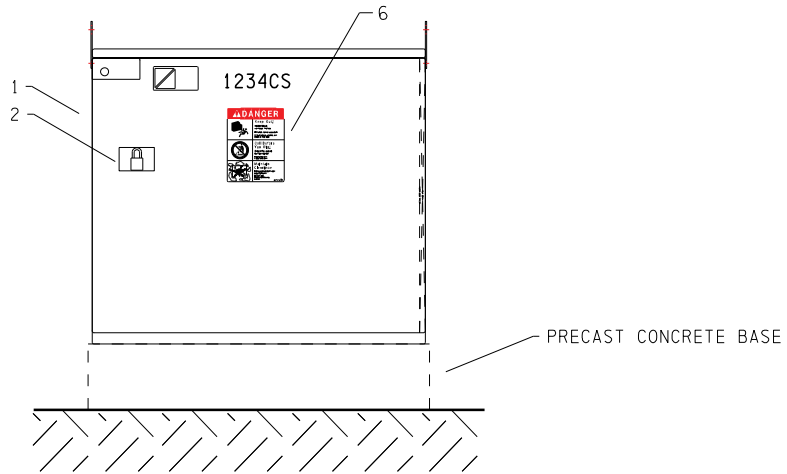

FRONT VIEW

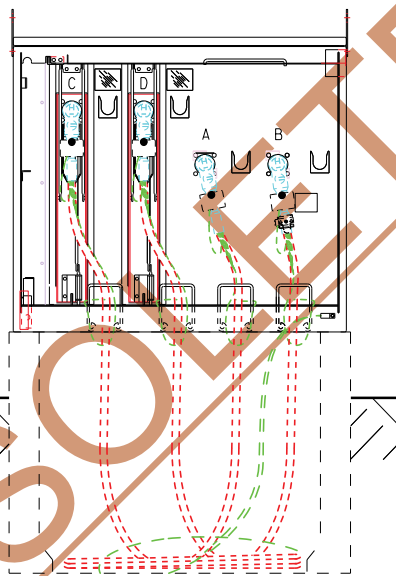

15S422DD\*\*\* (PMSG-SF4)  
FEED THROUGH & FUSE COMPARTMENT (C, D, A & B)

**NOTES:**

1. GROUNDING CONNECTION AND DETAILS SHOULD BE AS PER STANDARD 65 00 07 00 60 001.
2. PHYSICAL LOCATION OF FUSES ARE AS PER SCHEMATICS (SEE PAGE 2).
3. LOAD BREAK ELBOWS ARE TERMINATED AS PER STANDARD 63 00 07 00 48 006.
4. FUSE AS PER STANDARDS 60 00 07 25 50 010 AND 65 00 07 00 23 004.
5. FAULT INDICATORS TO BE INSTALLED ON THE "B" PRIMARY CABLE ONLY.
6. FOR ANCHOR DETAILS SEE STANDARD 65 00 07 00 23 003.
7. LIFTING EYES MUST BE ROTATED AND FACE DOWN.
8. ALL CABLES SHALL HAVE A MINIMUM OF 5 m OF EXTRA CABLE COILED IN THE BASE MEASURED FROM THE TOP OF PIPE OR BASE ENTRY POINT.
9. FOR PRECAST BASE INSTALLATION SEE 66 00 07 25 23 114.

20180628 11:05 jandrada



APEGGA PERMIT P7061

**UNDERGROUND**

**DISTRIBUTION STANDARDS**

REVIEWED BY STANDARDS  
COMMITTEE: 2013-02-12

DRAFTED BY: R. LAWRIE

DESIGNED BY: A. RAHMAN

SCALE: N. T. S.

DATE REVISED: 2018-06-28

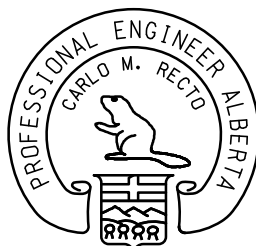

ORIGINAL SIGNED  
JUL. 21, 2016

**INSTALLATION OF 25kV  
4-WAY SINGLE PHASE 200 AMP  
DEADFRONT SWITCHING CUBICLE**

STANDARD NO.  
**66 00 07 25 23 014**

PAGE NO.  
1 / 3

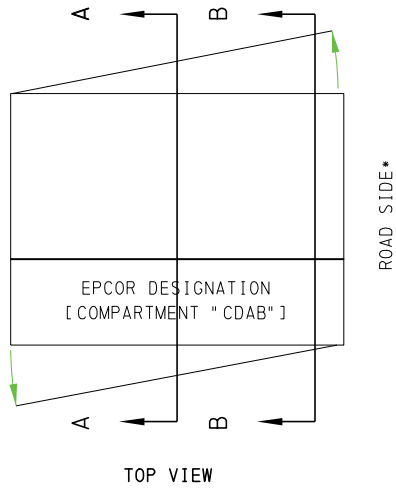

- \* PREFERRED CUBICLE ORIENTATION IS AS SHOWN WHENEVER POSSIBLE. ALTERNATE ORIENTATIONS ARE ACCEPTABLE UNDER CERTAIN DESIGN CONSTRAINTS.

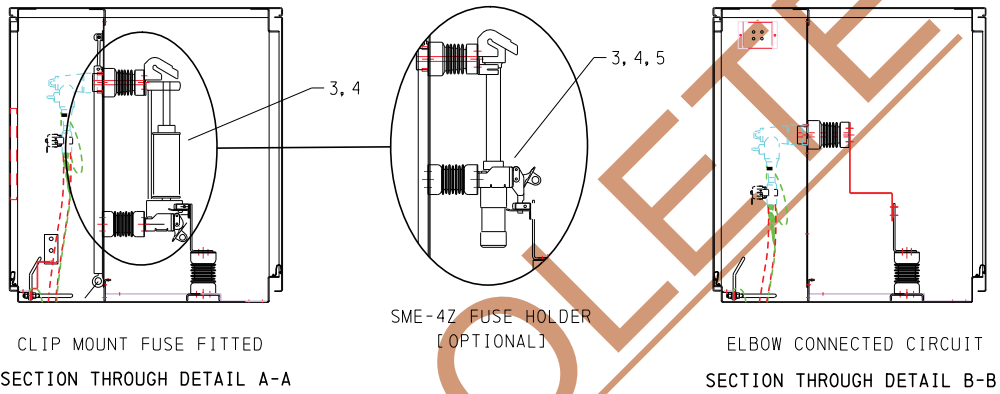

15S422DD\*\*\* (PMSG-SF4)

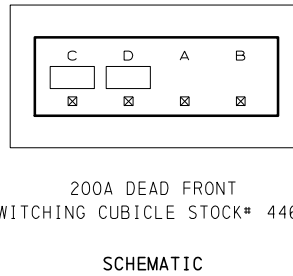
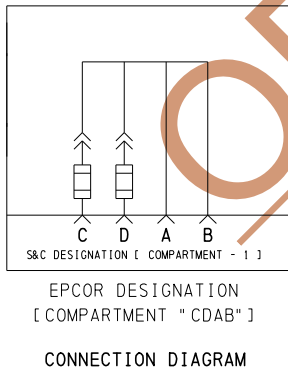

APEGGA PERMIT P7061

UNDERGROUND

DISTRIBUTION STANDARDS

REVIEWED BY STANDARDS  
COMMITTEE: 2013-02-12

DRAFTED BY: R. LAWRIE

DESIGNED BY: A. RAHMAN

SCALE: N. T. S.

DATE REVISED: 2018-06-28

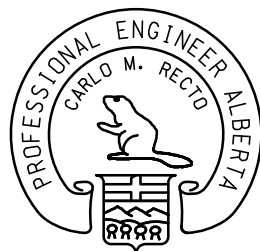

ORIGINAL SIGNED  
JUL. 21, 2016

INSTALLATION OF 25kV  
4-WAY SINGLE PHASE 200 AMP  
DEADFRONT SWITCHING CUBICLE

STANDARD NO.

66 00 07 25 23 014

PAGE NO.

2 / 3

20180628 11:06 jandraoda





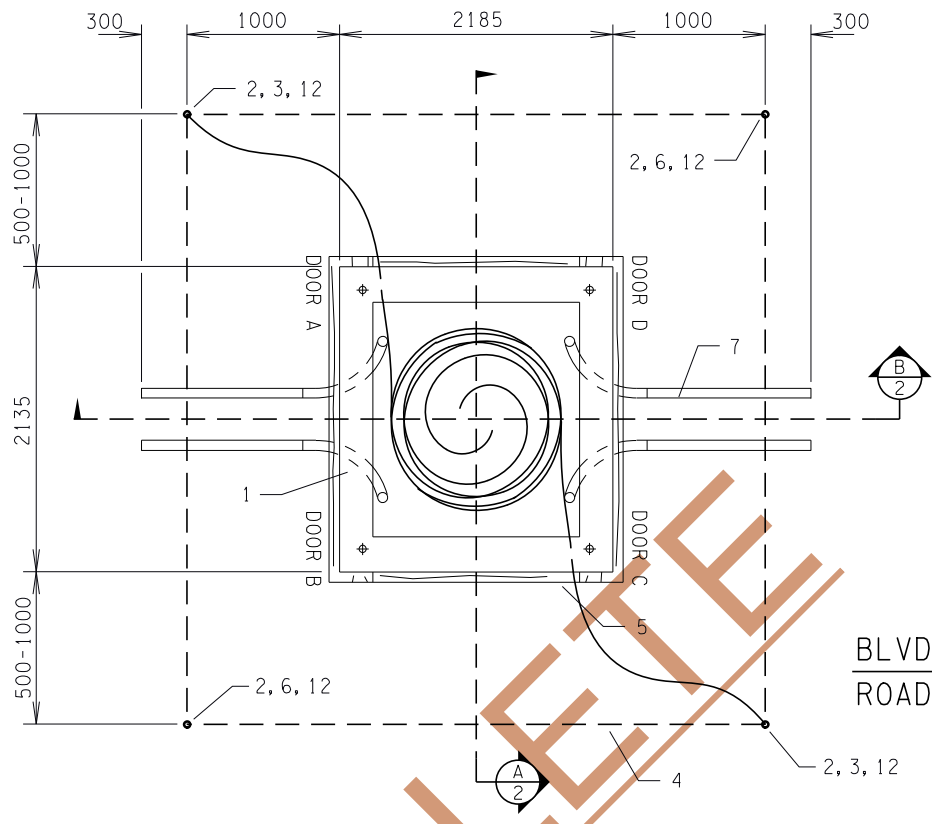

PLAN VIEW  
SCALE: N.T.S.

**NOTES:**

1. INTERCONNECTING GRADIENT CONTROL CONDUCTORS SHALL BE INSTALLED A MINIMUM OF 300 mm BELOW FINAL FINISHED GRADE (NOT ROUGH GRADE) WITH ONE LEG CONTINUOUS AROUND THE PERIMETER AND INTO THE BASE WITH AN ADDITIONAL CONTINUOUS CONDUCTOR TAIL ATTACHED FROM THE OPPOSITE CORNER.
2. USE FINE FILL CLAY BACKFILL AROUND GROUND GRID.
3. ENSURE TOP OF BASE IS BETWEEN 250 mm AND 300 mm FROM FINAL FINISHED GRADE (NOT ROUGH GRADE).
4. CABLES ARE TO BE INSTALLED THROUGH DUCTS ONLY.
5. RETAIN 5.0 m OF COILED 4/0 Cu FOR CONNECTION TO GROUND BUS.
6. PRIMARY CABLES ARE TO BE INSTALLED WITH 8 m COILED IN BASE PRIOR TO TERMINATION AND A MINIMUM OF ONE COMPLETE PERIMETER LOOP AFTER TERMINATION.
7. THE DUCTING SHOULD BE INSTALLED SO THAT THE ENDS ARE POINTING DIRECTLY UPWARDS WITH THE TOP OF THE END BELL 200 mm ABOVE THE PLANKS/BASE BOTTOM. SPARE DUCTS TO BE CAPPED AND TAPED.
8. ADDITIONAL GROUND ROD MAY BE REQUIRED TO ACHIEVE A RESISTANCE OF 6 OHMS OR LESS.
9. FOR CABLE BYPASS TROUGH REQUIREMENTS AND INSTALLATION SEE DRAWING 66 00 07 00 46 005.
10. THIS PRECAST BASE INSTALLATION STANDARD IS APPLICABLE FOR USE WITH THE FOLLOWING SWITCHING CUBICLE INSTALLATION STANDARDS: 65 00 07 25 23 030, 65 00 07 25 23 032, 65 00 07 25 23 037, 66 00 07 25 23 035.
11. MECHANICAL PROTECTION FOR PADMOUNTED EQUIPMENT SHALL BE CONSIDERED AS PER CSA C22.3 No. 7-15 CLAUSE 10.5.
12. THE BASE SHALL BE INSTALLED SUCH THAT THE TOP SURFACE IS LEVEL.
13. BASE WEIGHT: 2880 kg (6350 lbs).

ALL DIMENSIONS IN MILLIMETERS ( INCHES) UNLESS OTHERWISE SPECIFIED.

20170705 12:23 r lawrie

<b>VOLUME 7 - C.O.E.</b> <b>DESIGN &amp; CONSTRUCTION</b> <b>STANDARDS</b>		<b>INSTALLATION OF</b> <b>PRECAST CONCRETE BASE FOR</b> <b>4-WAY 3 PHASE 25 kV</b> <b>SWITCHING CUBICLE</b> <b>( ALL VARIANTS)</b>	
REVIEWED BY STANDARDS COMMITTEE: 2017-05-26		STANDARD NO.	PAGE NO.
DRAFTED BY: R. LAWRIE		<b>65 00 07 25 23 132</b>	1 / 6
DESIGNED BY: M. MIX			
SCALE: N. T. S. DATE REVISED: 2017-06-30			

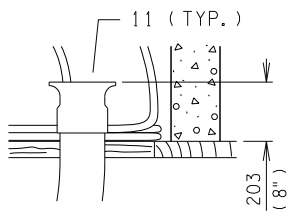
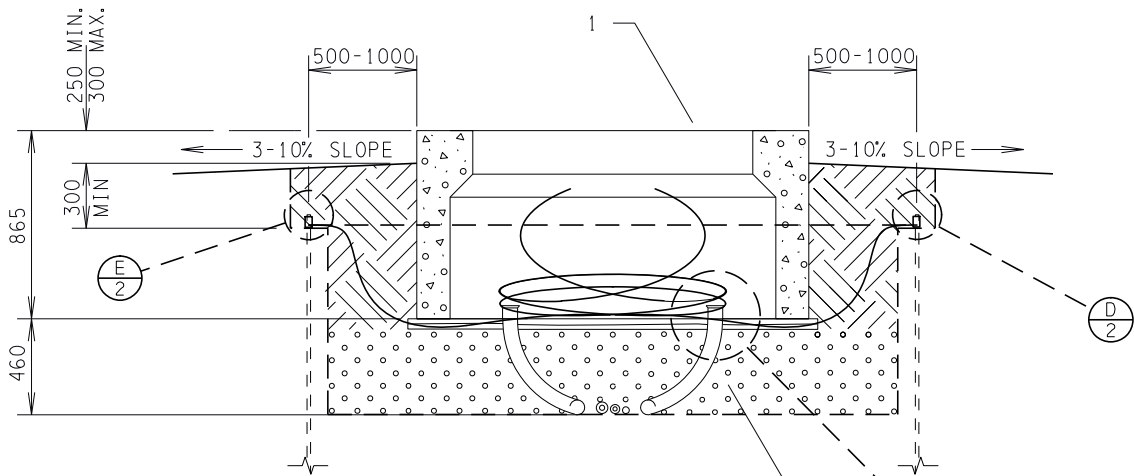

**C** DETAIL  
SCALE: N.T.S.

**A** SECTION  
SCALE: N.T.S.

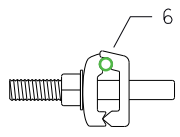

**E** 1/C CONNECTOR  
SCALE: N.T.S.

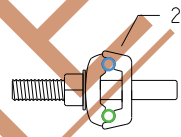

**D** 2/C CONNECTOR  
SCALE: N.T.S.

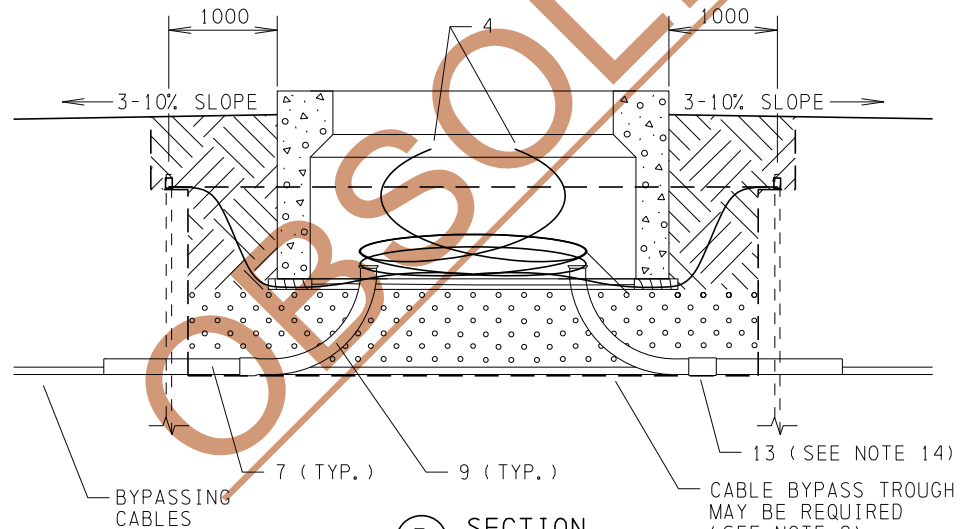

**B** SECTION  
SCALE: N.T.S.

13 (SEE NOTE 14)  
CABLE BYPASS TROUGH  
MAY BE REQUIRED  
(SEE NOTE 9)

**NOTES CONT'D:**

- 14. ADAPTER COUPLING IS REQUIRED FOR DB2 CONDUIT.
- 15. 36" RADIUS BENDS ARE PREFERRED FOR ALL DUCT BENDS.

ALL DIMENSIONS IN MILLIMETERS (INCHES) UNLESS OTHERWISE SPECIFIED.

<b>VOLUME 7 - C.O.E. DESIGN &amp; CONSTRUCTION STANDARDS</b>	
REVIEWED BY STANDARDS COMMITTEE:	2017-05-26
DRAFTED BY:	R. LAWRIE
DESIGNED BY:	M. MIX
SCALE:	N. T. S.
DATE REVISED:	2017-06-30



**INSTALLATION OF  
PRECAST CONCRETE BASE FOR  
4-WAY 3 PHASE 25 KV  
SWITCHING CUBICLE  
(ALL VARIANTS)**

STANDARD NO. <b>65 00 07 25 23 132</b>	PAGE NO. 2 / 6
-------------------------------------------	-------------------

20170705 12:34 r lawrie

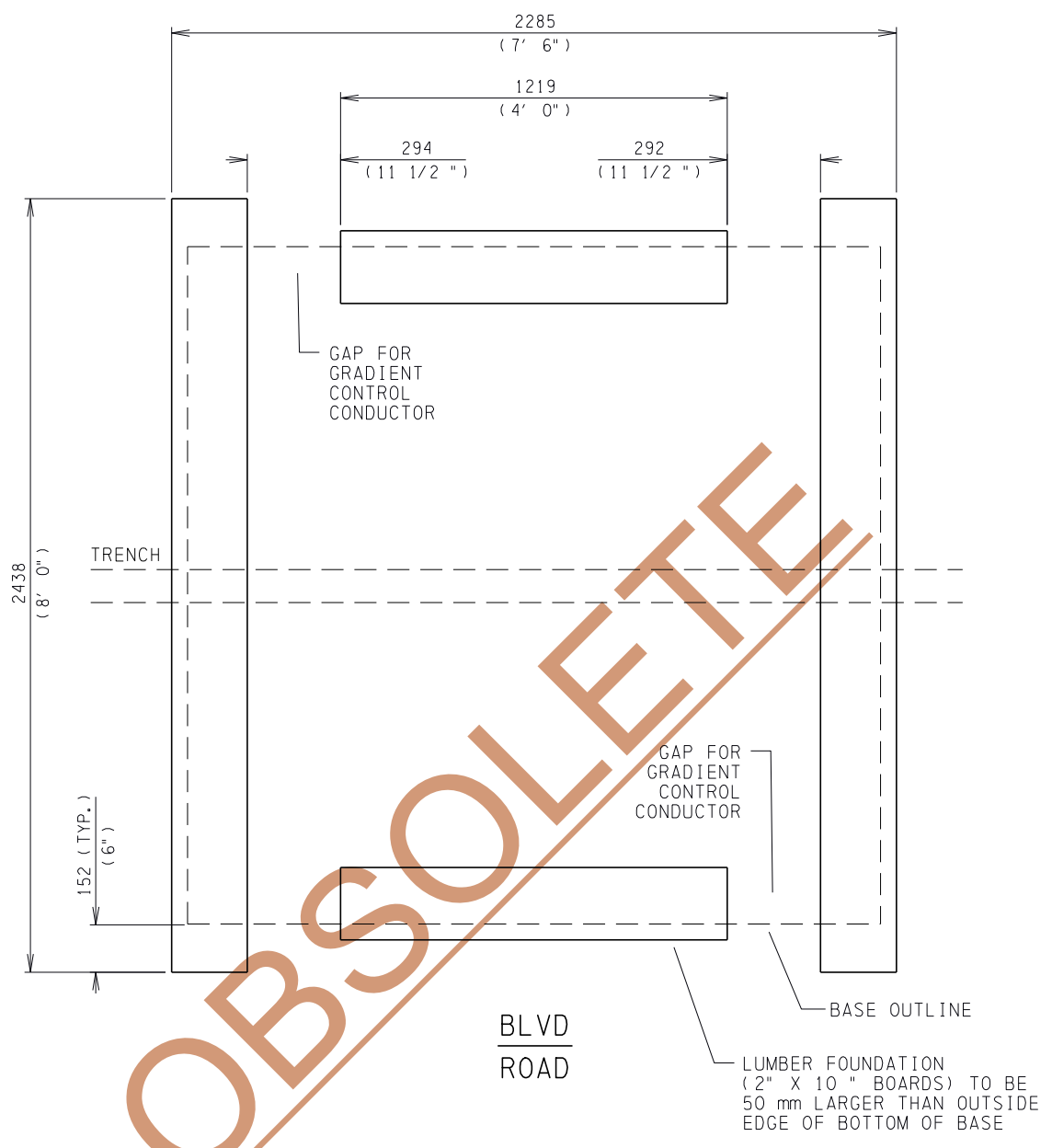

LUMBER FOUNDATION  
SCALE: N.T.S.

NOTES CONT'D:

- 16. LUMBER FOUNDATION SHOULD BE 2" x 10" PRESSURE TREATED SPRUCE WITH 2 - 2438 mm AND 2 - 1219 mm LENGTHS (50 mm MAXIMUM LEDGE ON OUTSIDE).
- 17. RE-TREAT CUT ENDS OF LUMBER FOUNDATION BOARDS WITH COPPER NAPHTHANATE WOOD PRESERVATIVE.

ALL DIMENSIONS IN MILLIMETERS ( INCHES ) UNLESS OTHERWISE SPECIFIED.

20170705 12:24 r lawrie

<b>VOLUME 7 - C.O.E.</b> <b>DESIGN &amp; CONSTRUCTION</b> <b>STANDARDS</b>		<b>INSTALLATION OF</b> <b>PRECAST CONCRETE BASE FOR</b> <b>4-WAY 3 PHASE 25 KV</b> <b>SWITCHING CUBICLE</b> <b>( ALL VARIANTS )</b>	
REVIEWED BY STANDARDS COMMITTEE: 2017-05-26		STANDARD NO.	PAGE NO.
DRAFTED BY: R. LAWRIE		<b>65 00 07 25 23 132</b>	<b>3 / 6</b>
DESIGNED BY: M. MIX			
SCALE: N. T. S.			
DATE REVISED: 2017-06-30			

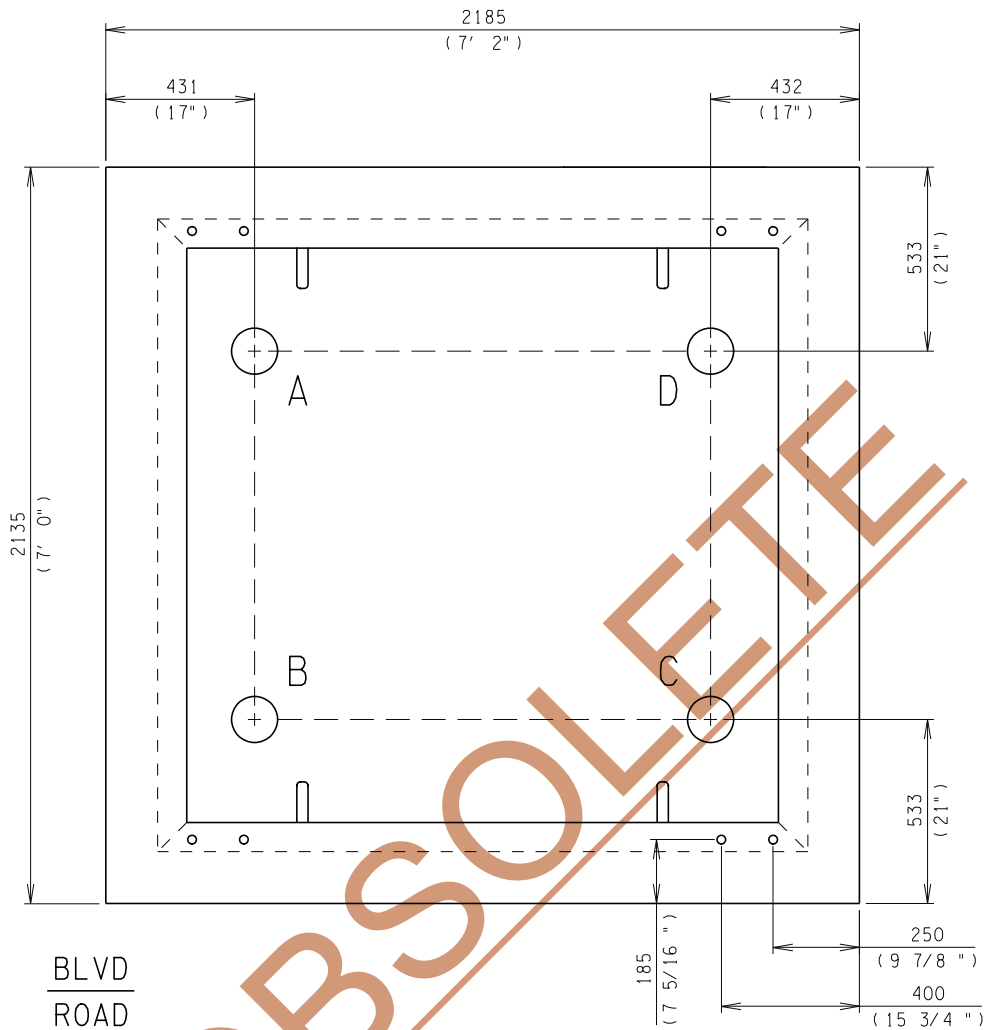

PIPE LOCATIONS  
SCALE: N.T.S.

NOTES CONT'D:

- 18. ALL PIPES SHOULD BE DB2 OR RIGID PVC, BENDS TO BE RIGID PVC.
- 19. DUCT SIZES AS PER STANDARD 63 00 07 00 37 001.
- 20. ALL MEASUREMENTS ARE TO THE OUTSIDE "TOP" OF THE BASE.

ALL DIMENSIONS IN MILLIMETERS (INCHES) UNLESS OTHERWISE SPECIFIED.

VOLUME 7 - C.O.E.  
DESIGN & CONSTRUCTION  
STANDARDS

REVIEWED BY STANDARDS  
COMMITTEE: 2017-05-26

DRAFTED BY: R. LAWRIE

DESIGNED BY: M. MIX

SCALE: N. T. S.

DATE REVISED: 2017-06-30



INSTALLATION OF  
PRECAST CONCRETE BASE FOR  
4-WAY 3 PHASE 25 KV  
SWITCHING CUBICLE  
(ALL VARIANTS)

STANDARD NO.

65 00 07 25 23 132

PAGE NO.

4 / 6

FROM SWITCH  
COMPARTMENT

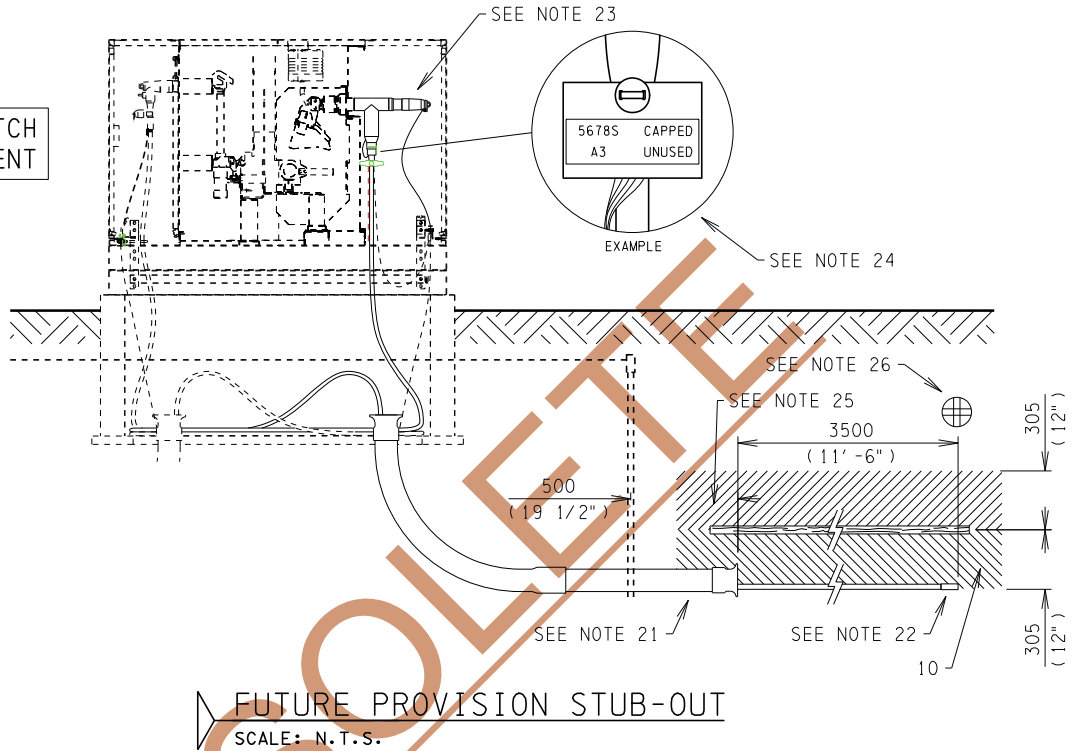

NOTES CONT'D:

21. FOR UNUSED COMPARTMENTS STUB OUT A CONDUIT 500 mm PAST THE GROUND GRID FOR FUTURE PROVISION.
22. ENSURE 3.5 m OF CABLE EXTENDS PAST THE END OF THE CONDUIT STUB OUT AND HEAT SHRINK THE CABLE TAIL AS PER 6600070048175.
23. FOR STUBBED CABLES ORIGINATING FROM SWITCH COMPARTMENTS THE ELBOWS ARE TO BE PLACED ON THE BUSHING WITH THE SWITCH IN THE OFF POSITION AND A LOCK & TAG ON THE SWITCH TO PREVENT OPERATION. THE CABLE NEUTRAL AND TERMINATION GROUND ARE TO BE CONNECTED TO THE GROUND BUS.
24. USE CABLE IDENTIFICATION TAG TO INDICATE THE TERMINATED CABLE AS UNUSED AND CAPPED. SEE STANDARD 6600070020001 FOR IDENTIFICATION TAG DETAILS.
25. EXPOSED CABLE TAILS NOT PROTECTED INSIDE CONDUIT OR UNDER A TEMPORARY CONCRETE BASE MUST BE COVERED BY THE FOLLOWING IN ORDER: A 300 mm THICK LAYER OF SAND, 2" x 8" (MINIMUM) PRESSURE TREATED PLANKING BUTTED TOGETHER WITHOUT VOIDS OR GAPS, AN ADDITIONAL 300 mm THICK LAYER OF SAND, AND FINALLY BACKFILLED TO GRADE AS PER SECTION A & B ON THIS DRAWING.
26. MARKER BALLS SHALL BE PLACED ABOVE THE CABLE TAIL ENDS. REFER TO STANDARD 6300070017001 OR A PRECAST BASE MAY BE USED AS PER STANDARD 66 00 07 00 48 100.

ALL DIMENSIONS IN MILLIMETERS ( INCHES ) UNLESS OTHERWISE SPECIFIED.

VOLUME 7 - C.O.E.  
DESIGN & CONSTRUCTION  
STANDARDS

REVIEWED BY STANDARDS  
COMMITTEE: 2017-05-26

DRAFTED BY: R. LAWRIE

DESIGNED BY: M. MIX

SCALE: N. T. S.

DATE REVISED: 2017-06-30



INSTALLATION OF  
PRECAST CONCRETE BASE FOR  
4-WAY 3 PHASE 25 KV  
SWITCHING CUBICLE  
( ALL VARIANTS )

STANDARD NO.  
65 00 07 25 23 132

PAGE NO.  
5 / 6

20170705 12:25 r lawrie

ITEM	PART DESCRIPTION	STOCK No.	QTY.
1	BASE PRECAST 600 AMP 25 KV 4-WAY 3 PHASE DEADFRONT SWITCHING CUBICLE	17253	1
2	ROD GROUNDING 5/8" x 5' (SEE NOTE 8)	17288	8
3	CONNECTOR GROUND ROD 3/4" - 250 DOUBLE WIRE	9136	2
4	WIRE #4/0 STRANDED COPPER BARE	45655	36m
5	LUMBER SPRUCE PRESSURE-TREATED - 2" x 10" x 8' PWF (RE-TREAT CUT ENDS)	13235	3
6	CONNECTOR GROUND 3/4" ROD - 250 1/C	31914	2
7	PIPE DUCT	AS REQ' D	A/R
	DB2 - 4"	53283	
	DB2 - 6"	42236	
	RIGID PVC - 4"	10083	
	RIGID PVC - 6"	10692	
8	ROAD CRUSH - 3/4"	N/A	A/R
9	BENDS RIGID PVC	AS REQ' D	4
	4" - 90 DEGREE 24" RADIUS PLAIN ENDS	44327	
	4" - 90 DEGREE 36" RADIUS PLAIN ENDS	22960	
	6" - 90 DEGREE 36" RADIUS PLAIN ENDS	17787	
10	SAND	N/A	A/R
11	END BELL COLLAR	AS REQ' D	A/R
	RIGID PVC - 4"	20574	
	RIGID PVC - 6"	20889	
12	COUPLER - GROUND ROD	17289	4
13	COUPLING ADAPTER	AS REQ' D	A/R
	4" DB2 TO 4" PVC	38916	
	6" DB2 TO 6" PVC	10284	

OBSOLETE

20170705 12:36 r lawrie

<b>VOLUME 7 - C.O.E.</b> <b>DESIGN &amp; CONSTRUCTION</b> <b>STANDARDS</b>		<b>INSTALLATION OF</b> <b>PRECAST CONCRETE BASE FOR</b> <b>4-WAY 3 PHASE 25 KV</b> <b>SWITCHING CUBICLE</b> <b>(ALL VARIANTS)</b>
REVIEWED BY STANDARDS COMMITTEE: 2017-05-26		
DRAFTED BY: R. LAWRIE		
DESIGNED BY: M. MIX		
SCALE: N. T. S.		
DATE REVISED: 2017-06-30	STANDARD NO. <span style="color: green;">65 00 07 25 23 132</span>	PAGE NO. 6 / 6

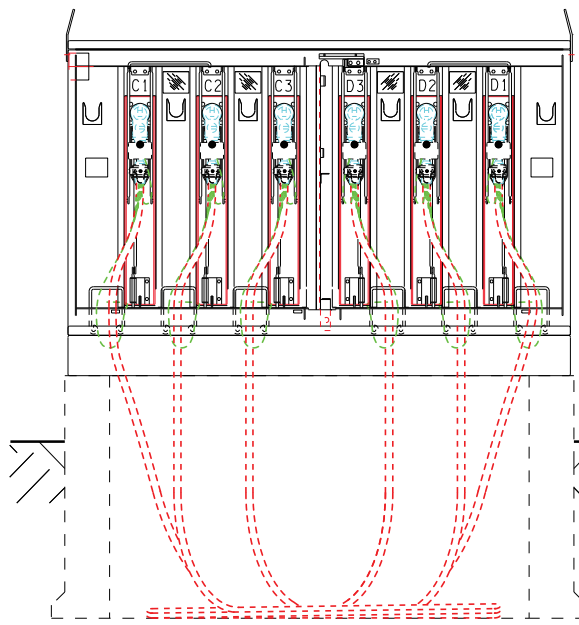

25T422DD\*\*\* (MSG-200-9) & 25T421DD\*\*\* (MSG-200-12)  
FUSE COMPARTMENT ( C & D )

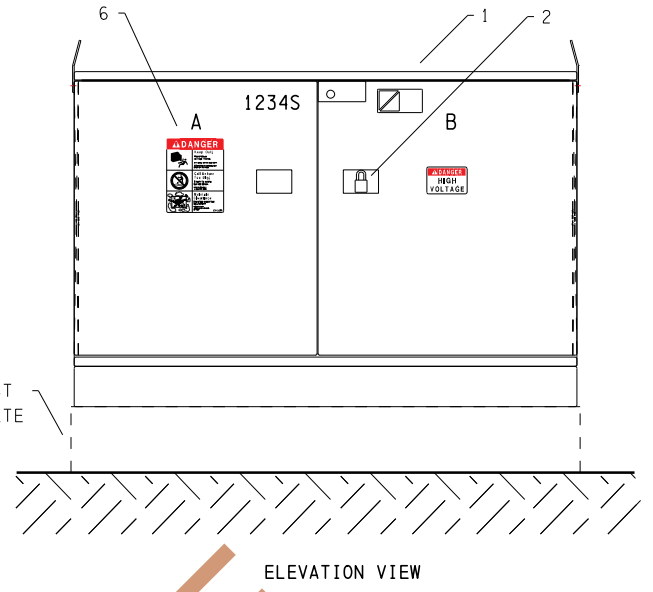

ELEVATION VIEW

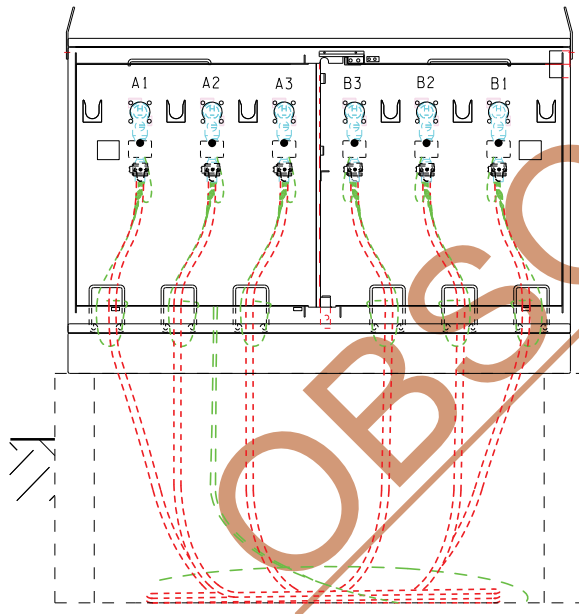

25T422DD\*\*\* (MSG-200-9)  
FEED THROUGH COMPARTMENT ( A & B )

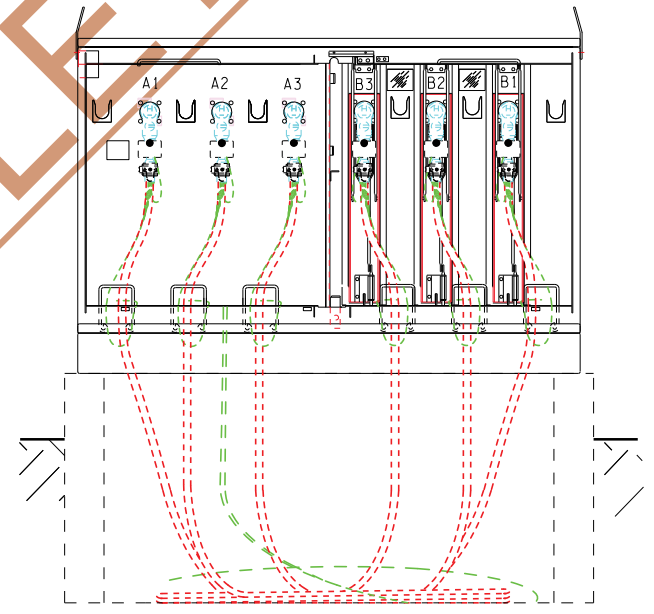

25T421DD\*\*\* (MSG-200-12)  
FEED THROUGH & FUSE COMPARTMENT ( A & B )

20180628 11:09 jandrada

 APEGGA PERMIT P7061 <b>UNDERGROUND</b> <b>DISTRIBUTION STANDARDS</b>	
REVIEWED BY STANDARDS COMMITTEE:	2013-02-12
DRAFTED BY:	R. LAWRIE
DESIGNED BY:	A. RAHMAN
SCALE:	N. T. S.
DATE REVISED:	2018-06-28

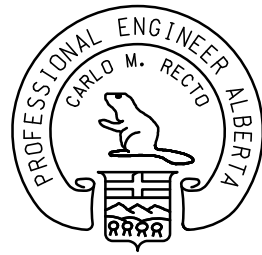

ORIGINAL SIGNED  
DEC. 29, 2016

<b>INSTALLATION OF 25 kV 4-WAY 3 PHASE 200 AMP DEADFRONT SWITCHING CUBICLE</b>	
STANDARD NO.	PAGE NO.
66 00 07 25 23 035	1 / 4

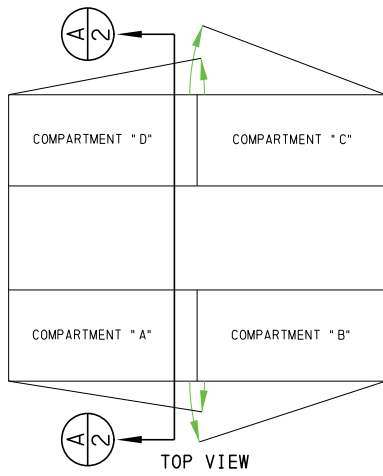

ROAD SIDE

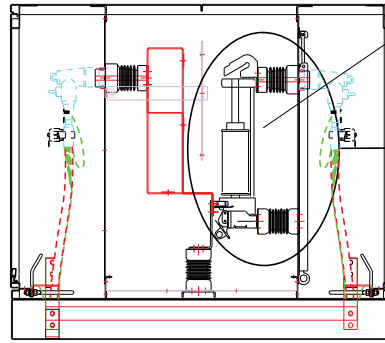

CLIP MOUNT FUSE FITTED  
SECTION THROUGH DETAIL A-A

SME-4Z FUSE HOLDER  
[ OPTIONAL ]

**25T422DD\*\*\* ( PMSG-200-9 )**

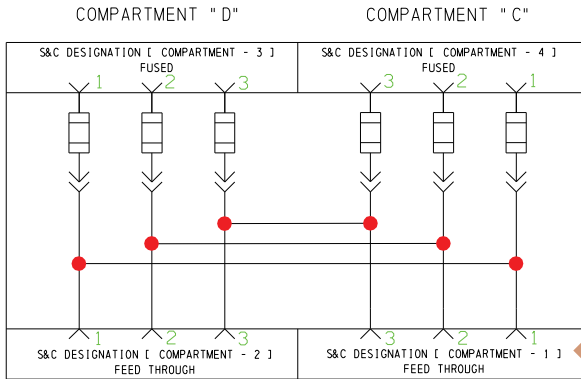

COMPARTMENT "A" COMPARTMENT "B"  
CONNECTION DIAGRAM

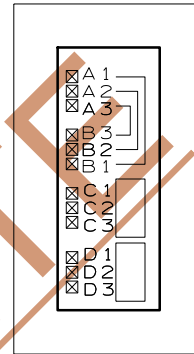

200A DEADFRONT  
SWITCHING CUBICLE STOCK# 66372

SCHEMATIC

**25T421DD\*\*\* ( PMSG-200-12 )**

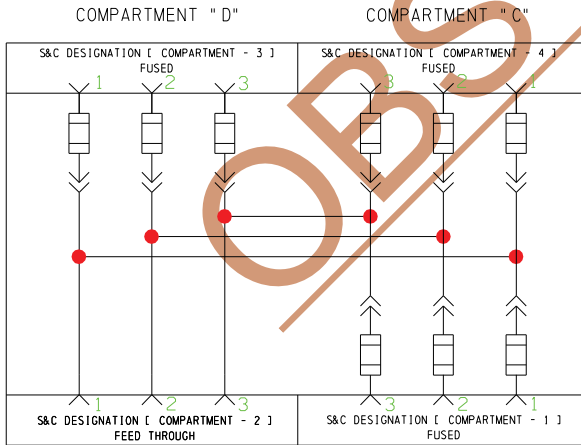

COMPARTMENT "A" COMPARTMENT "B"  
CONNECTION DIAGRAM

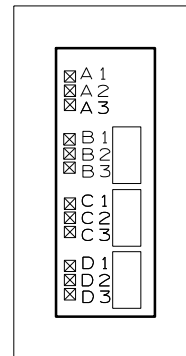

200A DEADFRONT  
SWITCHING CUBICLE STOCK# 06840

SCHEMATIC



APEGGA PERMIT P7061

UNDERGROUND

DISTRIBUTION STANDARDS

REVIEWED BY STANDARDS  
COMMITTEE: 2013-02-12

DRAFTED BY: R. LAWRIE

DESIGNED BY: A. RAHMAN

SCALE: N. T. S.

DATE REVISED: 2018-06-28

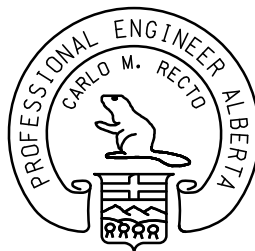

ORIGINAL SIGNED  
DEC. 29, 2016

INSTALLATION OF 25 kV  
4-WAY 3 PHASE 200 AMP  
DEADFRONT SWITCHING CUBICLE

STANDARD NO.

66 00 07 25 23 035

PAGE NO.

2 / 4



**NOTES:**

1. GROUNDING CONNECTION AND DETAILS SHOULD BE AS PER STANDARD 65 00 07 00 60 001.
2. PHYSICAL LOCATION OF SWITCHES & FUSES ARE AS PER SCHEMATICS (SEE PAGE 2).
3. LOAD BREAK ELBOWS ARE TERMINATED AS PER STANDARD 63 00 07 00 48 006.
4. DEAD BREAK ELBOWS ARE TERMINATED AS PER STANDARD 63 00 07 00 48 005.
5. FUSE AS PER STANDARDS 60 00 07 25 50 030 AND 65 00 07 00 23 004.
6. FIBRE OPTICS TO BE INSTALLED AS PER STANDARD 63 00 07 00 23 001.
7. FAULT INDICATORS ARE REQUIRED ON ALL PRIMARY CABLES EXCEPT ON CABLES DIRECTLY FEEDING A 3 PHASE TRANSFORMER.
8. LIFTING EYES MUST BE ROTATED AND FACE DOWN.
9. FOR ANCHORING DETAILS SEE STANDARD 65 00 07 00 23 003.
10. ALL CABLES SHALL HAVE A MINIMUM OF 8 m OF EXTRA CABLE COILED IN THE BASE MEASURED FROM THE TOP OF PIPE OR BASE ENTRY POINT.
11. FOR PRECAST BASE INSTALLATION SEE 65 00 07 25 23 132.

**OBSOLETE**

20180628 11:09 jandrada

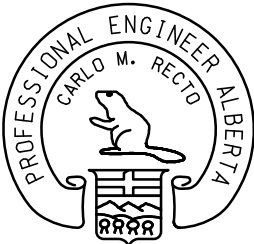
 <p><b>EPCOR</b> APEGGA PERMIT P7061 <b>UNDERGROUND</b> <b>DISTRIBUTION STANDARDS</b></p>	 <p>PROFESSIONAL ENGINEER ALBERTA CARLO M. RECTO</p> <p>ORIGINAL SIGNED DEC. 29, 2016</p>	<p>INSTALLATION OF 25 kV 4-WAY 3 PHASE 200 AMP DEADFRONT SWITCHING CUBICLE</p>	
<p>REVIEWED BY STANDARDS COMMITTEE: 2013-02-12</p> <p>DRAFTED BY: R. LAWRIE</p> <p>DESIGNED BY: A. RAHMAN</p> <p>SCALE: N. T. S.</p> <p>DATE REVISED: 2018-06-28</p>			

ITEM	PART DESCRIPTION	STOCK No.	QTY.
1	CUBICLE SWITCHING DEADFRONT 25 kV 4-WAY 3 PH 200 AMP	AS REQ'D	1
	PMSG-200-9	66372	
	PMSG-200-12	06840	
2	PADLOCK SHORT SHACKLE KEYED ALIKE	N/A	A/R
3	FUSE HOLDER - AS PER NOTE 5	AS REQ'D	A/R
	HOLDER FUSE SME-4Z E-TYPE 25 kV	49725	
	HOLDER FUSE SM-4Z E-TYPE 25 kV	49811	
	HOLDER FUSE COOPER CLIP STYLE 25 kV	49625	
4	FUSE - AS PER NOTE 5	AS REQ'D	A/R
5	KIT CONVERSION FUSE 25 kV TRANSFUSER TO SME-4Z 200A DEADFRONT CUBICLE	22725	A/R
6	SIGN DANGER CUBICLE	65737	2

**OBSOLETE**



APEGGA PERMIT P7061  
**UNDERGROUND DISTRIBUTION STANDARDS**

REVIEWED BY STANDARDS COMMITTEE: 2013-02-12  
 DRAFTED BY: R. LAWRIE  
 DESIGNED BY: A. RAHMAN  
 SCALE: N. T. S.  
 DATE REVISED: 2018-06-28

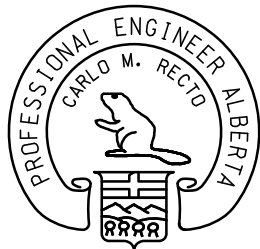

ORIGINAL SIGNED  
 DEC. 29, 2016

INSTALLATION OF 25 kV  
 4-WAY 3 PHASE 200 AMP  
 DEADFRONT SWITCHING CUBICLE

STANDARD NO. **66 00 07 25 23 035** PAGE NO. 4 / 4

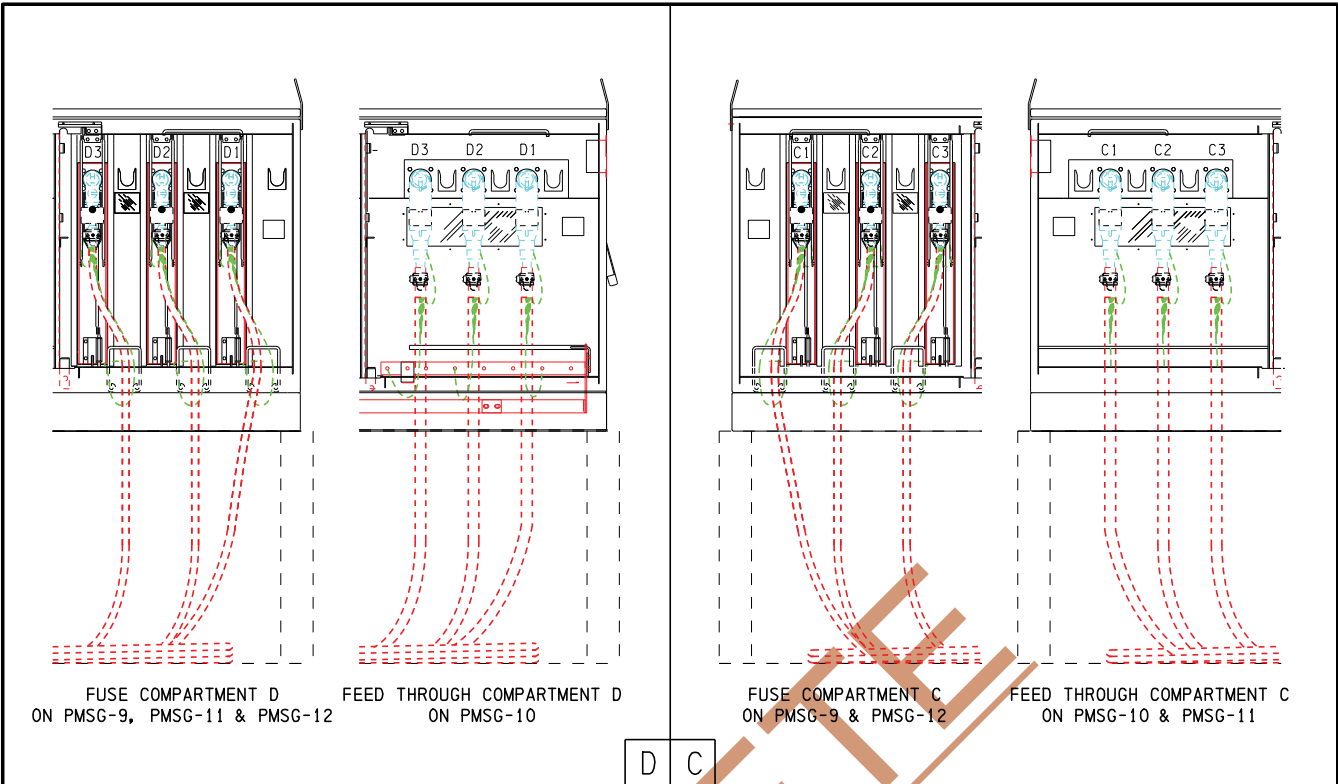

FUSE COMPARTMENT D  
ON PMSG-9, PMSG-11 & PMSG-12

FEED THROUGH COMPARTMENT D  
ON PMSG-10

FUSE COMPARTMENT C  
ON PMSG-9 & PMSG-12

FEED THROUGH COMPARTMENT C  
ON PMSG-10 & PMSG-11

D	C
A	B

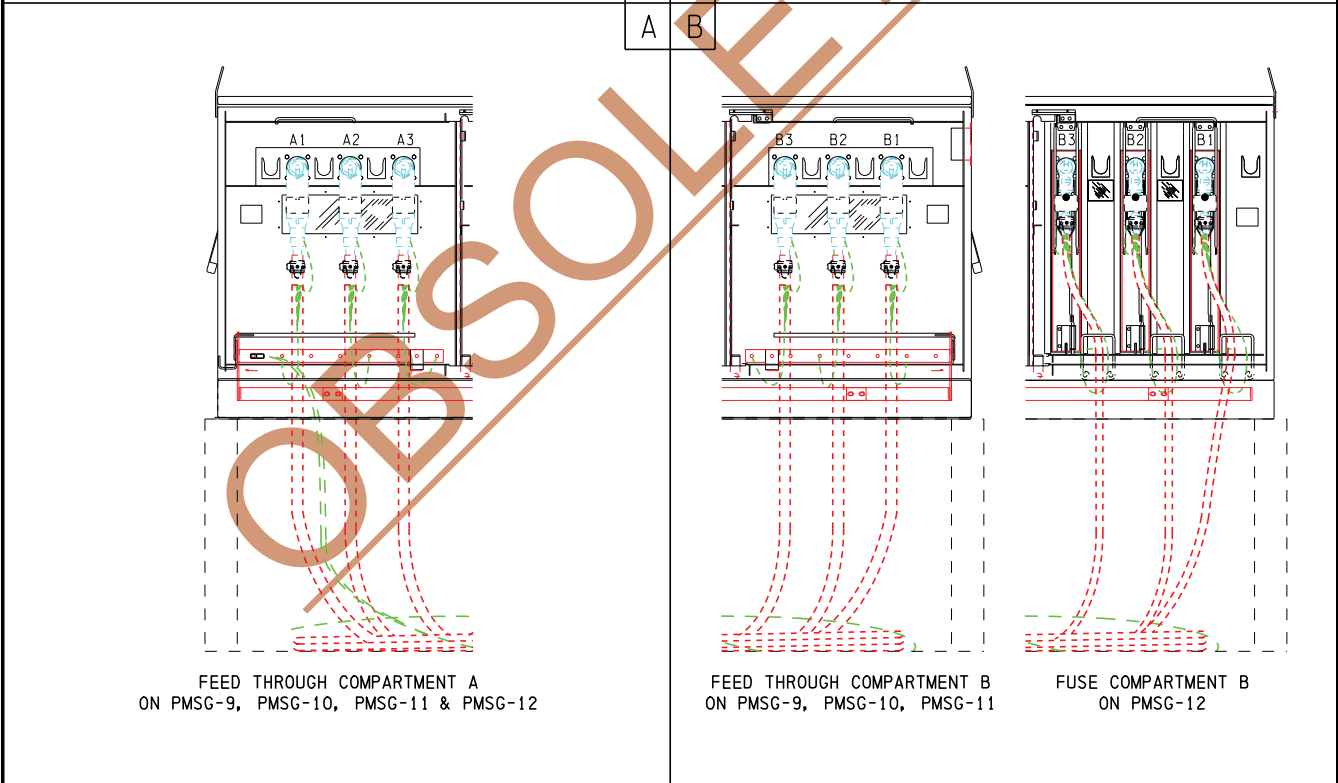

FEED THROUGH COMPARTMENT A  
ON PMSG-9, PMSG-10, PMSG-11 & PMSG-12

FEED THROUGH COMPARTMENT B  
ON PMSG-9, PMSG-10, PMSG-11

FUSE COMPARTMENT B  
ON PMSG-12

20170602 14:03 r lawrie 1:35

**VOLUME 7 - C.O.E.  
DESIGN & CONSTRUCTION  
STANDARDS**

REVIEWED BY STANDARDS  
COMMITTEE: 2013-02-12

DRAFTED BY: R. LAWRIE

DESIGNED BY: A. RAHMAN

SCALE: N. T. S.

DATE REVISED: 2017-01-04



**INSTALLATION OF 25 kV  
4-WAY 3 PHASE 600 AMP  
DEADFRONT SWITCHING CUBICLES  
[ALL VARIANTS]**

STANDARD NO.  
**65 00 07 25 23 032**

PAGE NO.  
1 / 5

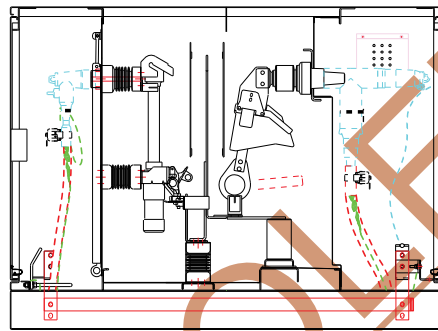
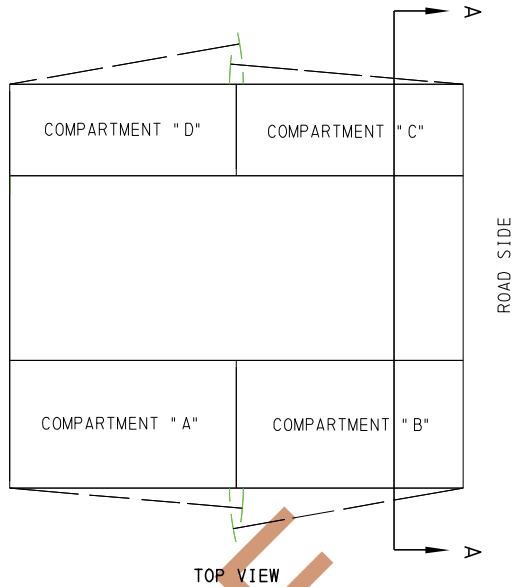
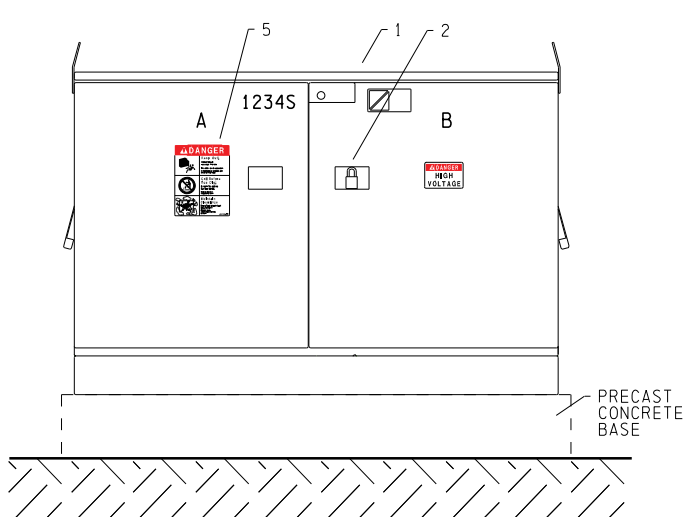

SME-4Z FUSE FITTED  
SECTION THROUGH DETAIL A-A  
(MSG-9)

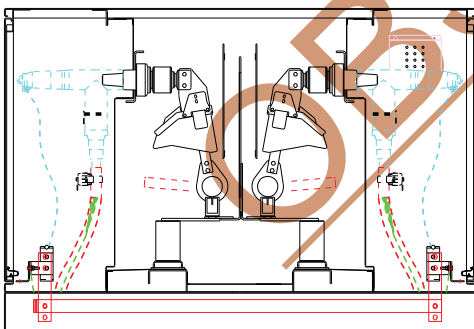

SECTION THROUGH DETAIL A-A  
(MSG-10, MSG-11)

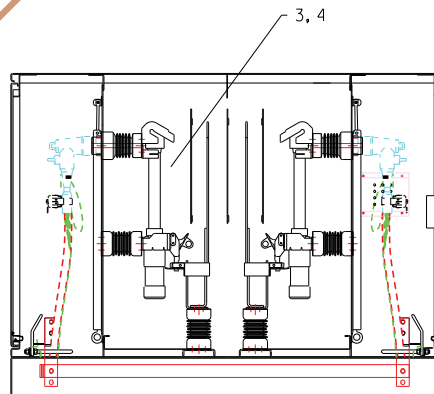

SME-4Z FUSE FITTED  
SECTION THROUGH DETAIL A-A  
(MSG-12)

VOLUME 7 - C.O.E.  
DESIGN & CONSTRUCTION  
STANDARDS

REVIEWED BY STANDARDS  
COMMITTEE: 2013-02-12  
DRAFTED BY: R. LAWRIE  
DESIGNED BY: A. RAHMAN  
SCALE: N. T. S.  
DATE REVISED: 2017-01-04



INSTALLATION OF 25 kV  
4-WAY 3 PHASE 600 AMP  
DEADFRONT SWITCHING CUBICLES  
[ALL VARIANTS]

STANDARD NO.  
65 00 07 25 23 032

PAGE NO.  
2 / 5

25T462DD\*\*\*

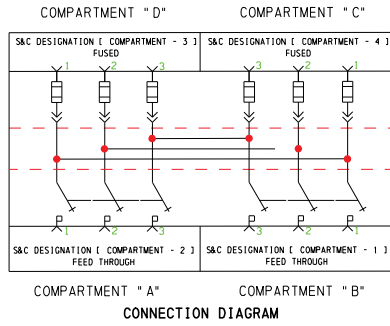

PMSG-9

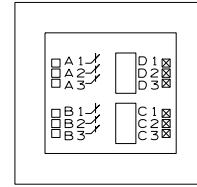

25T464DD\*\*\*

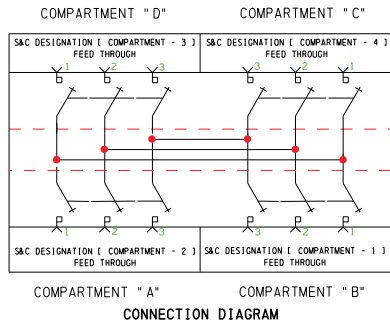

PMSG-10

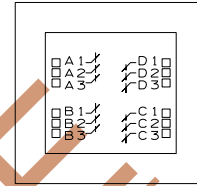

25T463DD\*\*\*

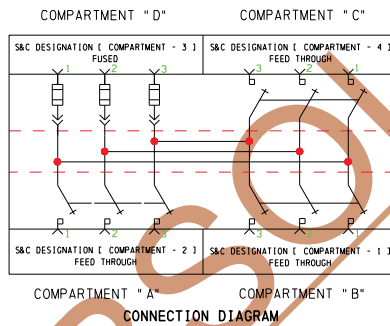

PMSG-11

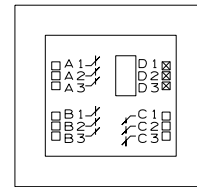

25T461DD\*\*\*

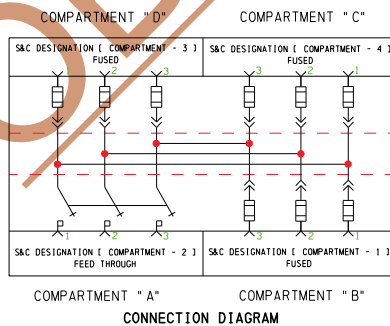

PMSG-12

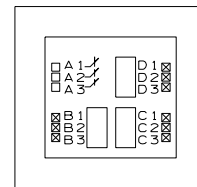

VOLUME 7 - C.O.E.  
DESIGN & CONSTRUCTION  
STANDARDS

REVIEWED BY STANDARDS  
COMMITTEE: 2013-02-12

DRAFTED BY: R. LAWRIE

DESIGNED BY: A. RAHMAN

SCALE: N. T. S.

DATE REVISED: 2017-01-04



INSTALLATION OF 25 kV  
4-WAY 3 PHASE 600 AMP  
DEADFRONT SWITCHING CUBICLES  
[ ALL VARIANTS ]

STANDARD NO.

65 00 07 25 23 032

PAGE NO.

3 / 5

20170602 14:04 r lawrie

**NOTES:**

1. GROUNDING CONNECTION AND DETAILS SHOULD BE AS PER STANDARD 65 00 07 00 60 001.
2. PHYSICAL LOCATION OF SWITCHES & FUSES ARE AS PER SCHEMATICS (SEE PAGE 2).
3. LOAD BREAK ELBOWS ARE TERMINATED AS PER STANDARD 63 00 07 00 48 006.
4. DEAD BREAK ELBOWS ARE TERMINATED AS PER STANDARD 63 00 07 00 48 005.
5. FUSE AS PER STANDARDS 60 00 07 25 50 030 AND 65 00 07 00 23 004.
6. FIBRE OPTICS TO BE INSTALLED AS PER STANDARD 63 00 07 00 23 001.
7. FAULT INDICATORS ARE REQUIRED ON ALL PRIMARY CABLES EXCEPT ON CABLES DIRECTLY FEEDING A 3 PHASE TRANSFORMER.
8. LIFTING EYES MUST BE ROTATED AND FACE DOWN.
9. FOR ANCHORING DETAILS SEE STANDARD 65 00 07 00 23 003.
10. ALL CABLES SHALL HAVE A MINIMUM OF 8 m OF EXTRA CABLE COILED IN THE BASE MEASURED FROM THE TOP OF PIPE OR BASE ENTRY POINT.
11. FOR PRECAST BASE INSTALLATION SEE 65 00 07 25 23 132.

**OBSOLETE**

**VOLUME 7 - C.O.E.  
DESIGN & CONSTRUCTION  
STANDARDS**

REVIEWED BY STANDARDS  
COMMITTEE: 2013-02-12

DRAFTED BY: R. LAWRIE

DESIGNED BY: A. RAHMAN

SCALE: N. T. S.

DATE REVISED: 2017-01-04



**INSTALLATION OF 25 kV  
4-WAY 3 PHASE 600 AMP  
DEADFRONT SWITCHING CUBICLES  
[ALL VARIANTS]**

STANDARD NO.

**65 00 07 25 23 032**

PAGE NO.

4 / 5



20170629 14:22 r lowrie 1:35

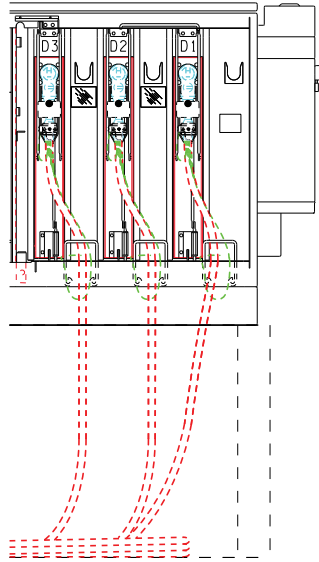

FUSE COMPARTMENT D  
ON PMSG-9 & PMSG-11

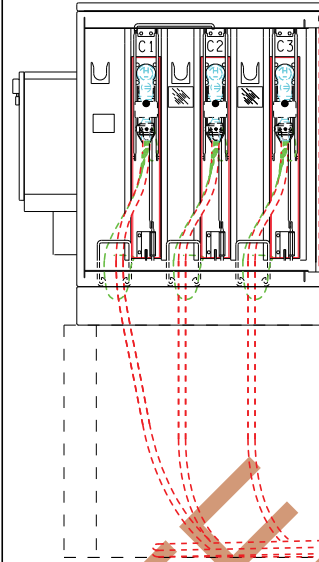

FUSE COMPARTMENT C  
ON PMSG-9

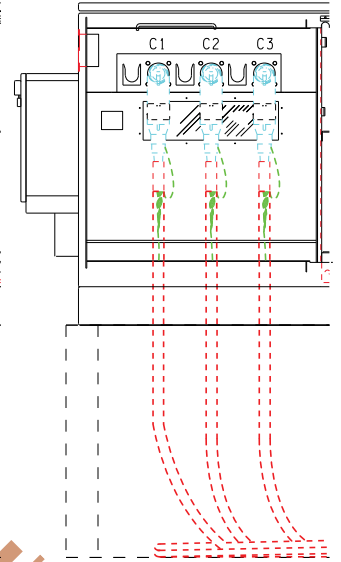

FEED THROUGH  
COMPARTMENT C  
ON PMSG-11

D	C
A	B

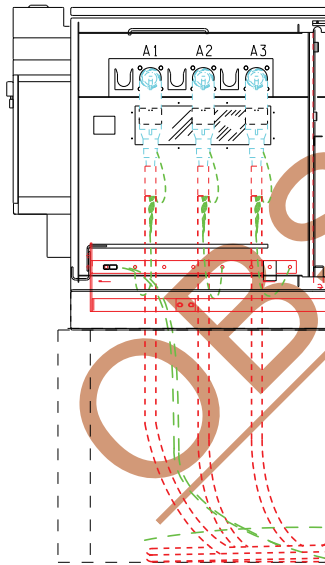

FEED THROUGH COMPARTMENT A  
ON PMSG-9 & PMSG-11

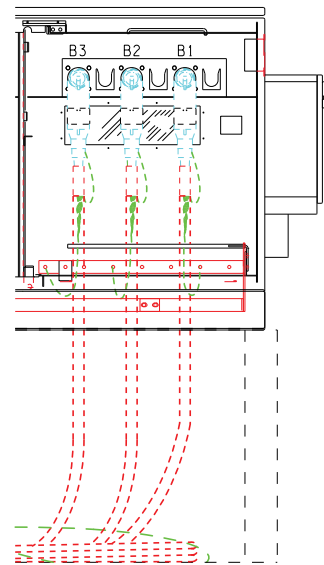

FEED THROUGH COMPARTMENT B  
ON PMSG-9 & PMSG-11

**VOLUME 7 - C.O.E.  
DESIGN & CONSTRUCTION  
STANDARDS**

REVIEWED BY STANDARDS  
COMMITTEE: 2013-08-27

DRAFTED BY: R. SARNECKI

DESIGNED BY: A. RAHMAN

SCALE: N. T. S.

DATE REVISED: 2017-01-03



**INSTALLATION OF 25 kV  
4-WAY 3 PHASE 600 AMP  
DEADFRONT SWITCHING CUBICLES  
FOR DISTRIBUTION  
AUTOMATION**

STANDARD NO.  
**65 00 07 25 23 030**

PAGE NO.  
1 / 4



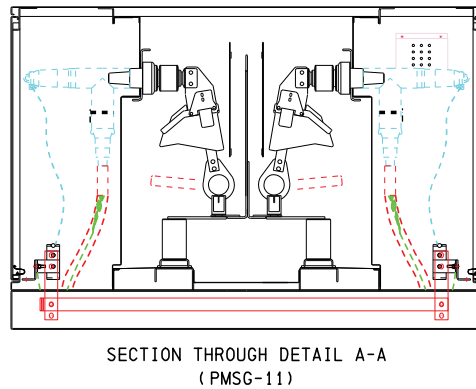
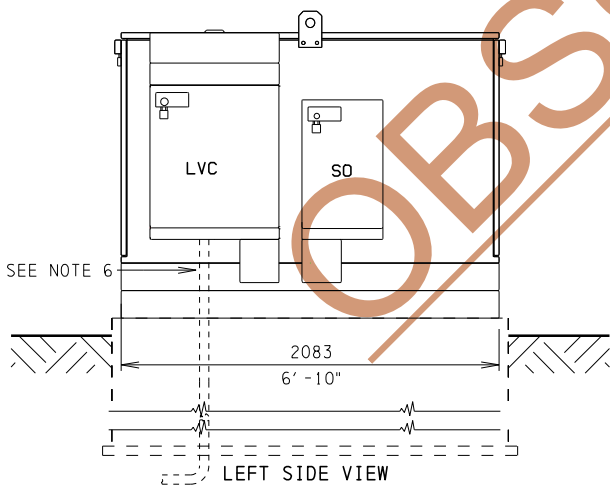
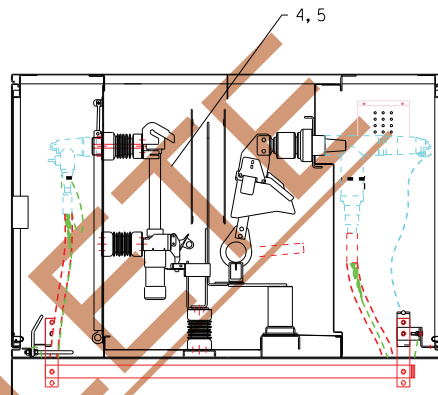
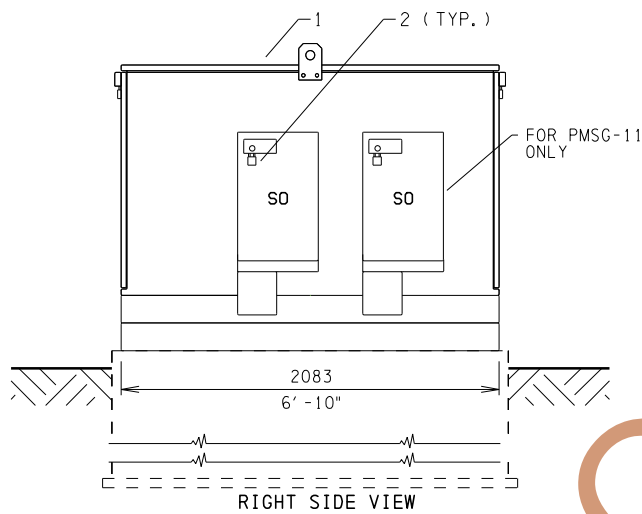
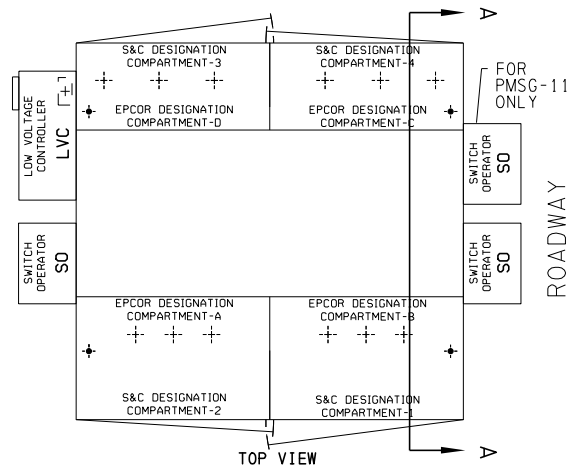
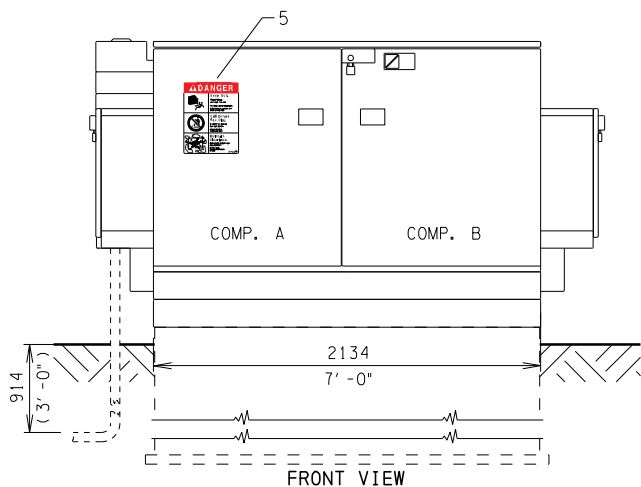

ALL DIMENSIONS ARE IN MILLIMETERS (INCHES) UNLESS OTHERWISE INDICATED

**VOLUME 7 - C.O.E.  
DESIGN & CONSTRUCTION  
STANDARDS**

REVIEWED BY STANDARDS COMMITTEE: 2013-08-27  
 DRAFTED BY: R. SARNECKI  
 DESIGNED BY: A. RAHMAN  
 SCALE: N. T. S.  
 DATE REVISED: 2017-01-03



**INSTALLATION OF 25 kV  
4-WAY 3 PHASE 600 AMP  
DEADFRONT SWITCHING CUBICLES  
FOR DISTRIBUTION  
AUTOMATION**

STANDARD NO.  
**65 00 07 25 23 030**

PAGE NO.  
2 / 4

25T462DDA\*\*\*

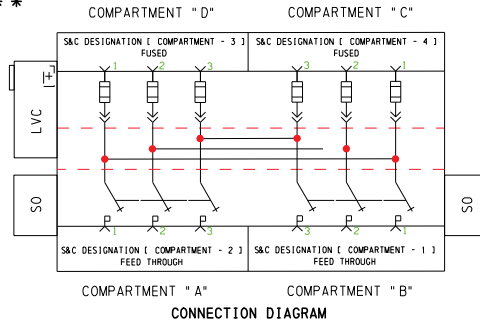

PMSG-9

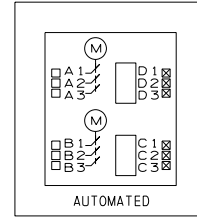

SWITCHING CUBICLE STOCK# 69222  
SCHEMATIC

25T463DDA\*\*\*

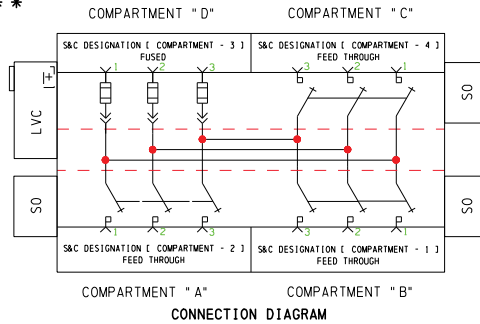

PMSG-11

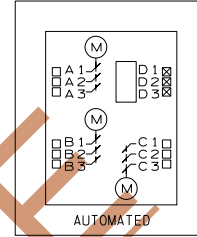

SWITCHING CUBICLE STOCK# 55808  
SCHEMATIC

NOTE: PMSG-10 & PMSG-12 ARE NOT AVAILABLE.

**NOTES:**

1. GROUNDING CONNECTION AND DETAILS SHOULD BE AS PER STANDARD 65 00 07 00 60 001.
2. PHYSICAL LOCATION OF SWITCHES AS PER PAGE 2 & FUSES ARE AS PER SCHEMATICS ON THIS PAGE.
3. LOAD BREAK ELBOWS ARE TERMINATED AS PER STANDARD 63 00 07 00 48 006.
4. DEAD BREAK ELBOWS ARE TERMINATED AS PER STANDARD 63 00 07 00 48 007.
5. FUSE AS PER STANDARD 60 00 07 25 50 030.
6. IF AN EXTERNAL ANTENNA IS REQUIRED, A 51 mm (2") FLEXIBLE CONDUIT MUST BE INSTALLED INTO THE LOW VOLTAGE CONTOLLER COMPARTMENT. FIELD DRILL INTO THE LVC IS NECESSARY TO ACCOMODATE THE 2" FLEXIBLE CONDUIT.
7. LIFTING EYES MUST BE ROTATED AND FACE DOWN.
8. FOR ANCHORING DETAILS SEE STANDARD 65 00 07 00 23 003.
9. ALL CABLES SHALL HAVE A MINIMUM OF 8 m OF CABLE COILED IN BASE MEASURED FROM THE TOP OF PIPE OR THE BASE ENTRY POINT.
10. FOR PRECAST BASE INSTALLATION SEE 65 00 07 25 23 132.

20170629 14:23 rlowrie

**VOLUME 7 - C.O.E.  
DESIGN & CONSTRUCTION  
STANDARDS**

REVIEWED BY STANDARDS  
COMMITTEE: 2013-08-27

DRAFTED BY: R. SARNECKI

DESIGNED BY: A. RAHMAN

SCALE: N. T. S.

DATE REVISED: 2017-01-03



**INSTALLATION OF 25 kV  
4-WAY 3 PHASE 600 AMP  
DEADFRONT SWITCHING CUBICLES  
FOR DISTRIBUTION  
AUTOMATION**

STANDARD NO.  
**65 00 07 25 23 030**

PAGE NO.  
3 / 4



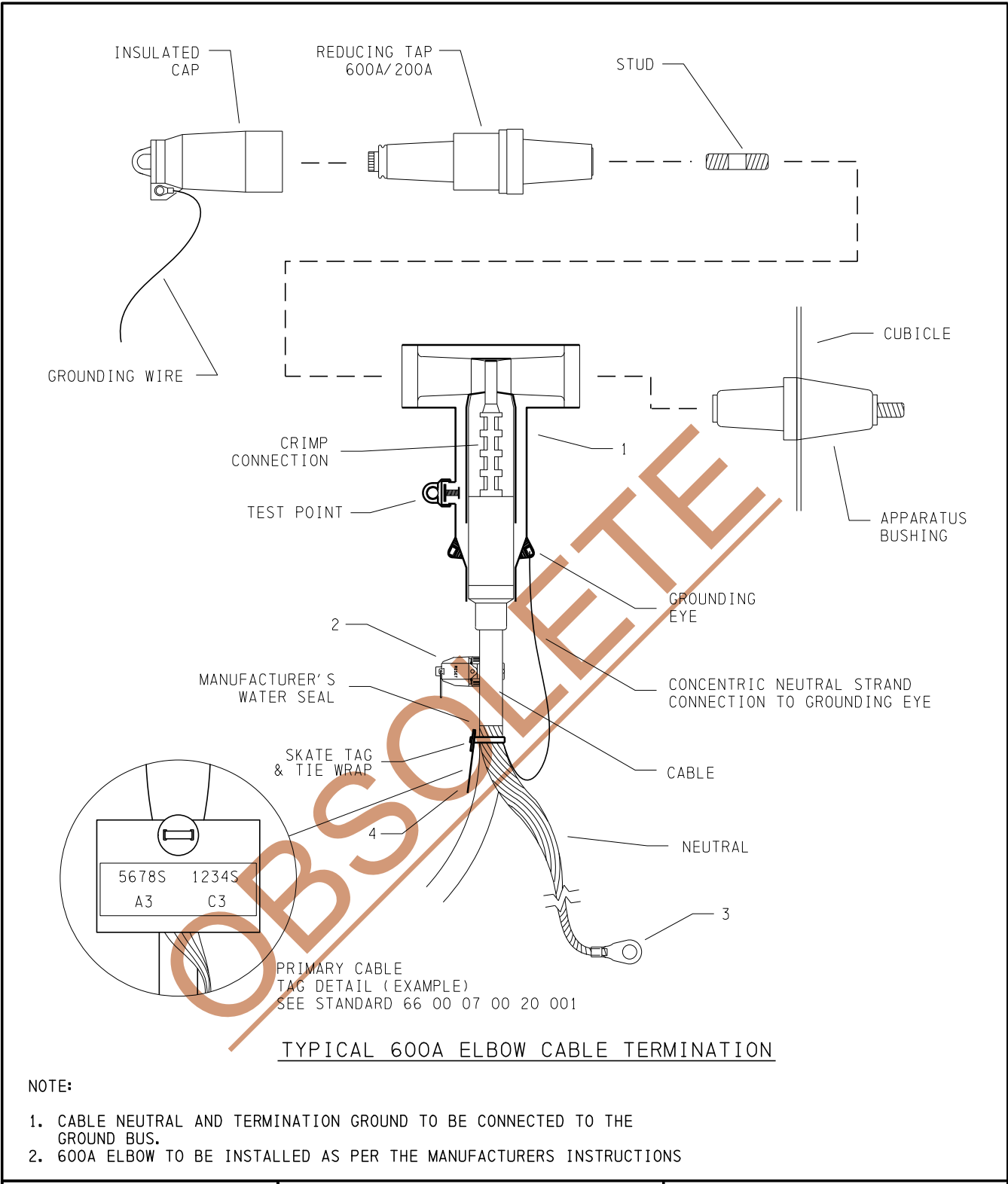

TYPICAL 600A ELBOW CABLE TERMINATION

NOTE:

1. CABLE NEUTRAL AND TERMINATION GROUND TO BE CONNECTED TO THE GROUND BUS.
2. 600A ELBOW TO BE INSTALLED AS PER THE MANUFACTURERS INSTRUCTIONS

20170602 08:26 r lawrie

<b>VOLUME 7 - C.O.E. DESIGN &amp; CONSTRUCTION STANDARDS</b>	
REVIEWED BY STANDARDS COMMITTEE:	2013-01-08
DRAFTED BY:	R. LAWRIE
DESIGNED BY:	A. RAHMAN
SCALE:	N. T. S.
DATE REVISED:	2016-12-30



**TERMINATION OF XLPE/EPR  
CABLES USING 600 A ELBOWS**

STANDARD NO. <b>63 00 07 00 48 005</b>	PAGE NO. 1 / 2
-------------------------------------------	-------------------



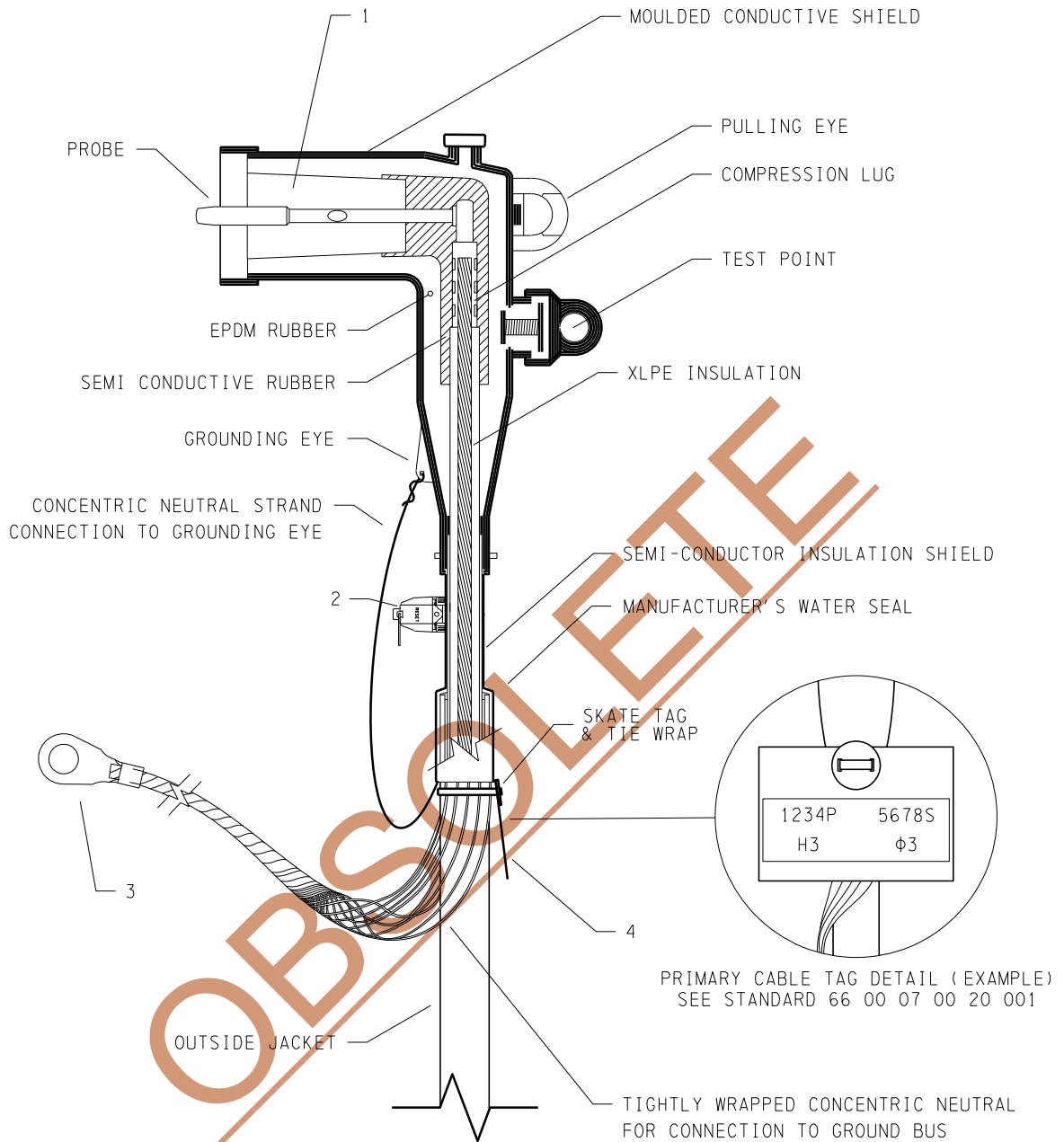

20170602 09:53 r lawrie

**VOLUME 7 - C.O.E.  
DESIGN & CONSTRUCTION  
STANDARDS**

REVIEWED BY STANDARDS  
COMMITTEE: 2013-01-08

DRAFTED BY: R. LAWRIE

DESIGNED BY: A. RAHMAN

SCALE: N. T. S.

DATE REVISED: 2016-12-27



**TERMINATION OF XLPE/EPR CABLE  
USING 200 AMP ELBOWS**

STANDARD NO.  
**63 00 07 00 48 006**

PAGE NO.  
1 / 3

## IMPORTANT NOTES

1. CHECK CONTENTS OF PACKAGE TO ENSURE THEY ARE COMPLETE AND UNDAMAGED.
2. CHECK ALL COMPONENTS TO ENSURE PROPER VOLTAGE CLASS AND PROPER FIT WITH CABLE AND/OR MATING PRODUCTS.
3. READ ENTIRE INSTALLATION INSTRUCTIONS BEFORE STARTING.
4. HAVE ALL REQUIRED TOOLS AT HAND AND MAINTAIN CLEANLINESS THROUGHOUT THE PROCEDURE.
5. THE INSTALLATION INSTRUCTIONS FOR THE ELBOW AND RELATED PARTS THAT ARE PROVIDED BY THE MANUFACTURER ARE TO BE FOLLOWED IN THE SEQUENCE AS OUTLINED.
6. DURING INSTALLATION, THE MALE CONTACT PIN IS TO BE ABSOLUTELY FREE OF ANY LUBRICANT AND IS TO BE INSTALLED BY USING THE PROBE TORQUE WRENCH.
7. SILICON GREASE SHALL BE APPLIED AND THE ELBOW CONNECTOR PLACED ON THE BUSHING BY PRESSING THE ELBOW STRAIGHT ONTO THE BUSHING WITH SUFFICIENT FORCE TO ENSURE THAT THE TOP OF THE BUSHING IS FIRMLY LOCKED INTO PLACE (DO NOT OPERATE BY HAND). A VISUAL CHECK SHOULD BE CARRIED OUT TO ENSURE THAT THE SKIRT OF THE ELBOW IS COMPLETELY OVER THE SEMI-CONDUCTING PORTION OF THE BUSHING.

OBSOLETE

**VOLUME 7 - C.O.E.  
DESIGN & CONSTRUCTION  
STANDARDS**

REVIEWED BY STANDARDS  
COMMITTEE: 2013-01-08

DRAFTED BY: R. LAWRIE

DESIGNED BY: A. RAHMAN

SCALE: N. T. S.

DATE REVISED: 2016-12-27



**TERMINATION OF XLPE/EPR CABLE  
USING 200 AMP ELBOWS**

STANDARD NO.

**63 00 07 00 48 006**

PAGE NO.

2 / 3





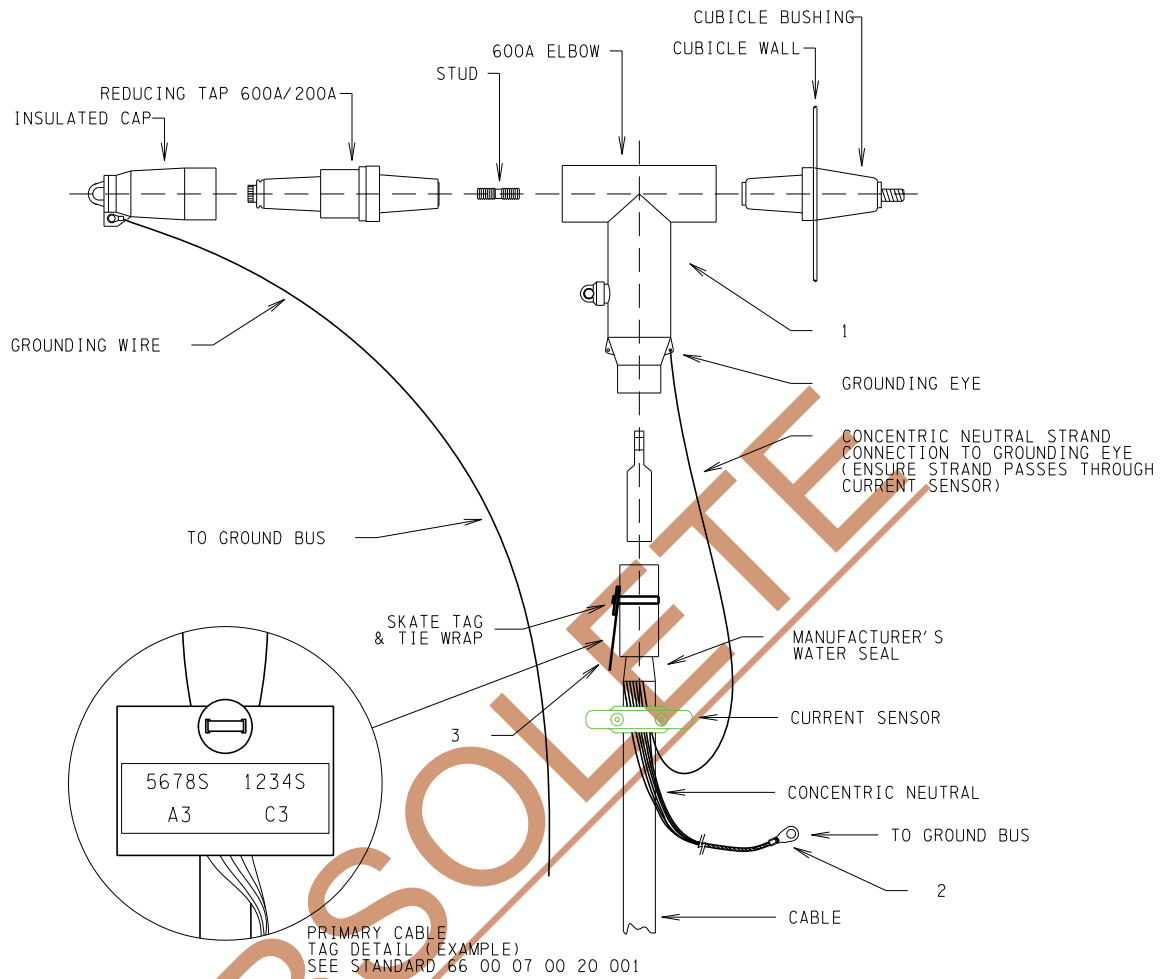

**TYPICAL 600A ELBOW CABLE TERMINATION  
WITH CURRENT SENSOR**

**NOTES:**

1. THE CURRENT SENSOR IS PLACED BELOW THE CABLE TERMINATOR, AROUND THE CONDUCTOR'S CONCENTRIC NEUTRAL. THE CONDUCTOR'S EXPOSED CONCENTRIC NEUTRAL MUST BE BROUGHT BACK THROUGH THE SENSOR.
2. CABLE PREPARATION AND ELBOW CONNECTION SHOULD BE AS PER MANUFACTURER'S INSTRUCTIONS.
3. FAULT INDICATORS ARE NOT REQUIRED.

ALL DIMENSIONS ARE IN MILLIMETERS (INCHES) UNLESS OTHERWISE SPECIFIED.

**VOLUME 7 - C.O.E.  
DESIGN & CONSTRUCTION  
STANDARDS**

REVIEWED BY STANDARDS  
COMMITTEE: 2013-01-08  
DRAFTED BY: R. LAWRIE  
DESIGNED BY: T. SHMYR  
SCALE: N. T. S.  
DATE REVISED: 2017-01-06



**TERMINATION OF  
XLPE/EPR CABLES USING  
600 A ELBOWS FOR  
DISTRIBUTION AUTOMATION**

STANDARD NO.  
**63 00 07 00 48 007**

PAGE NO.  
1 / 4

1:100

20170602 10:14 r lawrie

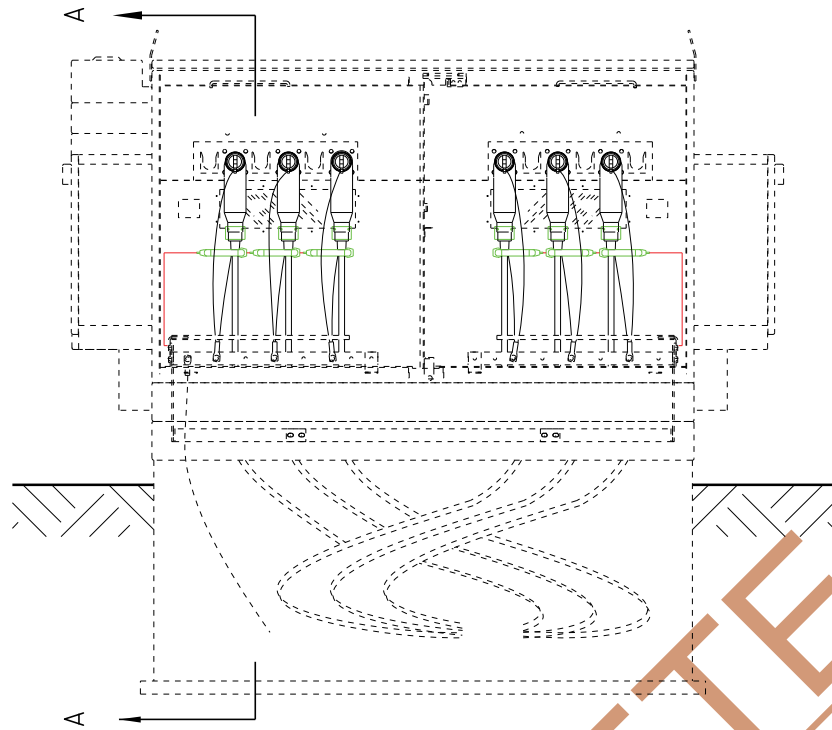

FRONT VIEW ( 600A )

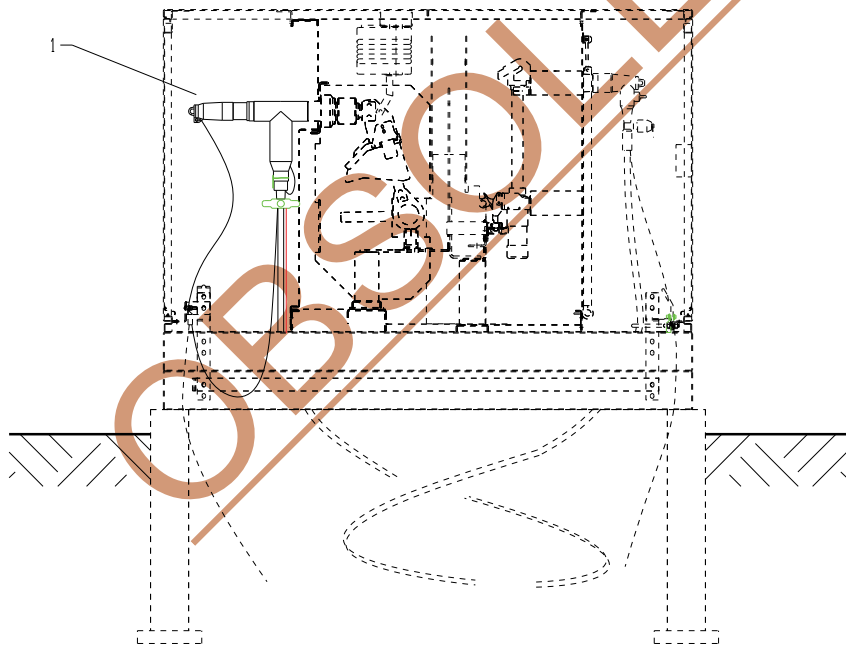

SECTION A - A

VOLUME 7 - C.O.E.  
DESIGN & CONSTRUCTION  
STANDARDS

REVIEWED BY STANDARDS  
COMMITTEE: 2013-01-08

DRAFTED BY: R. LAWRIE

DESIGNED BY: T. SHMYR

SCALE: N. T. S.

DATE REVISED: 2017-01-06



TERMINATION OF  
XLPE/EPR CABLES USING  
600 A ELBOWS FOR  
DISTRIBUTION AUTOMATION

STANDARD NO.

63 00 07 00 48 007

PAGE NO.

2 / 4

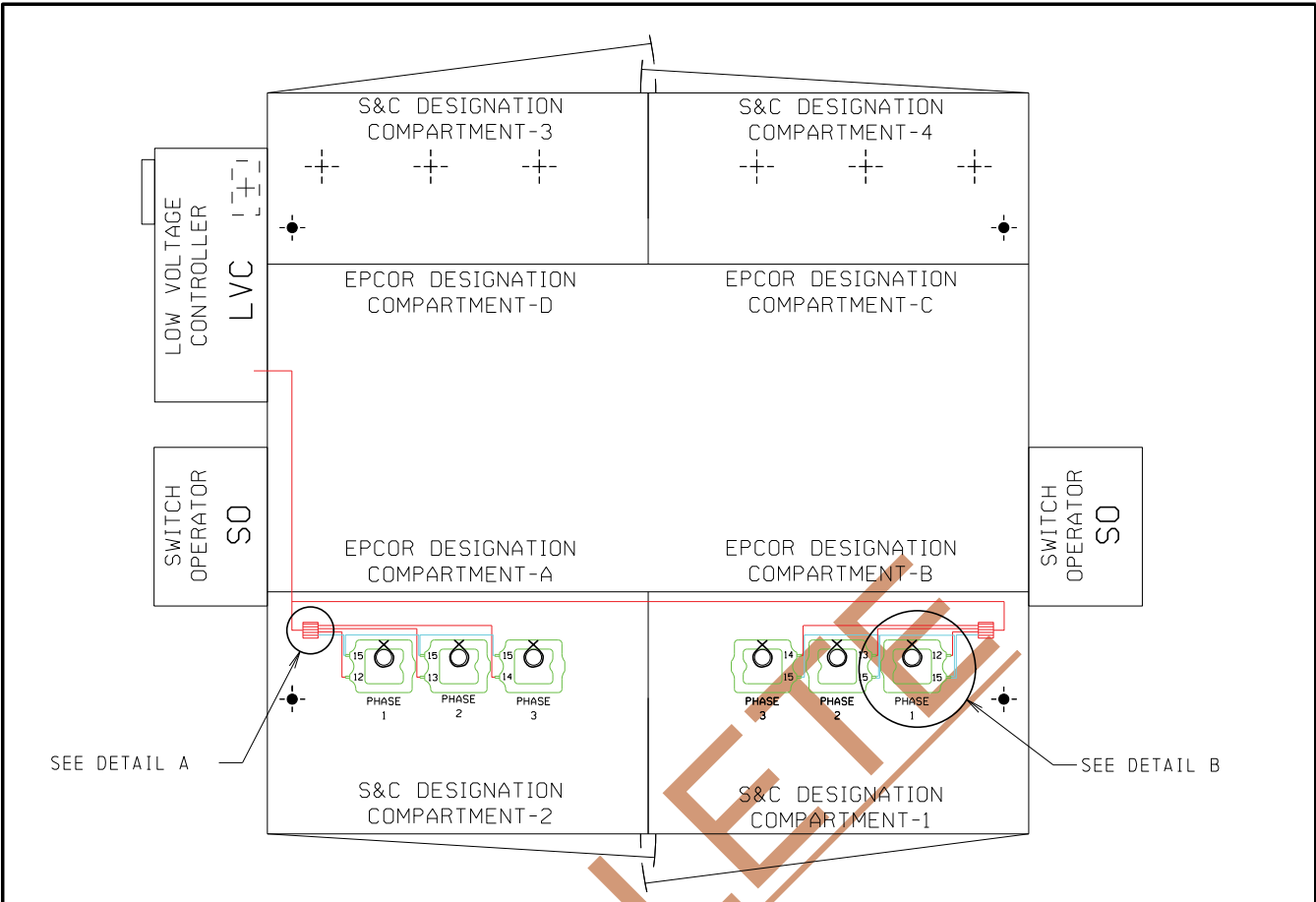

TOP VIEW  
CURRENT SENSOR & WIRE HARNESS DIAGRAM

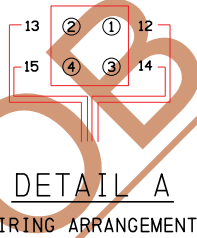

DETAIL A  
WIRING ARRANGEMENT

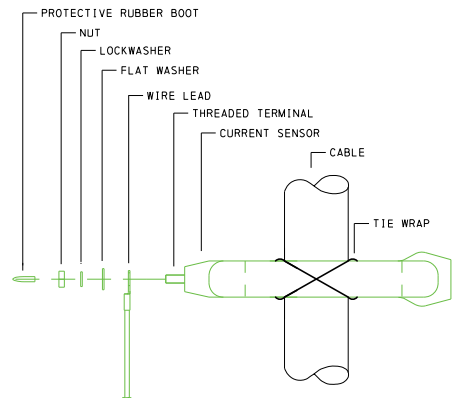

DETAIL B REAR VIEW  
CURRENT SENSOR MOUNTING

NOTES ON CURRENT SENSORS:

1. CURRENT SENSORS WILL BE SUSCEPTIBLE TO SHORT CIRCUITING IF THREADED TERMINALS ARE EXPOSED. DO NOT USE CURRENT SENSORS WITHOUT PROTECTIVE RUBBER BOOTS FIRMLY IN PLACE ON TERMINALS.
2. REMOVE THE SHORTING RECEPTACLE PRIOR TO CONNECTING THE WIRING HARNESS TO THE SWITCH AND STORE THEM IN THE LVC BOX. RECONNECT THE SHORTING RECEPTACLE WHENEVER IT IS DISCONNECTED FROM THE SWITCH.

20170602 10:15 r lawrie 1:50

VOLUME 7 - C.O.E.  
DESIGN & CONSTRUCTION  
STANDARDS

REVIEWED BY STANDARDS  
COMMITTEE: 2013-01-08  
DRAFTED BY: R. LAWRIE  
DESIGNED BY: T. SHMYR  
SCALE: N. T. S.  
DATE REVISED: 2017-01-06



TERMINATION OF  
XLPE/EPR CABLES USING  
600 A ELBOWS FOR  
DISTRIBUTION AUTOMATION

STANDARD NO.  
63 00 07 00 48 007

PAGE NO.  
3 / 4



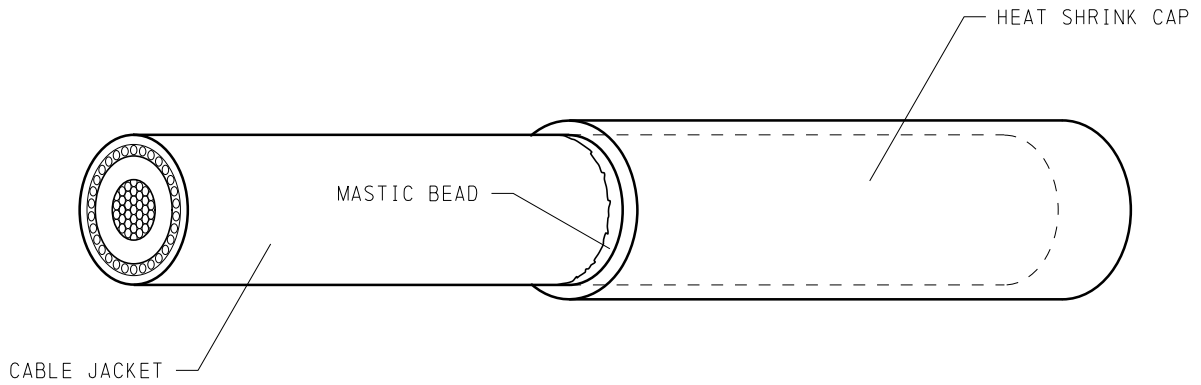

SINGLE CONDUCTOR CABLE  
 NOTE: MASTIC BEAD IS AN INTERNAL PART OF THE CAP

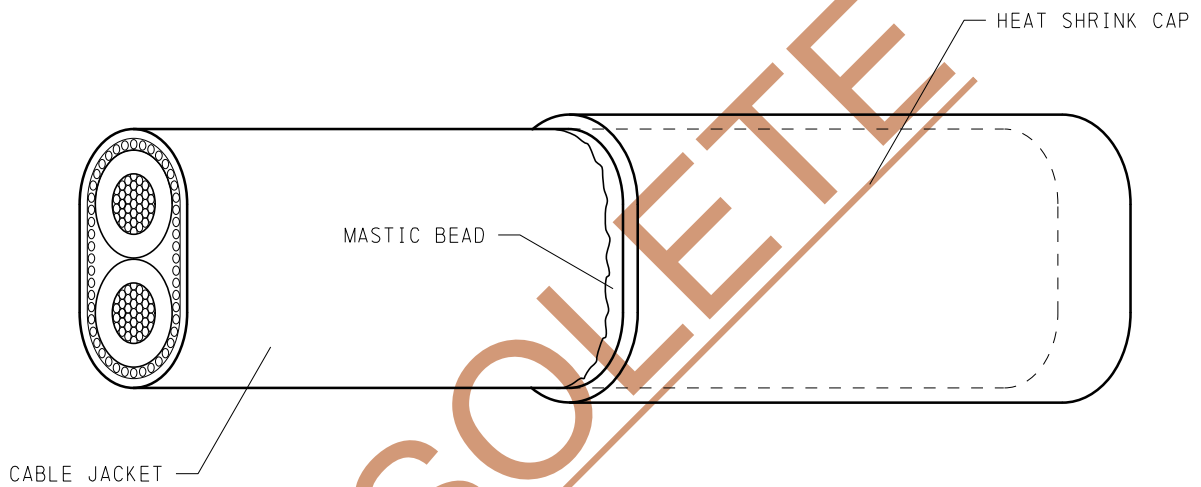

USEB90 SECONDARY CABLE

**INSTALLATION PROCEDURE:**

1. ABRABE CABLE JACKET WHERE END-CAP WILL BE LOCATED.
2. CLEAN END OF CABLE AND SLIDE END-CAP INTO PLACE.
3. HEAT END-CAP BEGINNING FROM THE CLOSED END TO ENSURE UNIFORM SHRINKAGE.
4. REMOVE HEAT SOURCE WHEN END-CAP HAS SHRUNK ENOUGH THAT IT ASSUMES CABLE SHAPE AND SEALANT FLOWS OUT.

REFER TO NOTES AND CHARTS  
 PAGE 2 FOR REQUIRED SIZES.

20170602 16:10 r lawrie

<b>VOLUME 7 - C.O.E. DESIGN &amp; CONSTRUCTION STANDARDS</b>	
REVIEWED BY STANDARDS COMMITTEE:	2014-07-08
DRAFTED BY:	R. LAWRIE
DESIGNED BY:	A. RAHMAN
SCALE:	N. T. S.
DATE REVISED:	2014-08-26



SEALING OF  
 XLPE/EPR CONCENTRIC NEUTRAL  
 AND USEB90 ( SECONDARY )  
 CABLE ENDS

STANDARD NO. <b>66 00 07 00 48 175</b>	PAGE NO. 1 / 2
-------------------------------------------	-------------------

3M HEAT SHRINK CABLE END CAPS CATALOGUE NUMBERS

CONCENTRIC NEUTRAL PRIMARY CABLE

CABLE SIZE	600V	STOCK #	15kV	STOCK #	25kV	STOCK #
1/0	-	-	SKE-15/40	8929	SKE-25/63	8929
500MCM	-	-	SKE-25/63	9135	SKE-25/63	9135
750MCM	-	-	SKE-30/76	85926	SKE-30/76	85926

USEB 90 SECONDARY CABLE

CABLE SIZE	600V	STOCK #	15kV	STOCK #	25kV	STOCK #
#4	SKE-15/40	8929	-	-	-	-
#2	SKE-15/40	8929	-	-	-	-
1/0	SKE-25/63	9135	-	-	-	-
2/0	SKE-25/63	9135	-	-	-	-
4/0	SKE-25/63	9135	-	-	-	-

**NOTE:**

THE USE OF ELECTRICAL TAPE IS NOT ACCEPTABLE FOR SEALING CABLES

OBSOLETE

**VOLUME 7 - C.O.E.  
DESIGN & CONSTRUCTION  
STANDARDS**

REVIEWED BY STANDARDS  
COMMITTEE: 2014-07-08

DRAFTED BY: R. LAWRIE

DESIGNED BY: A. RAHMAN

SCALE: N. T. S.

DATE REVISED: 2014-08-26



**SEALING OF  
XLPE/EPR CONCENTRIC NEUTRAL  
AND USEB90 (SECONDARY)  
CABLE ENDS**

STANDARD NO.

**66 00 07 00 48 175**

PAGE NO.

2 / 2

TYPICAL INSTALLATION

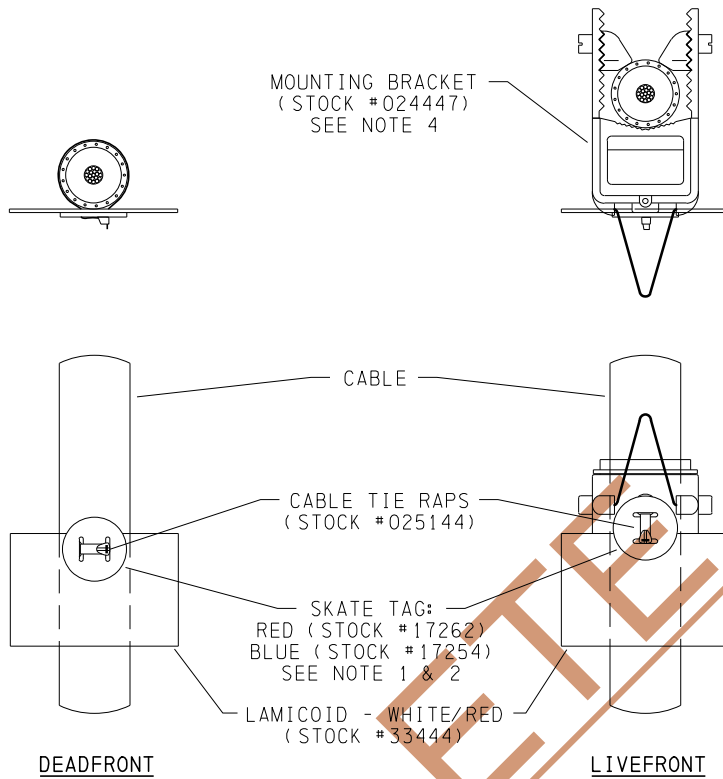

TYPICAL LABELLING INFORMATION

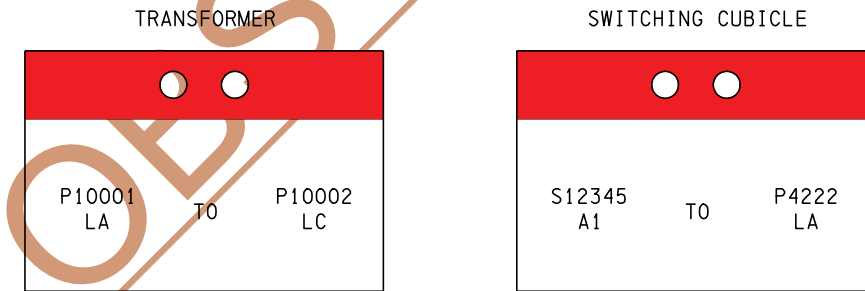

NOTES:

1. SKATE TAG COLOUR APPLICATION IS AS FOLLOWS: RED SKATE TAGS FOR 15 KV. BLUE SKATE TAGS FOR 25 KV.
2. IN THE CASE OF OLD 25 KV NON-COLD-WEATHER-OPERABLE ELBOWS, RED SKATE TAGS SHOULD BE USED.
3. LABEL INFORMATION SHOULD BE TYPE-WRITTEN WHENEVER POSSIBLE; AVOID HAND-WRITTEN LABELS.
4. MOUNTING BRACKET IS REQUIRED ON LIVEFRONT SYSTEMS ONLY.

20170602 15:24 r lawrie

**VOLUME 7 - C.O.E.  
DESIGN & CONSTRUCTION  
STANDARDS**

REVIEWED BY STANDARDS  
COMMITTEE: 2014-05-20

DRAFTED BY: R. LAWRIE

DESIGNED BY: A. RAHMAN

SCALE: N. T. S.

DATE REVISED: 2016-03-15



**CUBICLE AND TRANSFORMER  
CABLE IDENTIFICATION TAG**

STANDARD NO.  
**66 00 07 00 20 001**

PAGE NO.  
1 / 1

**TABLES FOR STRAIGHT SPLICES**

COLD SHRINK, MECHANICAL CONNECTOR, COPPER SLEEVE & HEAT SHRINK JACKET SPLICE KIT					
CABLE TYPE	COLD SHRINK STOCK NO.	MECHANICAL CONNECTOR STOCK NO.	NEUTRAL SLEEVE STOCK NO.	HEAT SHRINK WRAP AROUND (ZIPPER TYPE) STOCK NO. (NOTE 2)	REMARKS
ITEM NUMBER	1	2	3	4	
1/0 AL 15 kV	28422	32344	25054	58932	-
2/0 CU 15 kV	28422	32344	25054	58932	-
500 MCM CU 15 kV	28465	32345	25057	67824	-
750 MCM CU 15 kV FN	54580	32346	SEE REMARK	67824	REQUIRES LC ADAPTER KIT STOCK ITEM 5
750 MCM CU 15 kV CN	54580	32346	25060	67824	-
750 MCM CU 15 kV LC	54580	32346	SEE REMARK	67824	REQUIRES LC ADAPTER KIT STOCK ITEM 5
1/0 AL 25 kV	28463	32344	25054	67824	-
500 MCM AL 25 kV	28465	32345	25057	67824	-
750 MCM CU 28 kV	54580	32346	25060	67824	-

PREMOULDED SPLICE KITS, COPPER SLEEVE & HEAT SHRINK JACKET SPLICE KIT					
CABLE TYPE	PREMOULDED SPLICE KIT STOCK NO.	NEUTRAL SLEEVE STOCK NO.	HEAT SHRINK WRAP AROUND (ZIPPER TUBE) STOCK NO. (NOTE 2)	REMARKS	
ITEM NUMBER	1	2	3	4	
1/0 AL 15 kV	32925	-	25054	58932	SEE NOTE 1
500 MCM CU 15 kV	15233	-	25057	67824	SEE NOTE 1
1/0 AL 25 kV	07285	-	25054	67824	SEE NOTE 1
500 MCM AL 25 kV	15133	-	25057	67824	SEE NOTE 1

**NOTES:**

1. PREMOULDED KITS ARE PREFERRED FOR DIRECT BURIED SPLICES.
2. THE MANUFACTURER'S INSTRUCTIONS MUST BE FOLLOWED FOR PREPARATION AND INSTALLATION.
3. EACH KIT CONTAINS MATERIALS FOR SPLICING ONE PHASE OF CABLE.

**VOLUME 7 - C.O.E.  
DESIGN & CONSTRUCTION  
STANDARDS**

REVIEWED BY STANDARDS COMMITTEE: 2013-01-22  
 DRAFTED BY: R. LAWRIE  
 DESIGNED BY: A. RAHMAN  
 SCALE: N. T. S.  
 DATE REVISED: 2017-06-01



**STRAIGHT SPLICE  
FOR XLPE/EPR CABLES**

STANDARD NO. **63 00 07 00 48 009** PAGE NO. 1 / 2

20170602 10:22 r lawrie



ITEM	PART DESCRIPTION	STOCK No.	QTY.
1	KIT SPLICE - AS PER TABLE	AS REQ'D	1
	FOR 500/750 MCM AL/CU OR 750 MCM CU LC CABLE	28465	
	FOR 4/0 AL 15 kV CABLE OR #1, 1/0 AL 25 kV	28463	
	FOR #2, 1/0, 4/0 AL 15 kV CABLE	28422	
	FOR 750 MCM 25 kV CABLE	54580	
	FOR #2 STRANDED 15 kV CABLE	49972	
	FOR 1/0 AL 25 kV CABLE	07285	
	FOR 500 MCM CU TRIPLEX 15 kV CABLE	15233	
	FOR 1/0 AL 15 kV CABLE	32925	
	FOR 500 MCM AL 15/25 kV CABLE	15133	
2	MECHANICAL CONNECTOR - AS PER TABLE	AS REQ'D	1
	FOR #2 TO 250 MCM CABLE	32344	
	FOR 4/0 TO 500 MCM CABLE	32345	
3	COPPER SLEEVE - AS PER TABLE	AS REQ'D	1
	#2 AWG STRANDED	25054	
	2/0 STRANDED SHORT	25057	
4	HEAT-SHRINK - AS PER TABLE	AS REQ'D	1
	HEAT-SHRINK TUBE - 3" X 40"	26556	
	HEAT-SHRINK TUBE - 4" X 48"	21837	
5	LC ADAPTER KIT - AS PER TABLE - AS REQUIRED	28467	A/R

OBSOLETE

<b>VOLUME 7 - C.O.E. DESIGN &amp; CONSTRUCTION STANDARDS</b>		<b>STRAIGHT SPLICE FOR XLPE/EPR CABLES</b>
REVIEWED BY STANDARDS COMMITTEE: 2013-01-22		
DRAFTED BY: R. LAWRIE		
DESIGNED BY: A. RAHMAN		
SCALE: N. T. S.		
DATE REVISED: 2017-06-01	STANDARD NO. <b>63 00 07 00 48 009</b>	PAGE NO. 2 / 2

20170602 10:25 r lawrie

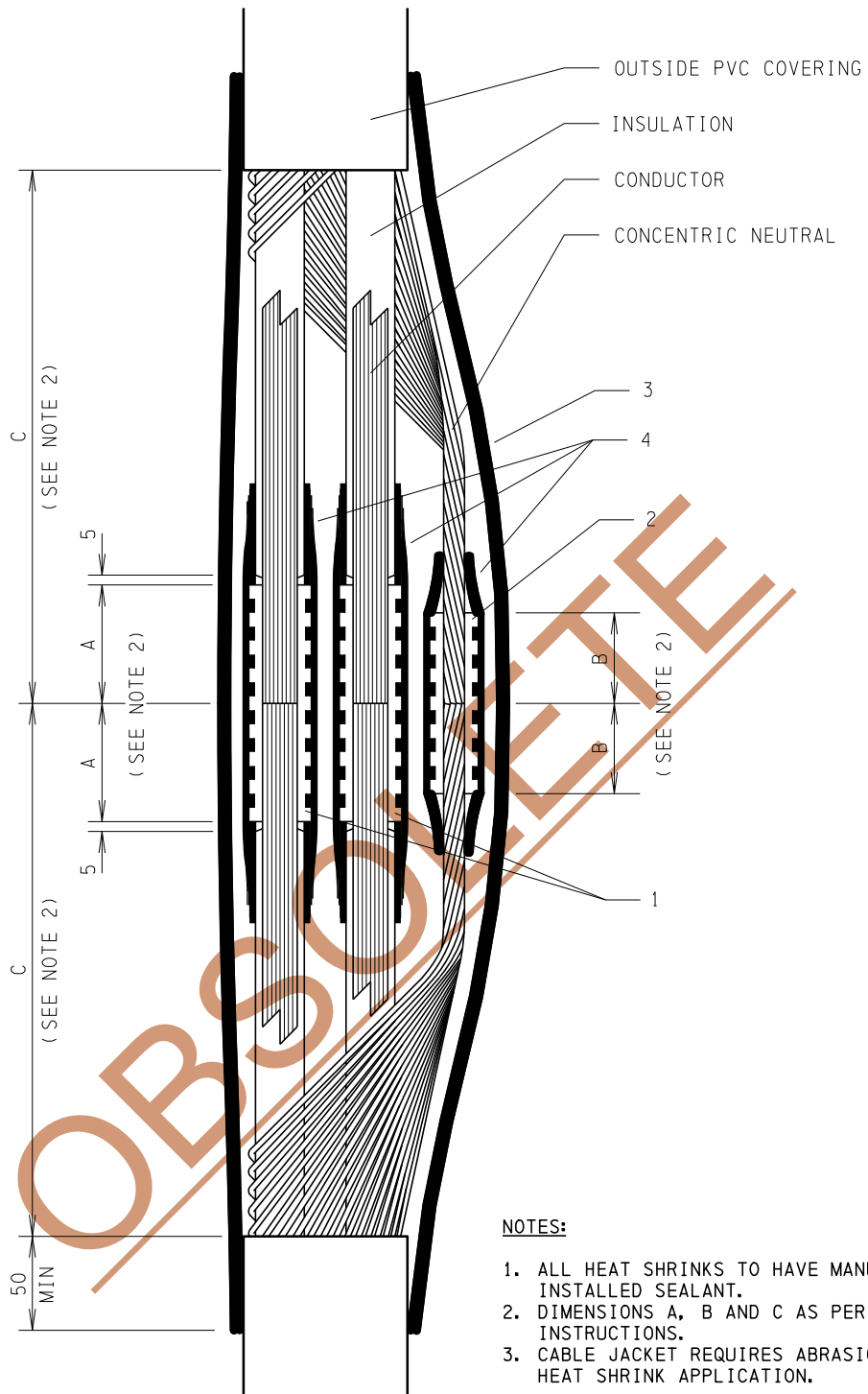

**NOTES:**

1. ALL HEAT SHRINKS TO HAVE MANUFACTURER INSTALLED SEALANT.
2. DIMENSIONS A, B AND C AS PER MANUFACTURER'S INSTRUCTIONS.
3. CABLE JACKET REQUIRES ABRASION PRIOR TO HEAT SHRINK APPLICATION.

ALL DIMENSIONS IN MILLIMETERS UNLESS OTHERWISE SPECIFIED.

**VOLUME 7 - C.O.E.  
DESIGN & CONSTRUCTION  
STANDARDS**

REVIEWED BY STANDARDS  
COMMITTEE: 2014-07-08

DRAFTED BY: R. LAWRIE

DESIGNED BY: A. RAHMAN

SCALE: N. T. S.

DATE REVISED: 2014-08-26



**SECONDARY SERVICE  
CABLE SPLICE  
600 V 2/C XLPE AL CN**

STANDARD NO.

66 00 07 08 48 001

PAGE NO.

1 / 2

20170602 16:37 r lawrie

ITEM	PART DESCRIPTION	STOCK No.	QTY.
1	SLEEVE - UG SECONDARY	AS REQ'D	2
	FOR 4/0 AL CABLE	66109	
	FOR 2/0 AL CABLE	25073	
	FOR 1/0 AL CABLE	10081	
	FOR #2 AL CABLE	25045	
	FOR #4 AL CABLE	25044	
2	SLEEVE - NEUTRAL WIRE	AS REQ'D	1
	FOR 4/0 AL CABLE	25057	
	FOR 2/0 AL CABLE	25054	
	FOR 1/0 AL CABLE	25054	
	FOR #2 AL CABLE	57104	
	FOR #4 AL CABLE	53278	
3	TUBING HEAT SHRINK	AS REQ'D	1
	FOR 4/0 AL CABLE	26556	
	FOR 2/0 AL CABLE	25229	
	FOR 1/0 AL CABLE	25229	
	FOR #2 AL CABLE	25229	
	FOR #4 AL CABLE	25229	
4	TUBING HEAT SHRINK	AS REQ'D	3
	FOR 4/0 AL CABLE	77813	
	FOR 2/0 AL CABLE	77813	
	FOR 1/0 AL CABLE	77813	
	FOR #2 AL CABLE	25227	
	FOR #4 AL CABLE	25227	

OBSOLETE

<b>VOLUME 7 - C.O.E. DESIGN &amp; CONSTRUCTION STANDARDS</b>	
REVIEWED BY STANDARDS COMMITTEE:	2014-07-08
DRAFTED BY:	R. LAWRIE
DESIGNED BY:	A. RAHMAN
SCALE:	N. T. S.
DATE REVISED:	2014-08-26



<b>SECONDARY SERVICE CABLE SPLICE 600 V 2/C XLPE AL CN</b>	
STANDARD NO.	PAGE NO.
66 00 07 08 48 001	2 / 2

20170602 16:38 R Lawrie

## COMPRESSION DIE REFERENCE CHART

CONDUCTOR SIZE		COLOUR	BURNDY				HUSKIE	
CU	AL		Y-35		MD-6		U-DIE CAT. NO.	W-DIE CAT. NO.
			CAT. NO.	INDEX NO.	CAT. NO.	INDEX NO.		
8 AWG		RED	U8 CRT	49	W8 CVT	49	-	-
6 AWG		BLUE	U5 CRT	7	W5 CVT	7	HT41 AT	HT58 AT
	8 AWG	BLUE	U8 CABT	374	X8 CART	374	HT41 GL	-
4 AWG		GREY	U4 CRT	8	W4 CVT	8	HT41 AU	HT58 AU
	6 AWG	GREY	U6 CABT	346	W161	161	HT41 GE	HT58 BX
2 AWG		BROWN	U2 CRT	10	W2 CVT	10	HT41 AW	HT58 AW
1 AWG		GREEN	U1 CRT	11	W1 CVT	11	HT41 AX	HT58 AX
	4 AWG	GREEN	U4 CABT	375	W162	162	HT41 GM	HT58 BZ
1/0		PINK	U25 RT	12	W25 VT	12	HT41 AY	HT58 AY
	2 AWG	PINK	U2 CABT	348	W239	239	HT41 GF	HT58 DH
	1 AWG	GOLD	U1 CART	471	W163	163	-	HT58 CB
2/0		BLACK	U26 RT	13	W26 VT	13	HT41 AZ	HT58 AZ
3/0		ORANGE	U27 RT	14	W27 VT	14	HT41 BA	HT58 BA
	1/0	TAN	U25 ART	296	W241	241	HT41 EX	HT58 DK
4/0		PURPLE	U28 RT	15	W28 VT	15	HT41 BC	HT58 BC
	2/0	OLIVE	U26 ART	297	W245	245	HT41 EY	HT58 DP
250 MCM		YELLOW	U29 RT	16	-	-	HT41 BE	-
	3/0	RUBY	U27 ART	467	W166	166	HT41 GW	HT58 CF
300 MCM		WHITE	U30 RT	17	-	-	HT41 BF	
	4/0	WHITE	U28 ART	298	W660	660	HT41 EZ	
350 MCM		RED	U31 RT	18			HT41 BJ	
	250 MCM	RED	U29 ART	324			HT41 FW	
400 MCM		BLUE	U32 RT	19			HT41 BK	
	300 MCM	BLUE	U30 ART	470			HT41 GZ	
500 MCM		BROWN	U34 RT	20			HT41 BL	
	350 MCM	BROWN	U31 ART	299			HT41 FA	
600 MCM		GREEN	U36 RT	22			HT41 BM	
	400 MCM	GREEN	U32 ART	472			HT41 HH	
	500 MCM	PINK	U34 ART	300			HT41 FB	P-DIE CAT. NO.
750 MCM		BLACK	U39 RT	24	P39 RT	24	HT41 BP	HT61 BP
	600 MCM	BLACK	U36 ART	473	-	-	HT41 HG	-
	750 MCM	RED	U39 ART2	936	P39 ART	301	HT41 LJ	HT61 FC
	1000 MCM	GOLD			P40 ART	474		HT61 HJ
	1500 MCM	BROWN			P44 ART	302		HT61 FD
1000 MCM		ORANGE			P40 RT	25		HT61 BR
1500 MCM		WHITE			P44 RT	27		HT61 BU

**NOTES:** 1. Y-35 OR HT41 IS A U-DIE HYDRAULIC CRIMP, 12 TONS. 2. MD-6 OR HT58 IS A W-DIE HAND CRIMP, 4-6 TONS. 3. Y-46 OR HT61 IS A REMOTE OPERATED CRIMP, 15 TONS.

<p style="text-align: center;"><b>VOLUME 7 - C.O.E.</b> <b>DESIGN &amp; CONSTRUCTION</b> <b>STANDARDS</b></p>		<p><b>COMPRESSION DIE</b> <b>REFERENCE CHART</b></p>
<p>REVIEWED BY STANDARDS COMMITTEE: 2014-07-08</p> <p>DRAFTED BY: R. LAWRIE</p> <p>DESIGNED BY: A. RAHMAN / M. MIX</p> <p>SCALE: N. T. S.</p> <p>DATE REVISED: 2014-06-17</p>	<p>STANDARD NO. <b>63 00 07 00 20 001</b></p>	<p>PAGE NO. 1 / 1</p>

20170601 15:30 r lawrie

# 4.0m X 4.0m RIGHT-OF-WAY REQUIREMENT

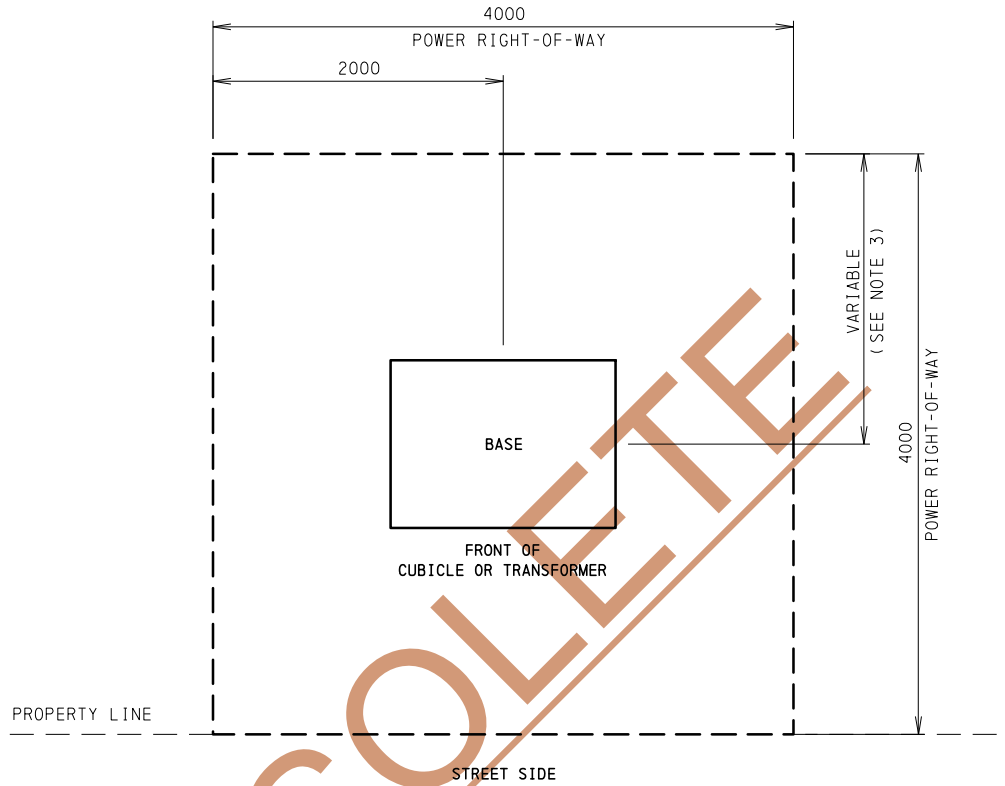

OBSOLETE

**NOTES:**

1. HOTSTICK OPERATIONS REQUIRE 3.0m UNOBSTRUCTED ACCESS.
2. FRONT OF CUBICLE OR TRANSFORMER TO FACE STREET.
3. REFER TO SWITCHING CUBICLE BASE AND TRANSFORMER BASE INSTALLATION STANDARDS FOR INSTALLATION DETAILS.
4. GUARD RAIL IS REQUIRED WHEN A CUBICLE OR TRANSFORMER IS INSTALLED ON PRIVATE PROPERTY.

ALL DIMENSIONS ARE IN MILLIMETERS (INCHES) UNLESS OTHERWISE SPECIFIED.

20170711 08:32 rlowrie 1:20

<p><b>VOLUME 7 - C.O.E. DESIGN &amp; CONSTRUCTION STANDARDS</b></p>		<p><b>RIGHT-OF-WAY REQUIREMENT FOR SINGLE PHASE SWITCHING CUBICLE, SINGLE PHASE TRANSFORMER OR 3 PHASE TRANSFORMER</b></p>
<p>REVIEWED BY STANDARDS COMMITTEE: 2013-05-28</p> <p>DRAFTED BY: P. MANN</p> <p>DESIGNED BY: B. O'CALLAGHAN</p> <p>SCALE: N. T. S.</p> <p>DATE REVISED: 2013-05-21</p>		<p>STANDARD NO. <b>60 00 07 00 12 001</b></p> <p>PAGE NO. 1 / 1</p>

# 4.0m X 6.0m RIGHT-OF-WAY REQUIREMENT

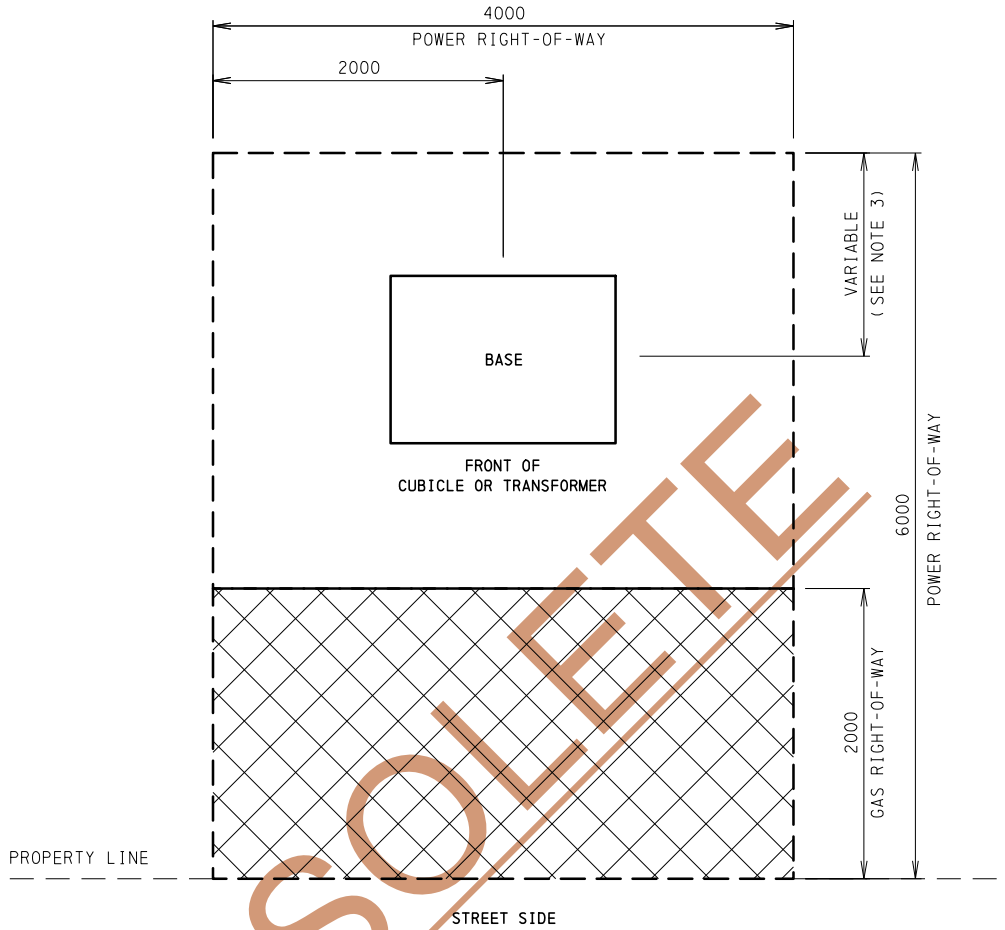

**NOTES:**

1. HOTSTICK OPERATIONS REQUIRE 3.0m UNOBSTRUCTED ACCESS.
2. FRONT OF CUBICLE OR TRANSFORMER TO FACE STREET.
3. REFER TO SWITCHING CUBICLE BASE AND TRANSFORMER BASE INSTALLATION STANDARDS FOR INSTALLATION DETAILS.
4. GUARD RAIL IS REQUIRED WHEN A CUBICLE OR TRANSFORMER IS INSTALLED ON PRIVATE PROPERTY.

ALL DIMENSIONS ARE IN MILLIMETERS (INCHES) UNLESS OTHERWISE SPECIFIED.

**VOLUME 7 - C.O.E.  
DESIGN & CONSTRUCTION  
STANDARDS**

REVIEWED BY STANDARDS  
COMMITTEE: 2013-MM-28

DRAFTED BY: P. MANN

DESIGNED BY: C. O'CALLAGHAN

SCALE: N. T. S.

DATE REVISED: 2013-05-22



**RIGHT-OF -WAY REQUIREMENT  
FOR SINGLE PHASE SWITCHING  
CUBICLE, SINGLE PHASE  
TRANSFORMER OR 3 PHASE  
TRANSFORMER WITH 2.0m  
GAS RIGHT-OF-WAY**

STANDARD NO.  
**60 00 07 00 12 002**

PAGE NO.  
1 / 1

20170601 15:00 r lawrie 1:20

# 4.0m X 9.0m RIGHT-OF-WAY REQUIREMENT

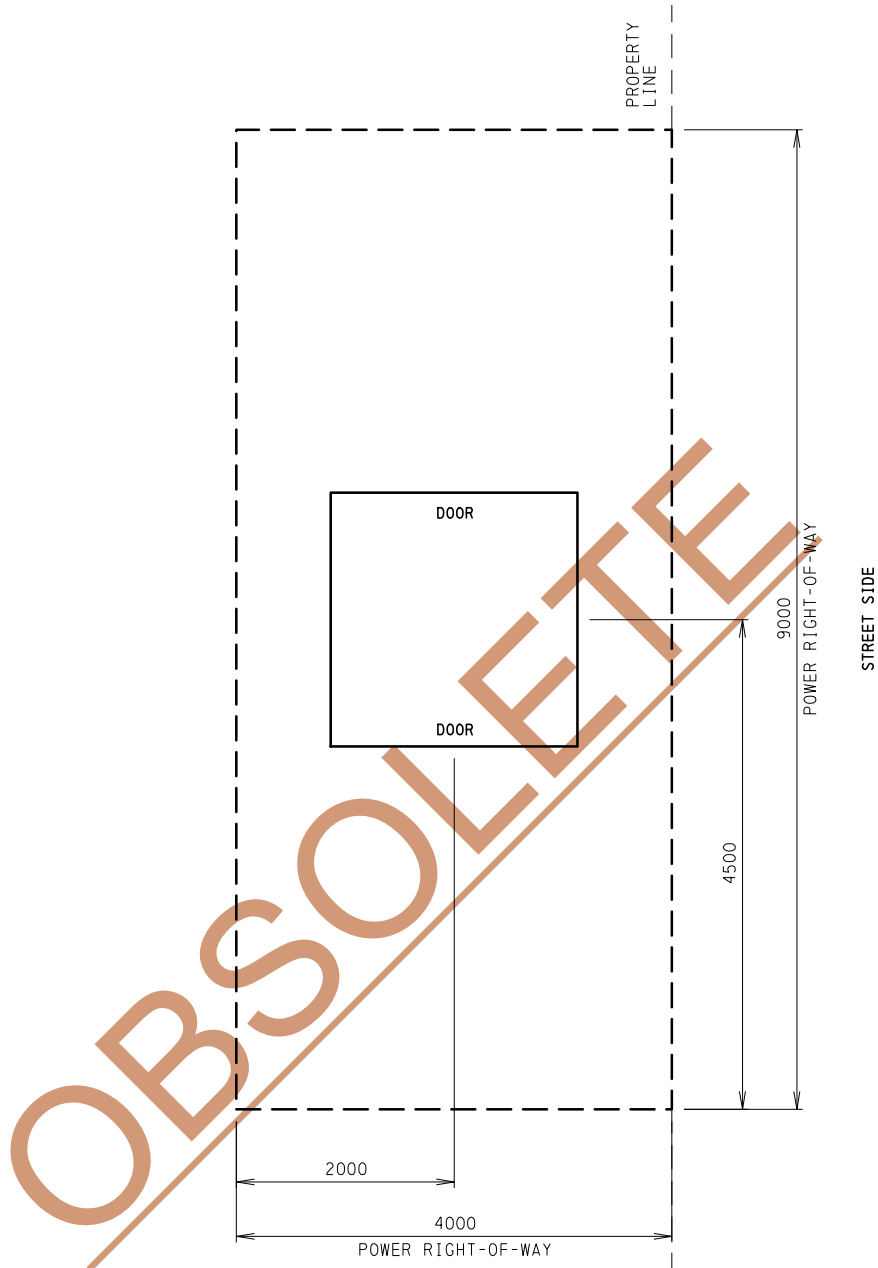

**NOTES:**

1. HOTSTICK OPERATIONS REQUIRE 3.0m UNOBSTRUCTED ACCESS.
  2. REFER TO SWITCHING CUBICLE BASE INSTALLATION STANDARD FOR INSTALLATION DETAILS.
  3. GUARD RAIL IS REQUIRED WHEN A CUBICLE IS INSTALLED ON PRIVATE PROPERTY.
- ALL DIMENSIONS ARE IN MILLIMETERS (INCHES) UNLESS OTHERWISE SPECIFIED.

20170601 15:02 rlowrie 1:15

<b>VOLUME 7 - C.O.E.</b> <b>DESIGN &amp; CONSTRUCTION</b> <b>STANDARDS</b>		<b>RIGHT-OF-WAY REQUIREMENT</b> <b>FOR</b> <b>3 PHASE SWITCHING CUBICLE</b>	
REVIEWED BY STANDARDS COMMITTEE: 2013-05-28		<b>STANDARD NO.</b> 60 00 07 00 12 005	<b>PAGE NO.</b> 1 / 1
DRAFTED BY: P. MANN			
DESIGNED BY: B. O'CALLAGHAN			
SCALE: N. T. S.			
DATE REVISED: 2013-05-22			

# 6.0m X 9.0m RIGHT-OF-WAY REQUIREMENT

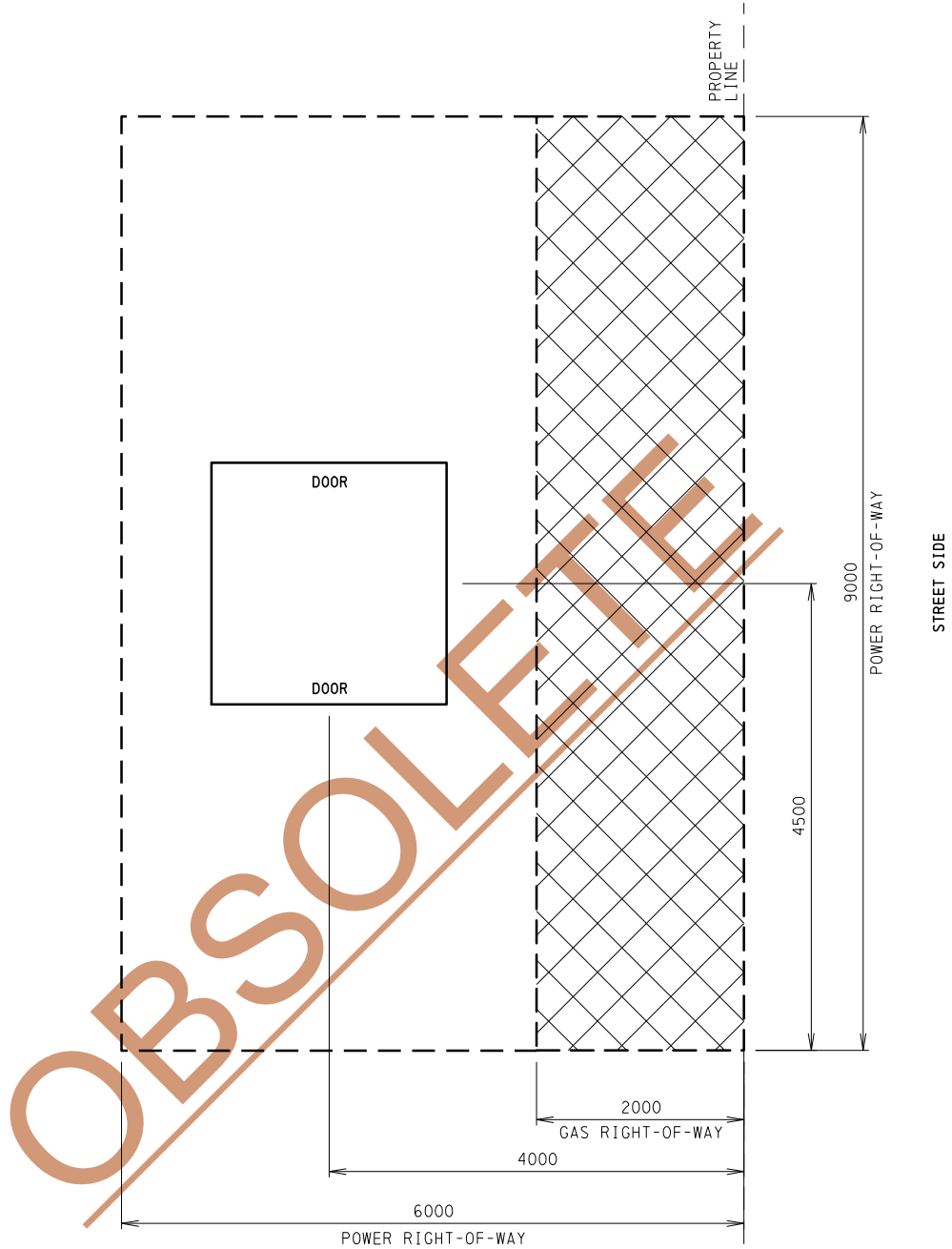

**NOTES:**

1. HOTSTICK OPERATIONS REQUIRE 3.0m UNOBSTRUCTED ACCESS.
  2. REFER TO SWITCHING CUBICLE BASE INSTALLATION STANDARD FOR INSTALLATION DETAILS.
  3. GUARD RAIL IS REQUIRED WHEN A CUBICLE IS INSTALLED ON PRIVATE PROPERTY.
- ALL DIMENSIONS ARE IN MILLIMETERS (INCHES) UNLESS OTHERWISE SPECIFIED.

20170601 15:05 r lowrie 1:15

<p><b>VOLUME 7 - C.O.E. DESIGN &amp; CONSTRUCTION STANDARDS</b></p>		<p><b>RIGHT-OF-WAY REQUIREMENT FOR 3 PHASE SWITCHING CUBICLE WITH 2.0m GAS RIGHT-OF-WAY</b></p>
<p>REVIEWED BY STANDARDS COMMITTEE: 2013-05-28</p> <p>DRAFTED BY: P. MANN</p> <p>DESIGNED BY: B. O'CALLAGHAN</p> <p>SCALE: N. T. S.</p> <p>DATE REVISED: 2013-05-22</p>		<p>STANDARD NO. <b>60 00 07 00 12 006</b></p> <p>PAGE NO. 1 / 1</p>



DIRECT BURIED CABLE

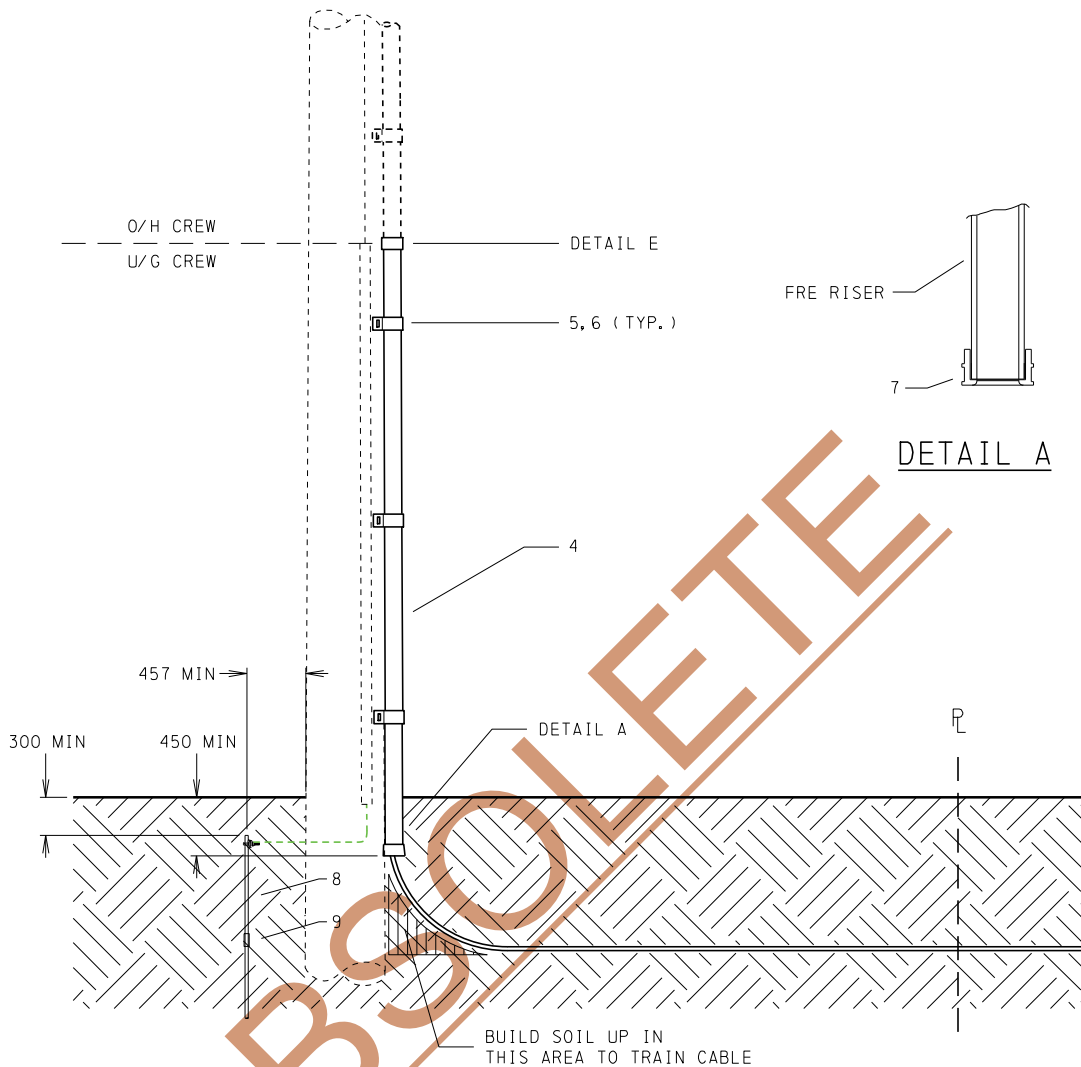

**NOTES:**

1. THE POLE RISER SHALL BE MOUNTED ON THE SIDE OF THE POLE SO AS TO MINIMIZE THE RISK OF DAMAGE FROM TRAFFIC WHENEVER POSSIBLE.
  2. ALL SUPPLY RISERS SHALL BE GROUPED TOGETHER SO AS TO NOT AFFECT CLIMBABILITY OF THE POLE.
  3. THE QUANTITY OF MATERIALS 1, 2, 3 AND 7 WILL VARY DEPENDING ON WHETHER THE U/G CONDUCTORS ARE DIRECT BURIED OR IN CONDUIT.
  4. AT LEAST 60% OF RISER-FREE CONTINUOUS CIRCUMFERENCE OF THE POLE SHALL BE MAINTAINED.
  5. FOR APPROPRIATE DIRECT BURIED CABLE TRAINING RADII SEE 63 00 07 00 47 002.
  6. INSTALL DANGER SIGN FOR DIRECT BURIED CABLE AS PER STANDARD 63 00 07 00 46 001 AS REQUIRED.
  7. FOR SECONDARY RISERS NO GROUND ROD IS REQUIRED.
  8. ADDITIONAL AND/OR DEEPER GROUND RODS MAY BE NEEDED TO ACHIEVE REQUIRED RESISTANCE OF 6 OHMS OR LESS.
- ALL DIMENSIONS IN MILLIMETERS UNLESS OTHERWISE SPECIFIED.

**VOLUME 7 - C.O.E.  
DESIGN & CONSTRUCTION  
STANDARDS**

REVIEWED BY STANDARDS  
COMMITTEE: 2014-05-20

DRAFTED BY: R. LAWRIE

DESIGNED BY: A. RAHMAN / M. MIX

SCALE: N. T. S.

DATE REVISED: 2016-08-11



**PRIMARY AND SECONDARY  
RISER INSTALLATION**

STANDARD NO.  
**66 00 07 00 37 001**

PAGE NO.  
1 / 3

20170602 15:40 r lawrie

CABLE IN CONDUIT

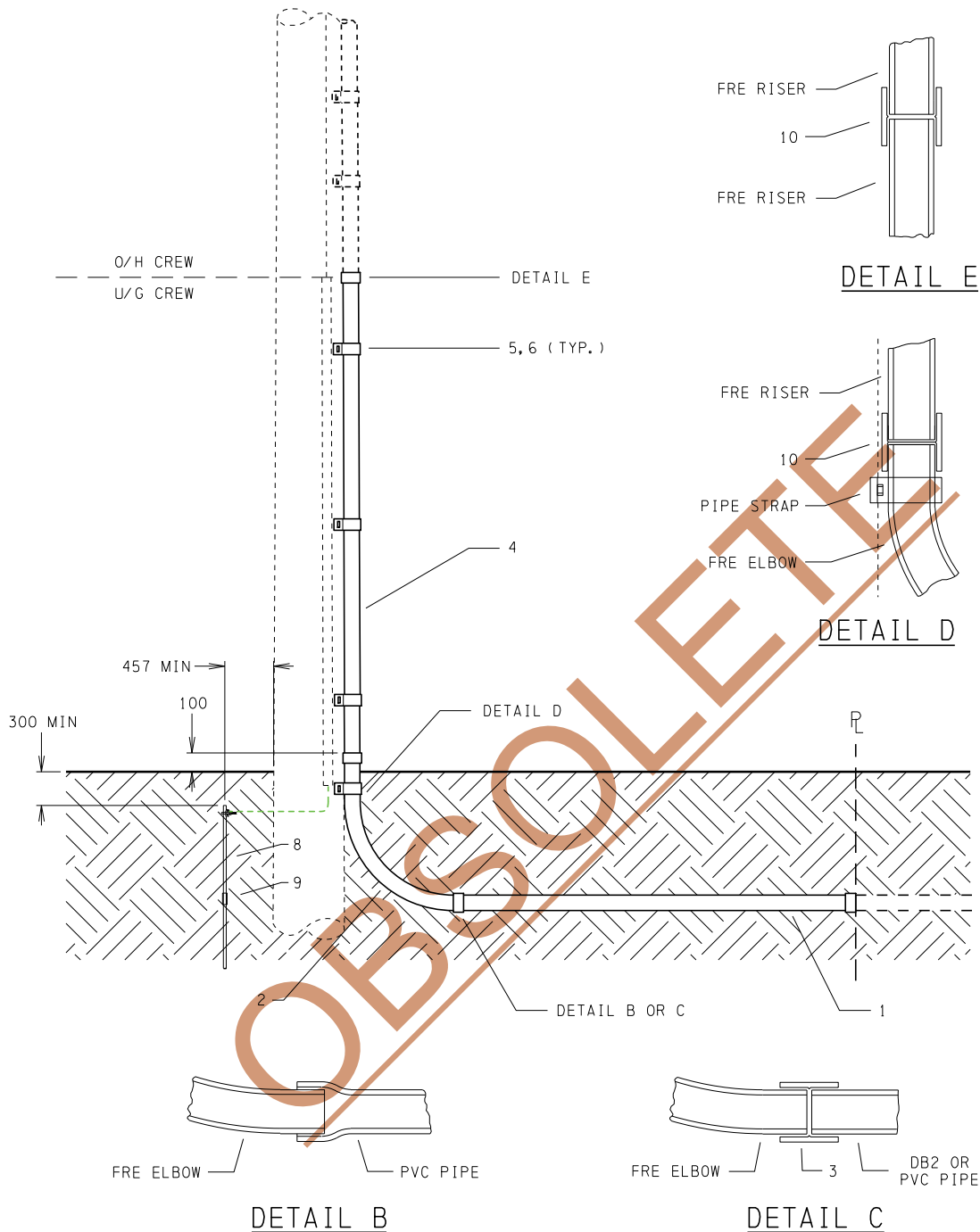

OBSOLETE

20170602 15:46 r lawrie

<b>VOLUME 7 - C.O.E. DESIGN &amp; CONSTRUCTION STANDARDS</b>	
REVIEWED BY STANDARDS COMMITTEE:	2014-05-20
DRAFTED BY:	R. LAWRIE
DESIGNED BY:	A. RAHMAN / M. MIX
SCALE:	N. T. S.
DATE REVISED:	2016-08-11



**PRIMARY AND SECONDARY  
RISER INSTALLATION**

STANDARD NO. <b>66 00 07 00 37 001</b>	PAGE NO. 2 / 3
-------------------------------------------	-------------------

ITEM	PART DESCRIPTION	STOCK No.	QTY.
1	PIPE DUCT - 20' LENGTH	AS REQ'D	A/R
	DB2 - 2"	61508	
	DB2 - 4"	53283	
	DB2 - 6"	42236	
	PVC - 4"	10083	
	PVC - 6"	10692	
2	ELBOW BEND 90 DEG	AS REQ'D	A/R
	2" FRE ( 50 mm) 24R	17764	
	4" FRE ( 100 mm) 36R	17668	
	6" FRE ( 150 mm) 36R	17336	
3	COUPLING ADAPTER	AS REQ'D	A/R
	PVC TO FRE - 4"	26695	
	PVC TO FRE - 6"	34751	
	DB2 TO FRE - 2"	10220	
	DB2 TO FRE - 4"	38916	
	DB2 TO FRE - 6"	10284	
4	FRE RISER 3 m LENGTH	AS REQ'D	1
	2" DUCT	93081	
	4" DUCT	93083	
	6" DUCT	93085	
5	STRAP PIPE - 2 HOLE	AS REQ'D	4
	2" STRAP	33690	
	4" STRAP	37667	
	6" STRAP	13264	
6	FASTENERS	AS REQ'D	8
	NAIL COMMON STEEL 4" LONG (FOR 2" STRAP)	VMI	
	SCREW - DRILL/TAP (FOR FIBERGLASS OR STEEL POLE)	12279	
	SCREW LAG GALV 3/8" x 4"	65457	
7	END BELL COLLAR	AS REQ'D	A/R
	PVC - 2"	17790	
	PVC - 4"	20574	
	PVC - 6"	20889	
8	ROD GROUNDING 5/8" x 5'	17288	2
9	COUPLER - GROUND ROD	17289	1
10	COUPLING FRE	AS REQ'D	A/R
	FRE TO FRE - 2"	17765	
	FRE TO FRE - 4"	17672	
	FRE TO FRE - 6"	17338	

**VOLUME 7 - C.O.E.  
DESIGN & CONSTRUCTION  
STANDARDS**

REVIEWED BY STANDARDS  
COMMITTEE: 2014-05-20

DRAFTED BY: R. LAWRIE

DESIGNED BY: A. RAHMAN / M. MIX

SCALE: N. T. S.

DATE REVISED: 2016-08-11



**PRIMARY AND SECONDARY  
RISER INSTALLATION**

STANDARD NO.

66 00 07 00 37 001

PAGE NO.

3 / 3

20170602 15:44 r lawrie

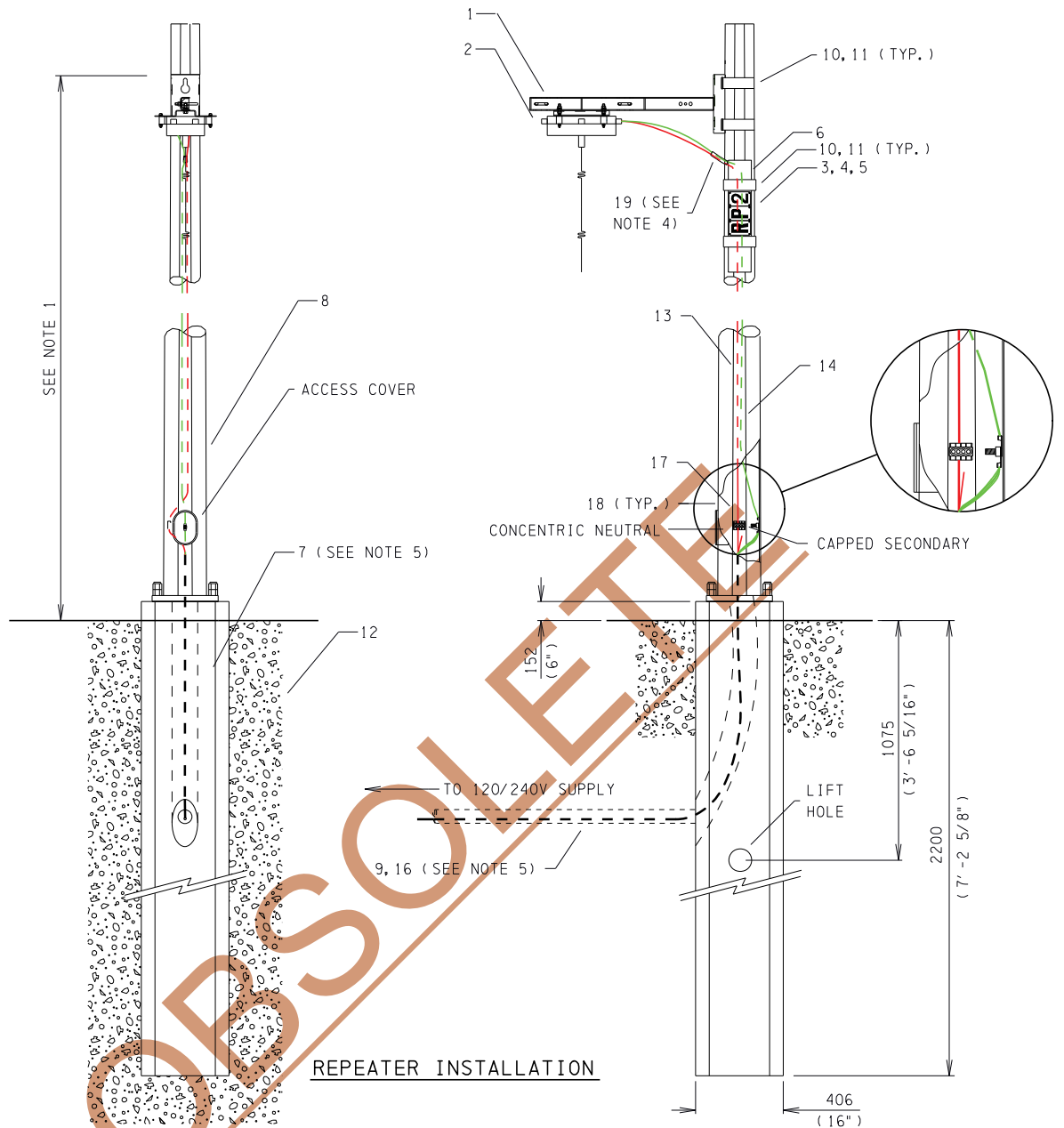

**NOTE:**

1. MOUNTING HEIGHT AND REPEATER DIRECTION ARE DEPENDENT ON COMMUNICATION REQUIREMENTS. CONTACT D.A ENGINEERING IF NOT SPECIFIED ON WORK ORDER.
2. A CONTINUOUS 120 VOLT SECONDARY SERVICE IS REQUIRED WHEN THE RADIO/REPEATER IS INSTALLED.
3. METAL POLE TO BE INSTALLED A MIN. OF 3.0m (10FT) AWAY FROM THE EDGE OF THE NEAREST ROADWAY.
4. DRILL UPPER ACCESS HOLE AS PER CABLE SIZE, SEAL ACCESS HOLE TO PREVENT WATER LEAKAGE.
5. WHEN INSTALLING PRECAST CONCRETE BASE ENSURE THE FINAL POSITION OF THE SIDE OPENING FACES DESIRED CONDUIT DIRECTION.

ALL DIMENSIONS ARE IN MILLIMETERS (INCHES) UNLESS OTHERWISE SPECIFIED.

**VOLUME 7 - C.O.E.  
DESIGN & CONSTRUCTION  
STANDARDS**

REVIEWED BY STANDARDS  
COMMITTEE: 2013-02-12  
DRAFTED BY: R. LAWRIE  
DESIGNED BY: A. RAHMAN  
SCALE: N. T. S.  
DATE REVISED: 2017-06-01



**REPEATER INSTALLATION  
ON STEEL POLE**

STANDARD NO.  
**66 00 07 01 07 001**

PAGE NO.  
1 / 3

REPEATER

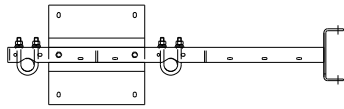

TOP VIEW

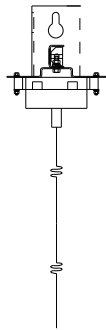

FRONT VIEW

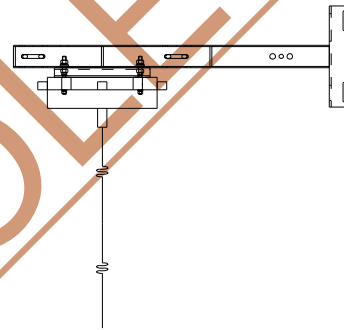
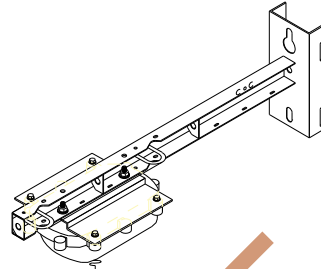

SIDE VIEW

OBSOLETE

VOLUME 7 - C.O.E.  
DESIGN & CONSTRUCTION  
STANDARDS

REVIEWED BY STANDARDS  
COMMITTEE: 2013-02-12

DRAFTED BY: R. LAWRIE

DESIGNED BY: A. RAHMAN

SCALE: N. T. S.

DATE REVISED: 2017-06-01



REPEATER INSTALLATION  
ON STEEL POLE

STANDARD NO.

66 00 07 01 07 001

PAGE NO.

2 / 3

ITEM	PART DESCRIPTION FOR REPEATER INSTALLATION	STOCK No.	QTY.
1	BRACKET REPEATER RADIO - DISTRIBUTION AUTOMATION	10353	1
2	REPEATER RADIO - DISTRIBUTION AUTOMATION	10369	1
3	TAG LETTER R - 3" BLACK ON YELLOW	10150	1
4	TAG LETTER P - 3" BLACK ON YELLOW	10145	1
5	TAG NUMBERS - SEE STANDARD 6100070020105 FOR TAG NUMBER DETAILS	FIELD ASSIGNED	A/R
6	TAG HOLDER 3" x 7 TAGS WIDE	31845	1
7	BASE LIGHTPOLE PRECAST CONCRETE	14765	1
8	POLE STREETLIGHT 35' GALV.	13491	1
9	PIPE DUCT	AS REQ'D	A/R
	DB2 - 2"	61508	
	PVC FLEX - 2"	69387	
10	STRAPPING STAINLESS STEEL 3/4"	VMI	4
11	BUCKLE STRAPPING STAINLESS STEEL 3/4"	VMI	4
12	ROAD CRUSH - 3/4"	N/A	A/R
13	WIRE ELECTRICAL #10 STRANDED COPPER RW90 (BLACK)	42938	A/R
14	WIRE ELECTRICAL #10 STRANDED COPPER RW90 (WHITE)	45201	A/R
15	TUBE SHRINK COLD 0.4" -0.82" x 8" LONG	56472	1
16	CABLE SECONDARY 4 AWG 600 VOLT 2/C XLPE ALUMINUM	30216	A/R
17	CONNECTOR INSULATED UNITAP #4 - #14 (TAMS STOCK)	13776	1
18	CONNECTOR TERMINAL #6 x 1/2" HOLE	78625	2

OBSOLETE

20170602 16:18 r lawrie

<p align="center"><b>VOLUME 7 - C.O.E.</b> <b>DESIGN &amp; CONSTRUCTION</b> <b>STANDARDS</b></p>		<p><b>REPEATER INSTALLATION</b> <b>ON STEEL POLE</b></p>	
<p>REVIEWED BY STANDARDS COMMITTEE: 2013-02-12</p>		STANDARD NO.	PAGE NO.
<p>DRAFTED BY: R. LAWRIE</p>		66 00 07 01 07 001	3 / 3
<p>DESIGNED BY: A. RAHMAN</p>			
<p>SCALE: N. T. S.</p>			
<p>DATE REVISED: 2017-06-01</p>			

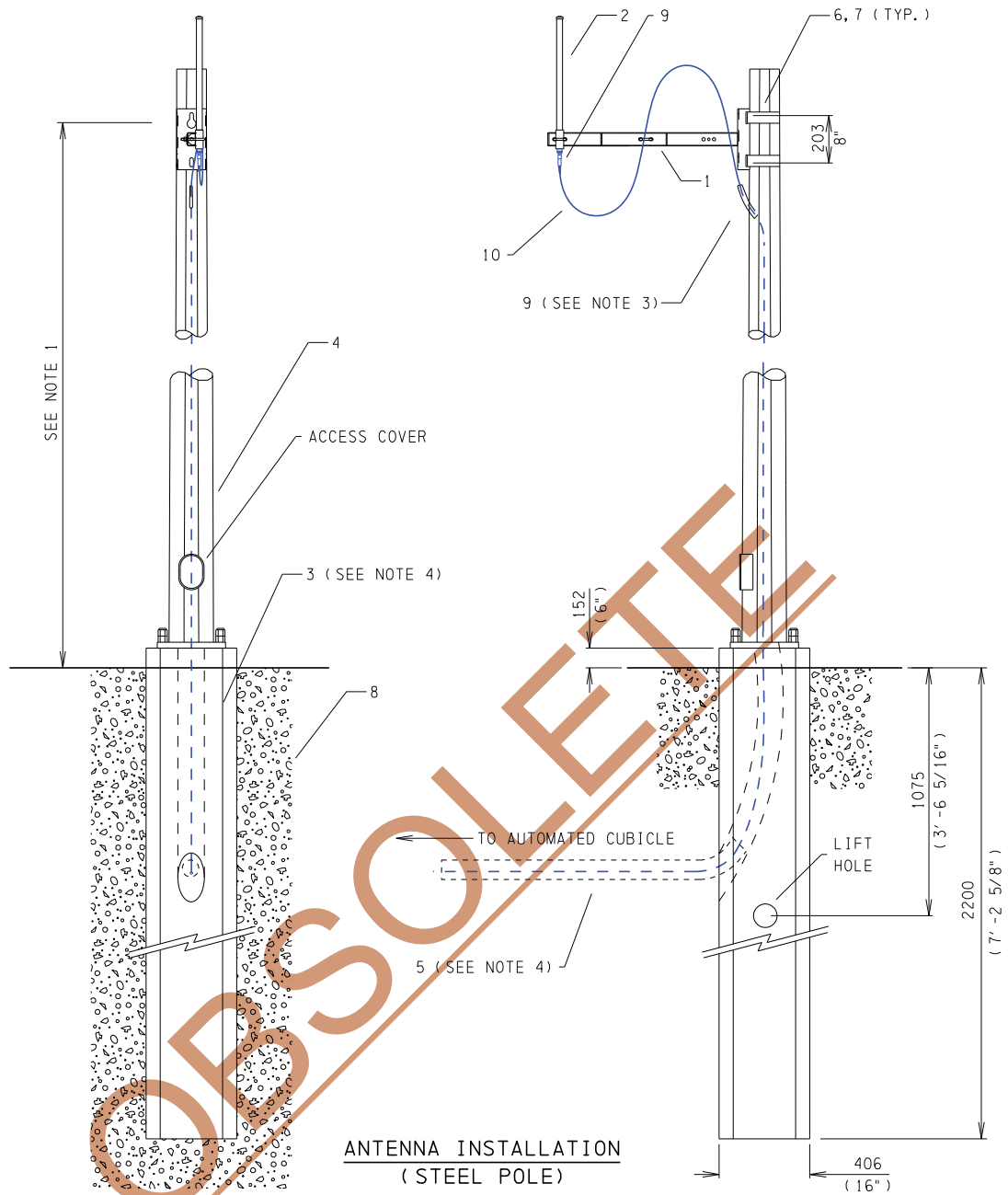

**ANTENNA INSTALLATION  
(STEEL POLE)**

**NOTE:**

1. MOUNTING HEIGHT AND ANTENNA DIRECTION ARE DEPENDANT ON COMMUNICATION REQUIREMENTS. CONTACT D. A. ENGINEERING IF NOT SPECIFIED ON THE WORK ORDER.
2. METAL POLE TO BE INSTALLED A MINIMUM OF 3.0m (10 ft) FROM THE EDGE OF THE NEAREST ROADWAY.
3. DRILL UPPER ACCESS HOLE AS PER CABLE SIZE, SEAL ACCESS HOLE TO PREVENT WATER LEAKAGE.
4. WHEN INSTALLING PRECAST CONCRETE BASE ENSURE THE FINAL POSITION OF THE SIDE OPENING FACES DESIRED CONDUIT DIRECTION.

ALL DIMENSIONS ARE IN MILLIMETERS (INCHES) UNLESS OTHERWISE SPECIFIED.

**VOLUME 7 - C.O.E.  
DESIGN & CONSTRUCTION  
STANDARDS**

REVIEWED BY STANDARDS  
COMMITTEE: 2013-02-12

DRAFTED BY: R. LAWRIE

DESIGNED BY: A. RAHMAN

SCALE: N. T. S.

DATE REVISED: 2017-06-01



**ANTENNA INSTALLATION  
ON STEEL POLE**

STANDARD NO.

**66 00 07 00 07 001**

PAGE NO.

1 / 3

20170602 15:10 r lawrie 1:35

ANTENNA

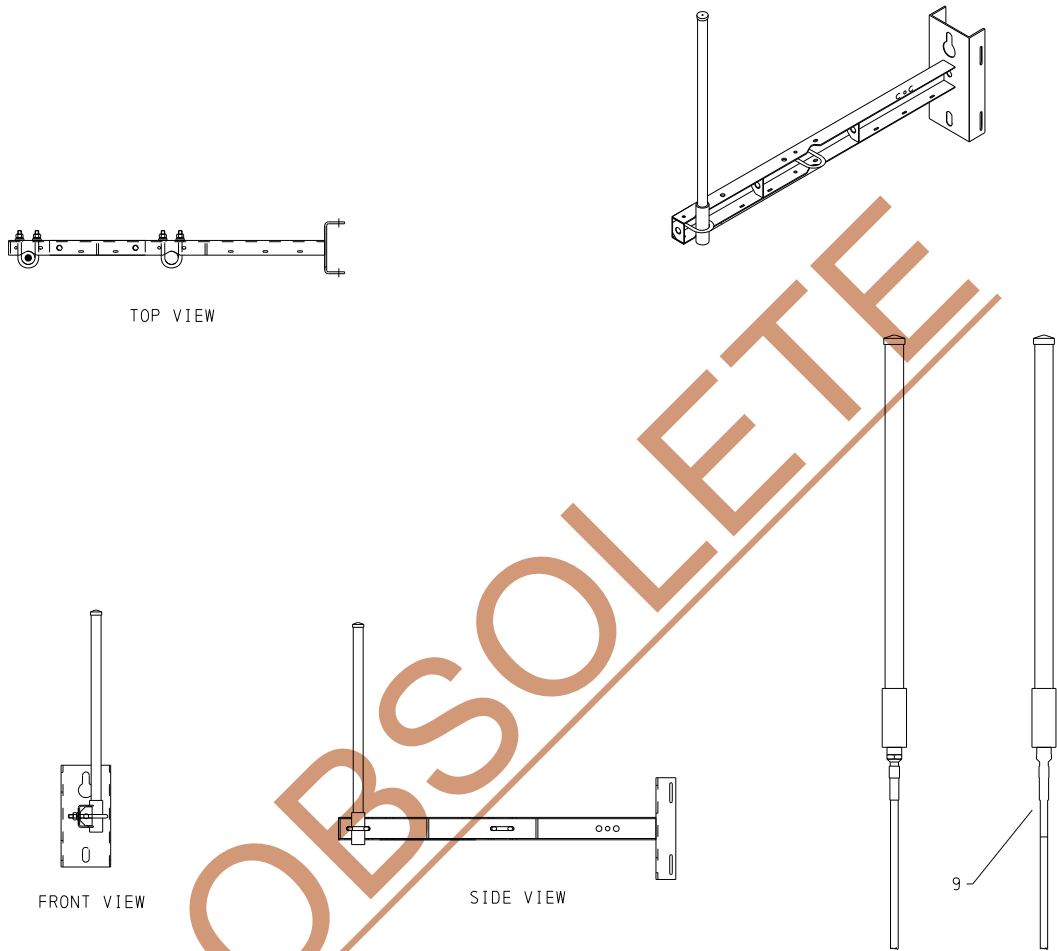

OBSOLETE

NOTE CON'T:

- 5. ITEM \*9 (COLD SHRINK) TO BE PLACED FLUSH WITH THE UNDERSIDE OF THE ANTENNA, OVER THE CABLE ONLY. MOISTURE DRAIN HOLES ON THE BOTTOM OF THE ANTENNA SHOULD NOT BE COVERED.

VOLUME 7 - C.O.E.  
DESIGN & CONSTRUCTION  
STANDARDS

REVIEWED BY STANDARDS COMMITTEE:	2013-02-12
DRAFTED BY:	R. LAWRIE
DESIGNED BY:	A. RAHMAN
SCALE:	N. T. S.
DATE REVISED:	2017-06-01



ANTENNA INSTALLATION  
ON STEEL POLE

STANDARD NO.	PAGE NO.
66 00 07 00 07 001	2 / 3

20170602 15:16 r lawrie





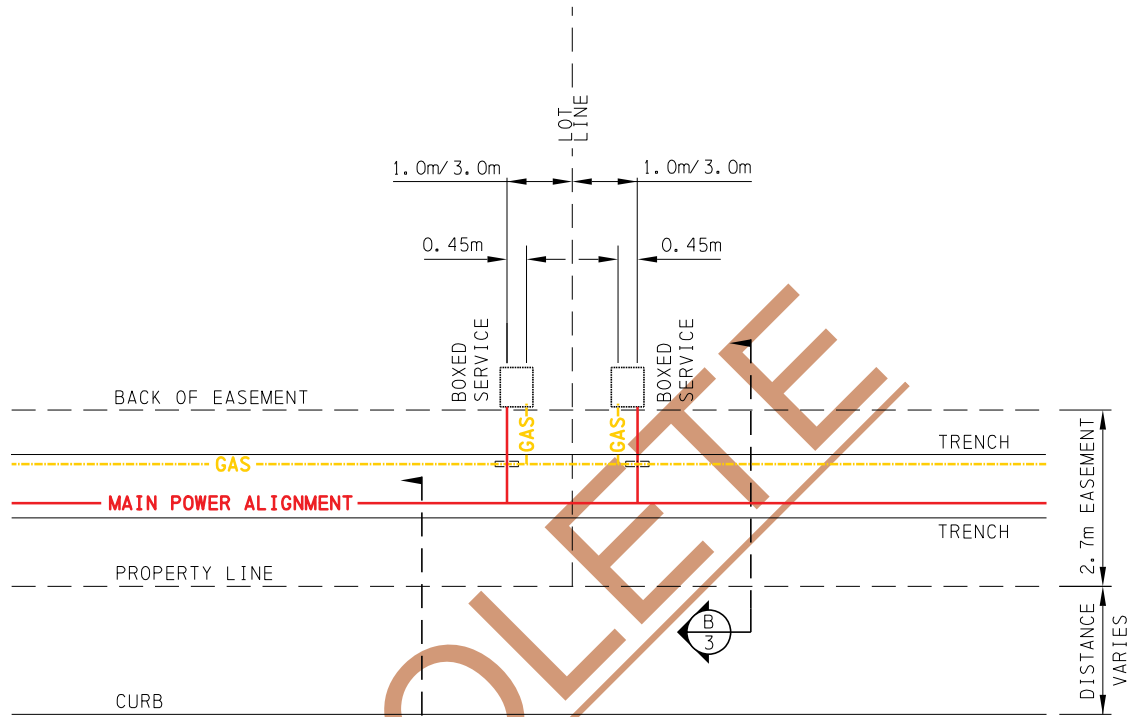

SHARED POWER TRENCH  
SCALE: N.T.S.

OBSOLETE

20170706 15:44 r lawrie

<b>VOLUME 7 - C.O.E. DESIGN &amp; CONSTRUCTION STANDARDS</b>		<b>TYPICAL SHARED POWER TRENCH</b>
REVIEWED BY STANDARDS COMMITTEE: 2017-05-26		
DRAFTED BY: R. LAWRIE		
DESIGNED BY: B. O'CALLAGHAN		
SCALE: N. T. S.		
DATE REVISED: 2017-07-06	STANDARD NO. <span style="color: green;">66 00 07 00 46 001</span>	PAGE NO. 1 / 3

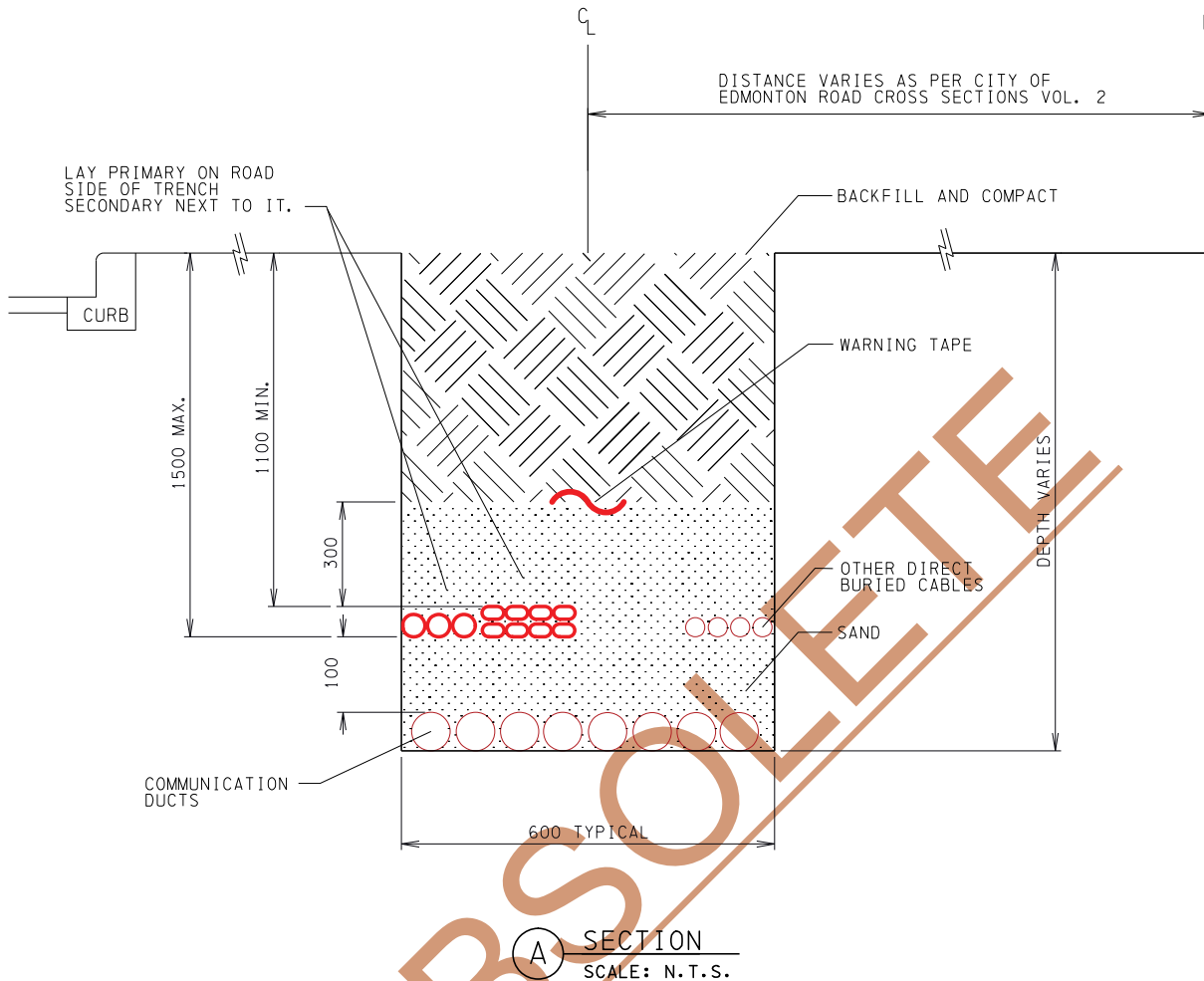

**NOTES:**

1. COMMUNICATION DUCTS PLACED IN BOTTOM OF TRENCH SUBJECT TO THE AGREEMENT OF THE PARTIES INVOLVED. DIRECT BURIED COMMUNICATION CABLES ARE NOT ALLOWED TO BE PLACED BELOW SUPPLY CIRCUITS.
2. TRENCH DEPTH AND WIDTH VARIES DEPENDING ON THE NUMBER OF COMMUNICATION DUCTS.
3. TRENCH DEEPER IF GAS CROSSES THE POWER TRENCH (MAX. DEPTH TO BOTTOM OF CABLE IS 1.5 METERS).
4. 100 mm OF SAND OVER COMMUNICATIONS DUCTS.
5. MINIMUM COVER OVER POWER CABLE IS 1.1 METERS.
6. 300 mm OF SAND OVER DIRECT BURIED CABLE.
7. BACKFILL AND COMPACT TO THE CITY OF EDMONTON CONSTRUCTION STANDARDS VOLUME 2. NO FILLCRETE ALLOWED OVER DIRECT BURIED CABLE. IN SOME ALIGNMENTS THE TRENCH IS UNDER A SIDEWALK OR PATH.
8. GAS IS IN A SEPERATE TRENCH (MINIMUM 1.0 METER SEPERATION).

ALL DIMENSIONS IN MILLIMETERS (INCHES) UNLESS OTHERWISE SPECIFIED.

**VOLUME 7 - C.O.E.  
DESIGN & CONSTRUCTION  
STANDARDS**

REVIEWED BY STANDARDS  
COMMITTEE: 2017-05-26

DRAFTED BY: R. LAWRIE

DESIGNED BY: B. O'CALLAGHAN

SCALE: N. T. S.

DATE REVISED: 2017-07-06



**TYPICAL SHARED POWER TRENCH**

STANDARD NO.

66 00 07 00 46 001

PAGE NO.

2 / 3



# TYPICAL MARKER BALL INSTALLATIONS

## PIPE STUB

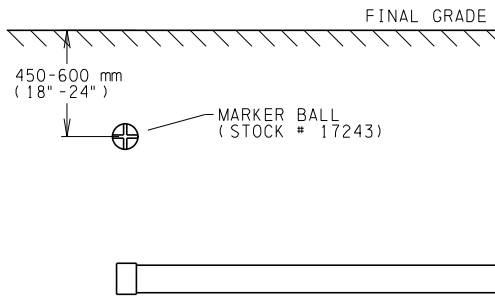

## PIPE BEND

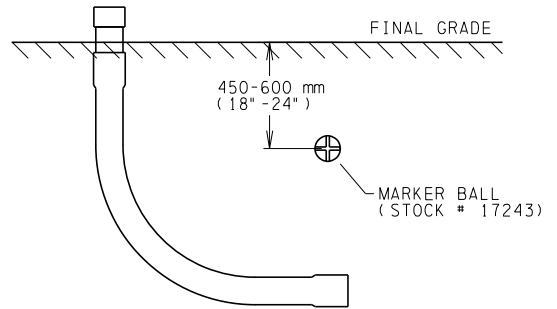

## CABLE SPLICE

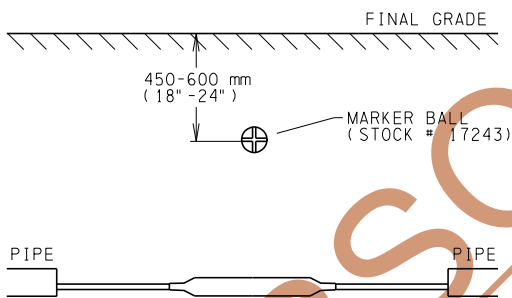

• PLACE MARKER BALLS AT ALL SPLICE PITS FOR CABLE IN PIPE AS WELL AS DIRECT BURIED CABLE

## ROAD/RAIL CROSSING

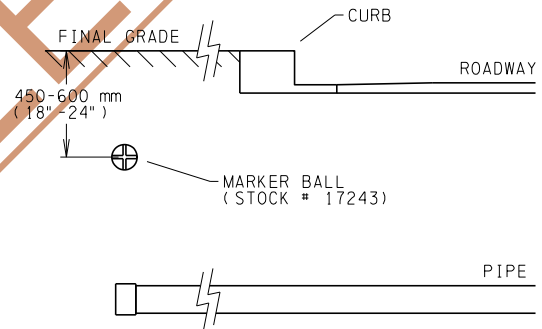

• PLACE MARKER BALLS ABOVE SPARE PIPES ON ROAD/RAIL CROSSINGS

**NOTES:**

1. MARKER BALL SHALL BE PLACED DIRECTLY OVER THE ASSET TO BE MARKED.
2. DEPTH OF BALL MUST BE 450 - 600 mm (18" - 24") BELOW FINAL FINISHED GRADE.
3. MARKER BALL DOES NOT REQUIRE ANY PARTICULAR ORIENTATION WHEN BURIED.
4. MARKER BALLS SHOULD BE PLACED AT BOTH ENDS OF A ROAD/RAIL CROSSING.

**VOLUME 7 - C.O.E.  
DESIGN & CONSTRUCTION  
STANDARDS**

REVIEWED BY STANDARDS  
COMMITTEE: 2014-04-08

DRAFTED BY: R. LAWRIE

DESIGNED BY: A. RAHMAN

SCALE: N. T. S.

DATE REVISED: 2014-06-12



**UNDERGROUND MARKER BALL  
INSTALLATION**

STANDARD NO.  
**63 00 07 00 17 001**

PAGE NO.  
1 / 1

20170601 15:15 r lawrie

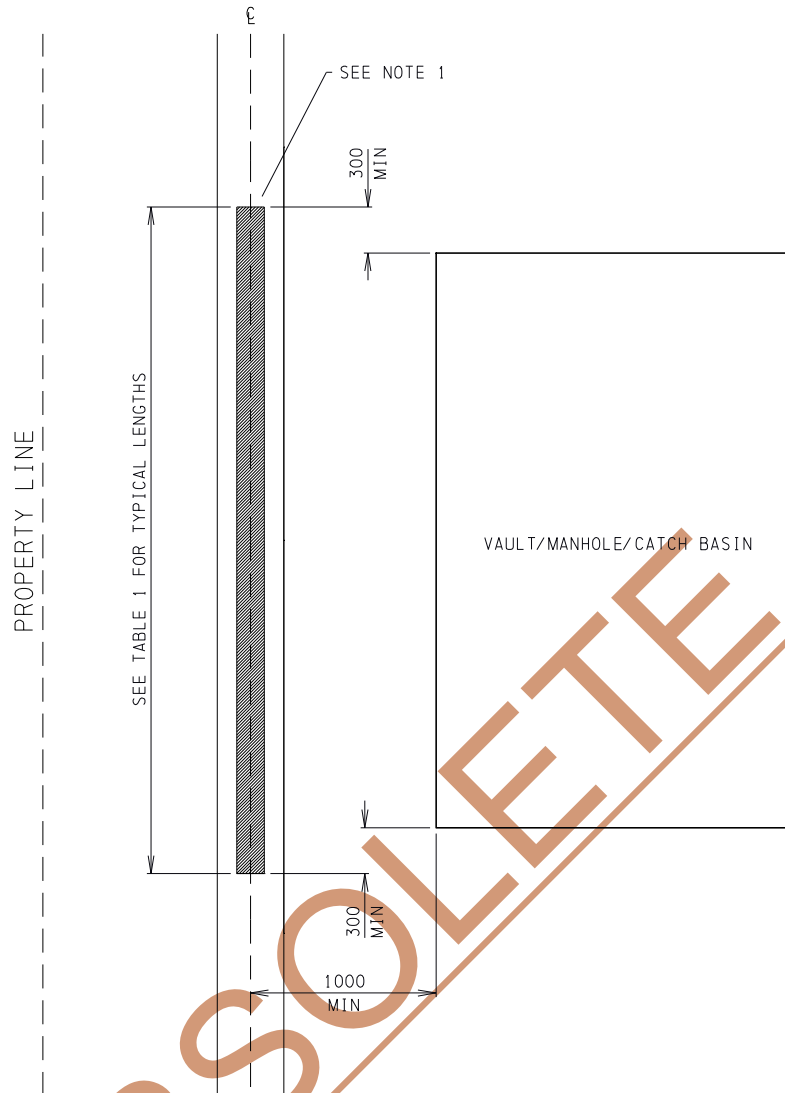

MECHANICAL PROTECTION PAST VAULT/MANHOLE/CATCH BASIN  
SCALE: N.T.S.

**NOTES:**

1. MECHANICAL PROTECTION IS REQUIRED WHEN A DIRECT BURIED CABLE:
  - a) PASSES UNDERNEATH OR WITHIN 1 m OF A PRECAST BASE OR GROUND GRID.
  - b) IS WITHIN 3 m OF VAULTS, CATCH BASINS, OR MANHOLES.
  - c) IS WITHIN 3 m OF A HYDRANT.
2. ANY REDUCTION TO THE MINIMUM ALLOWABLE CLEARANCE IN THIS STANDARD REQUIRES FURTHER ENGINEERING ANALYSIS.
3. EITHER WOOD TROUGHING OR SCHEDULE 40 PVC PIPE WITH BELL ENDS ARE ACCEPTABLE FORMS OF MECHANICAL PROTECTION.
4. TROUGHS SHOULD BE PLACED BETWEEN PROPERTY LINES AND VAULTS WHERE ACCESS TO POWER TRENCH AFTER INSTALLATION OF THE VAULT IS RESTRICTED.

ALL DIMENSIONS IN MILLIMETERS ( INCHES ) UNLESS OTHERWISE SPECIFIED.

20170602 15:58 r lawrie

<b>VOLUME 7 - C.O.E.</b> <b>DESIGN &amp; CONSTRUCTION</b> <b>STANDARDS</b>		<b>MECHANICAL PROTECTION</b> <b>FOR REDUCED CLEARANCE</b> <b>DIRECT BURIED CABLES</b>	
REVIEWED BY STANDARDS COMMITTEE: 2016-06-17		STANDARD NO.	PAGE NO.
DRAFTED BY: R. LAWRIE		66 00 07 00 46 005	1 / 4
DESIGNED BY: M. MIX			
SCALE: N. T. S. DATE REVISED: 2016-12-07			

ROAD  
BLVD

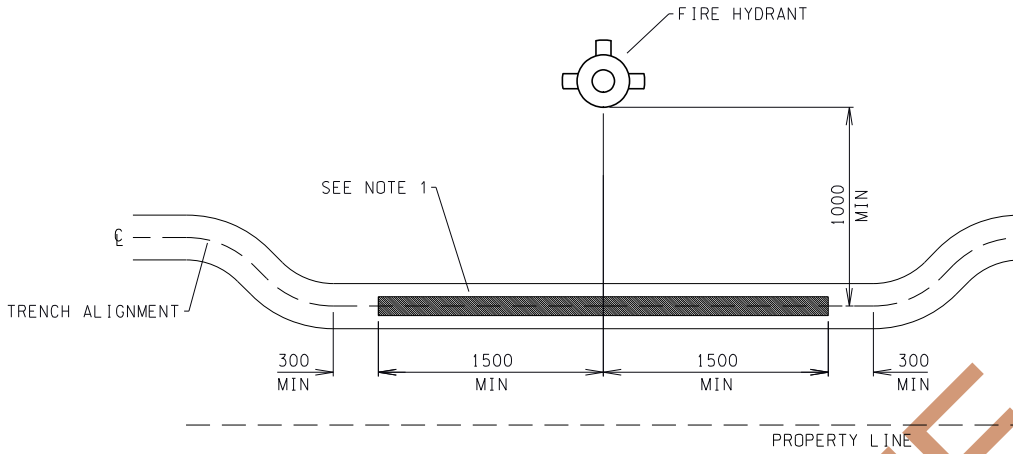

MECHANICAL PROTECTION PAST HYDRANT  
SCALE: N.T.S.

ROAD  
BLVD

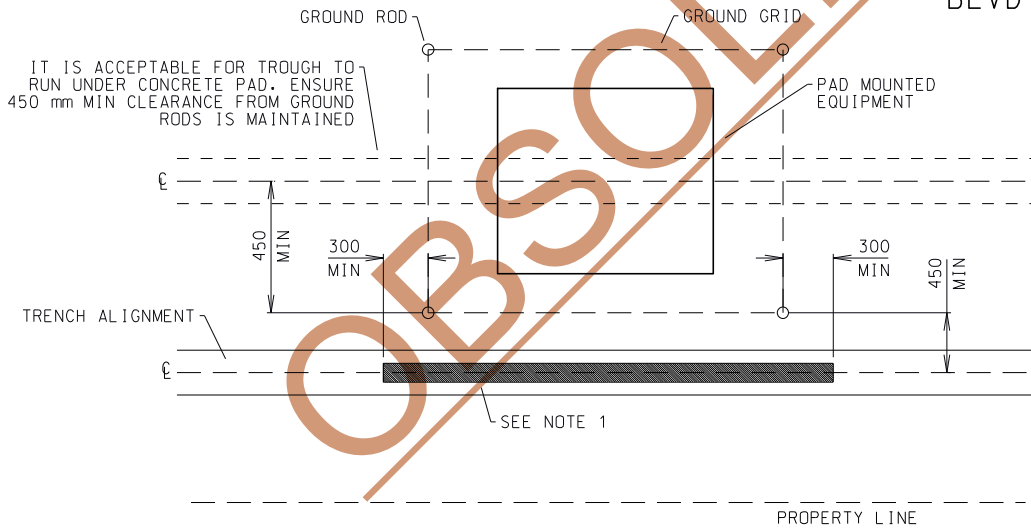

MECHANICAL PROTECTION PAST GROUND GRID  
SCALE: N.T.S.

VOLUME 7 - C.O.E.  
DESIGN & CONSTRUCTION  
STANDARDS

REVIEWED BY STANDARDS  
COMMITTEE: 2016-06-17

DRAFTED BY: R. LAWRIE

DESIGNED BY: M. MIX

SCALE: N. T. S.

DATE REVISED: 2016-12-07



MECHANICAL PROTECTION  
FOR REDUCED CLEARANCE  
DIRECT BURIED CABLES

STANDARD NO.

66 00 07 00 46 005

PAGE NO.

2 / 4

TABLE 1

TYPICAL LENGTHS FOR MECHANICAL PROTECTION		
TROUGH PAST	DESCRIPTION	TYPICAL LENGTH
FIRE HYDRANT	-	10' (3048 mm)
GROUND GRID	1-PHASE TRANSFORMER/CUBICLE	14' (4267 mm)
	3-PHASE TRANSFORMER/CUBICLE	16' (4877 mm)
VAULT/MANHOLE/ CATCH BASIN	SMALL - 4' TO 6'	8' (2438 mm)
	MEDIUM - 8' TO 10'	12' (3658 mm)
	LARGE - 12' TO 14'	16' (4877 mm)

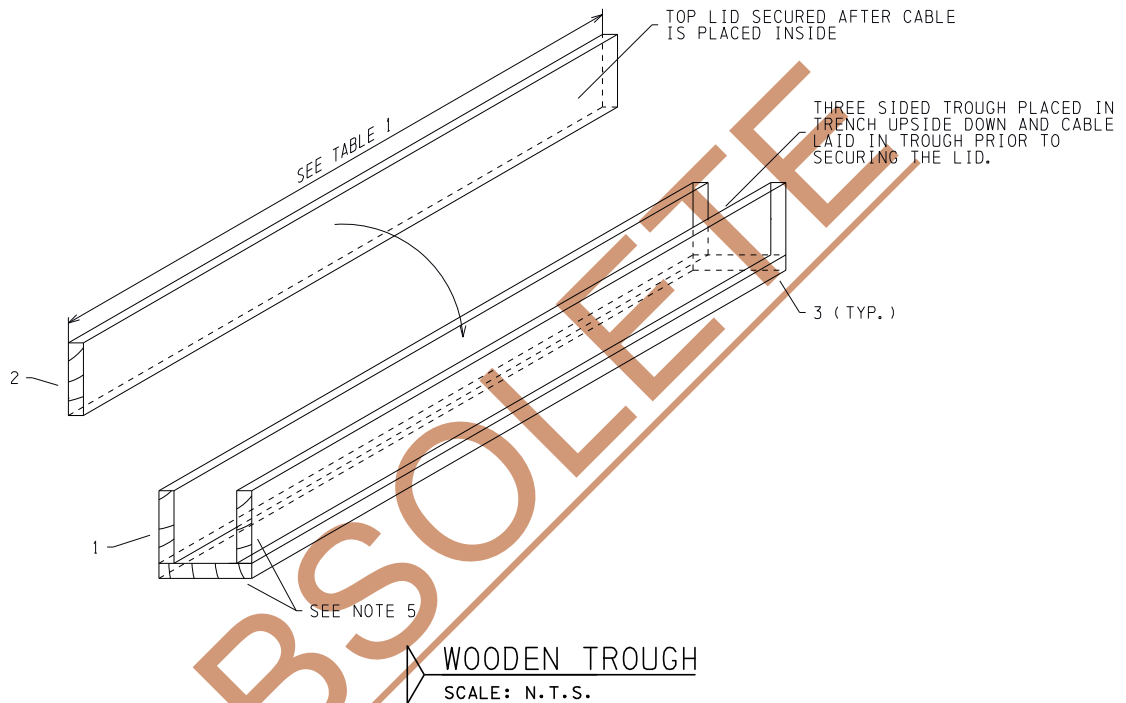

NOTES CONT'D:

5. ALL LUMBER SHALL BE PRESSURE TREATED WITH MINIMUM NOMINAL DIMENSIONS OF:
  - 2" x 10" (TOP & BOTTOM)
  - 2" x 8" (SIDES)
6. ENSURE THAT NO SCREWS OR NAILS HAVE PENETRATED THE AREA WHERE CABLE WILL BE INSTALLED.
7. EACH BOARD MUST BE CONTINUOUS FOR THE LENGTH OF THE TROUGH AND BE FREE FROM BREAKS OR SPLICES OF MULTIPLE BOARDS.
8. IF A LARGER TROUGH IS REQUIRED USE 2" X 12" BOARDS OR TWO ADJACENT TROUGHS MAY BE REQUIRED.
9. RE-TREAT CUT ENDS OF LUMBER FOUNDATION BOARDS WITH COPPER NAPHTHANATE WOOD PRESERVATIVE.
10. DO NOT ENCASE WOODEN TROUGHS IN CONCRETE.
11. STOCKED LUMBER LENGTHS ARE 8' AND 12', OTHER LUMBER LENGTHS SHALL BE PURCHASED AS REQUIRED.

ALL DIMENSIONS IN MILLIMETERS (INCHES) UNLESS OTHERWISE SPECIFIED.

**VOLUME 7 - C.O.E.  
DESIGN & CONSTRUCTION  
STANDARDS**

REVIEWED BY STANDARDS  
COMMITTEE: 2016-06-17

DRAFTED BY: R. LAWRIE

DESIGNED BY: M. MIX

SCALE: N. T. S.

DATE REVISED: 2016-12-07



**MECHANICAL PROTECTION  
FOR REDUCED CLEARANCE  
DIRECT BURIED CABLES**

STANDARD NO.  
**66 00 07 00 46 005**

PAGE NO.  
3 / 4

20170602 15:59 r lawrie





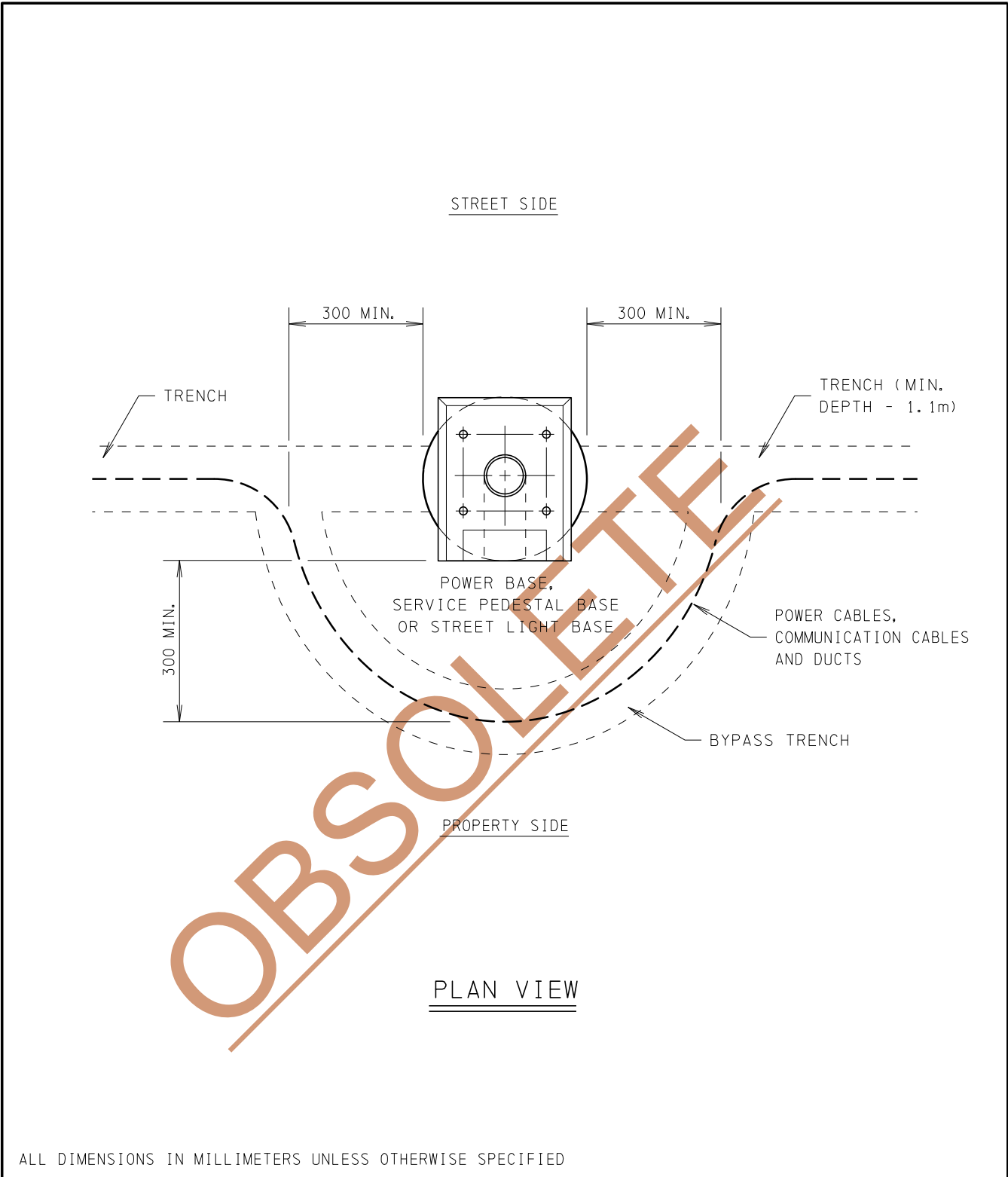

ALL DIMENSIONS IN MILLIMETERS UNLESS OTHERWISE SPECIFIED

20170602 15:56 r lawrie

<b>VOLUME 7 - C.O.E. DESIGN &amp; CONSTRUCTION STANDARDS</b>	
REVIEWED BY STANDARDS COMMITTEE:	2014-07-08
DRAFTED BY:	R. LAWRIE
DESIGNED BY:	A. RAHMAN
SCALE:	N. T. S.
DATE REVISED:	2014-07-16



<b>CABLE BYPASS AT POWER BASES SERVICE PEDESTALS &amp; STREET LIGHT BASES</b>	
STANDARD NO. <b>66 00 07 00 46 004</b>	PAGE NO. 1 / 1

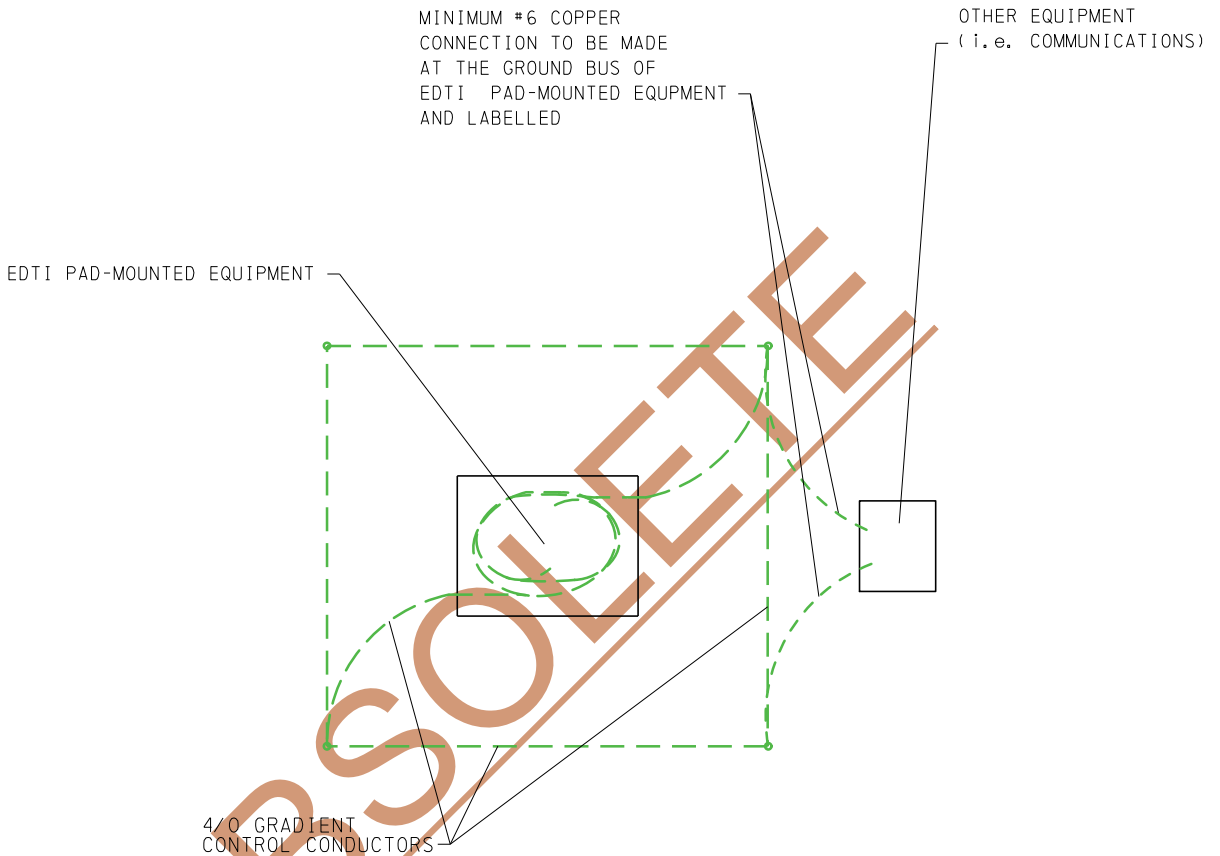

**NOTES:**

1. EDTI DOES NOT ENCOURAGE INSTALLING OTHER UTILITY'S EQUIPMENT WITHIN 3 METERS OF EDTI EQUIPMENT.
2. ANY METALLIC EQUIPMENT WITHIN 3 m OF EDTI EQUIPMENT SHALL BE BONDED TO THE EDTI EQUIPMENT GROUNDING..
3. SEE THE TRANSFORMER AND CUBICLE BASE DRAWINGS FOR GROUND GRID DETAILS OF EDTI PAD-MOUNTED EQUIPMENT.
4. #6 COPPER IS THE MINIMUM SIZE OF CONDUCTOR TO BE USED WHEN BONDING TO OTHER EQUIPMENT.
5. A DETAIL IS REQUIRED SHOWING EQUIPMENT, THEIR DIMENSIONS FROM EACH OTHER AND THE PROPOSED GROUNDING CONNECTIONS TO BE SUPPLIED BY THE PARTY REQUESTING THE CONNECTION.
6. THE COMMUNICATIONS PEDESTAL MUST BE OUTSIDE OF THE EDTI GROUND GRID.
7. THE COMMUNICATIONS PEDESTAL CANNOT BE WITHIN 3 METERS OF THE EDTI PAD-MOUNTED EQUIPMENT DOORS.

ALL DIMENSIONS IN MILLIMETERS ( INCHES ) UNLESS OTHERWISE SPECIFIED.

**VOLUME 7 - C.O.E.  
DESIGN & CONSTRUCTION  
STANDARDS**

REVIEWED BY STANDARDS  
COMMITTEE: 2017-05-26

DRAFTED BY: R. LAWRIE

DESIGNED BY: B. O'CALLAGHAN

SCALE: N. T. S.

DATE REVISED: 2017-05-03



**BONDING COMMUNICATIONS  
OR STREET LIGHTING  
FACILITIES WITHIN 3 METERS OF  
POWER DISTRIBUTION FACILITIES  
( CROSS-BONDING )**

STANDARD NO.  
**66 00 07 00 60 001**

PAGE NO.  
1 / 1

20170629 15:49 r lawrie

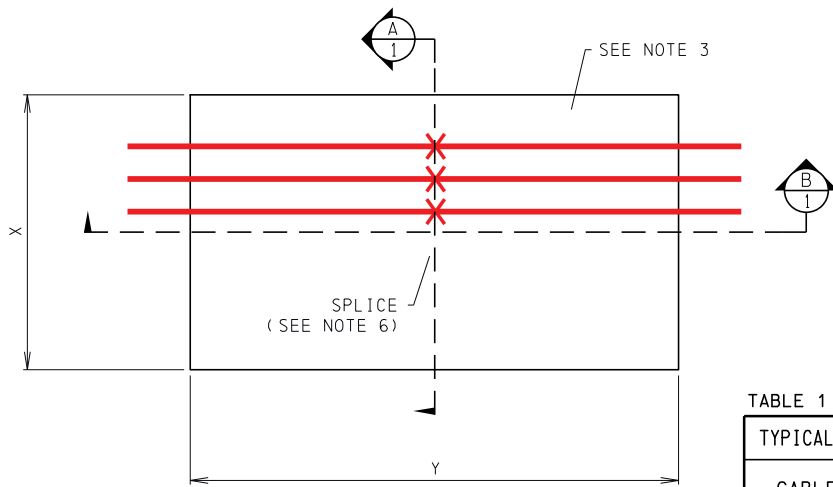

**SPLICE PIT**  
SCALE: N.T.S.

TABLE 1

TYPICAL PRIMARY CABLE SPLICE PIT DIMENSIONS			
CABLE RANGE	X (m) MIN	Y (m) MIN	Y (m) * EXTENDED
#2 - 4/0	1.2	2.5	4.0
250 - 750	1.5	3.0	4.5

\* IF PRIMARY CABLES ARE MIXED IN WITH OTHER UTILITIES

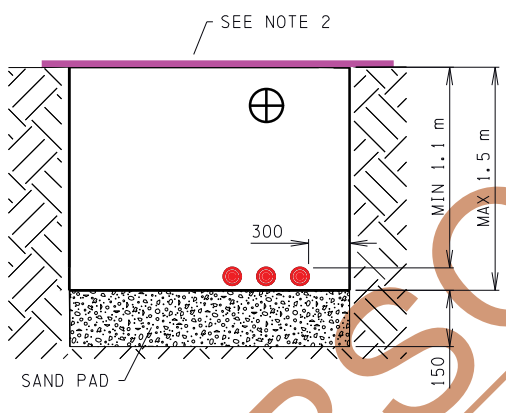

**A SECTION**  
SCALE: N.T.S.

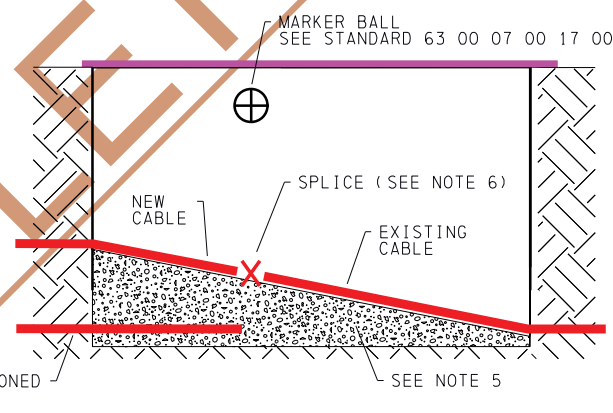

**B SECTION**  
SCALE: N.T.S.

**NOTES:**

1. ALL SPLICE PITS SHALL MEET ALBERTA OH&S EXCAVATING & TUNNELING REGULATIONS.
2. OPEN SPLICE PITS MUST BE FULLY COVERED IN ACCORDANCE WITH EPCOR WORK PRACTICE EX06 - SECURING EXCAVATIONS.
3. IF POSSIBLE THE PIT SHALL BE EXCAVATED SUCH THAT THE CABLES ARE ON ONE SIDE OF THE PIT FOR EASE OF SPLICING.
4. ALL SPLICE PITS MUST HAVE EASE OF ACCESS FOR TRADES CREWS TO ENTER AND EXIT.
5. WHEN ELEVATIONS OF THE OLD AND NEW CABLES ARE DIFFERENT, INSTALL A SAND BED TO SUPPORT THE CABLE SPLICE.
6. REFER TO STANDARD 63 00 07 00 48 009 FOR STRAIGHT SPLICES AND 63 00 07 00 48 011 FOR TRANSITION SPLICES.

ALL DIMENSIONS IN MILLIMETERS ( INCHES ) UNLESS OTHERWISE SPECIFIED.

20170711 08:22 r lawrie

<p><b>VOLUME 7 - C.O.E.</b> <b>DESIGN &amp; CONSTRUCTION STANDARDS</b></p>		<p><b>SPLICE PIT CONSTRUCTION</b></p>
<p>REVIEWED BY STANDARDS COMMITTEE: 2016-06-17</p> <p>DRAFTED BY: R. LAWRIE</p> <p>DESIGNED BY: M. MIX</p> <p>SCALE: N. T. S.</p> <p>DATE REVISED: 2016-11-09</p>	<p>STANDARD NO. <b>63 00 07 00 46 005</b></p>	<p>PAGE NO. 1 / 2</p>

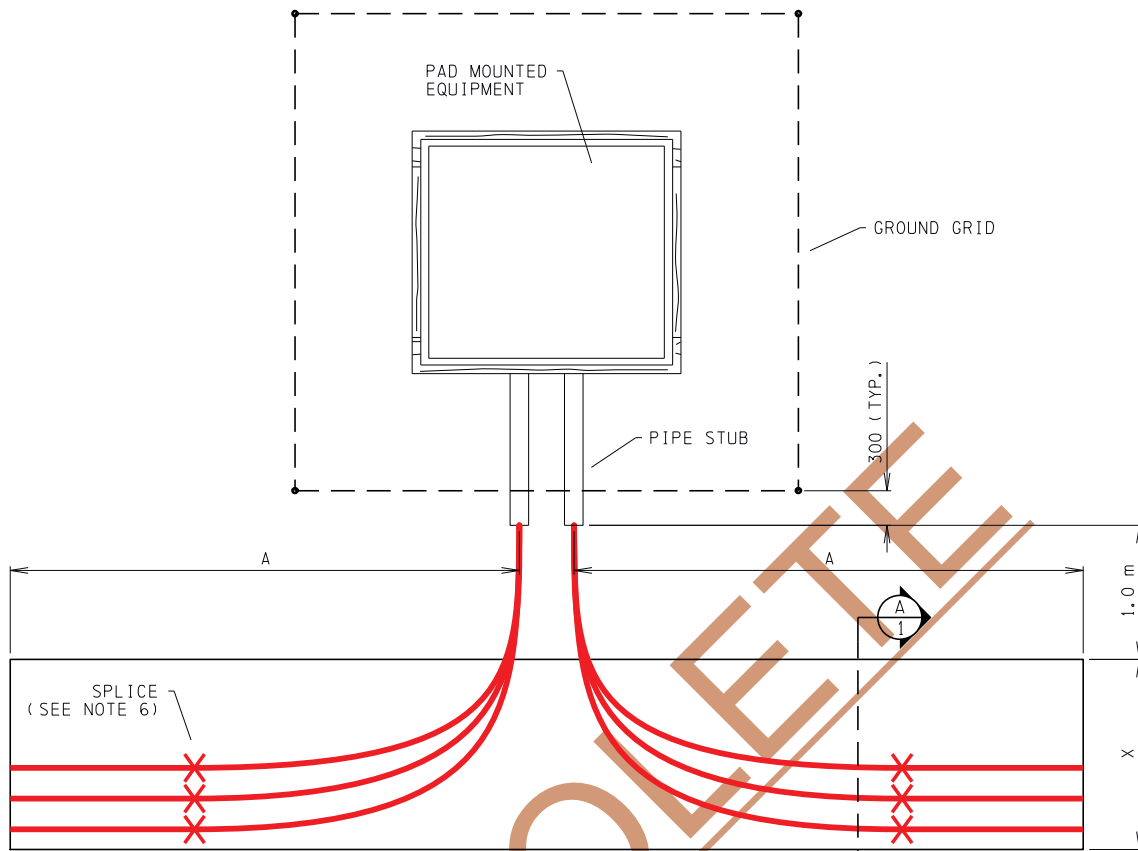

▶ SPLICE PITS IN FRONT OF PAD MOUNTED EQUIPMENT  
SCALE: N.T.S.

TABLE 2

SPLICE PIT DIMENSIONS FOR PAD MOUNTED EQUIPMENT		
CABLE RANGE	X (m) MIN	A (m) MIN **
#2 - 4/0	1.2	3.5
250 - 750	1.5	4.0

\* ENSURE THE PIT EXCAVATION CONTINUES 1 m PAST ANY EXISTING CABLE SPLICES.

ALL DIMENSIONS IN MILLIMETERS (INCHES) UNLESS OTHERWISE SPECIFIED.

VOLUME 7 - C.O.E.  
DESIGN & CONSTRUCTION  
STANDARDS

REVIEWED BY STANDARDS  
COMMITTEE: 2016-06-17

DRAFTED BY: R. LAWRIE

DESIGNED BY: M. MIX

SCALE: N. T. S.

DATE REVISED: 2016-11-09



SPLICE PIT  
CONSTRUCTION

STANDARD NO.

63 00 07 00 46 005

PAGE NO.

2 / 2

20170711 08:25 r.lawrie

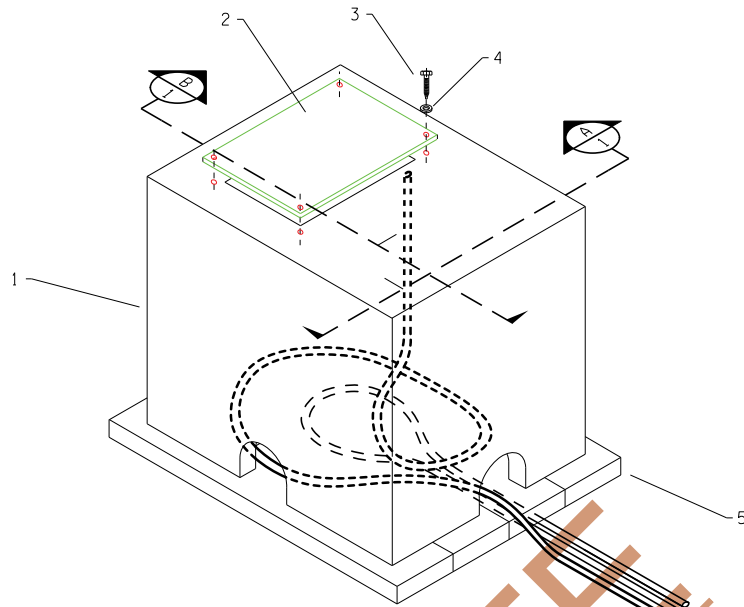

ISOMETRIC VIEW  
SCALE: N.T.S.

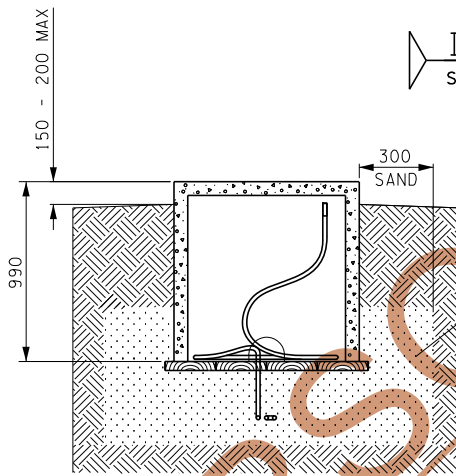

A SECTION  
SCALE: N.T.S.

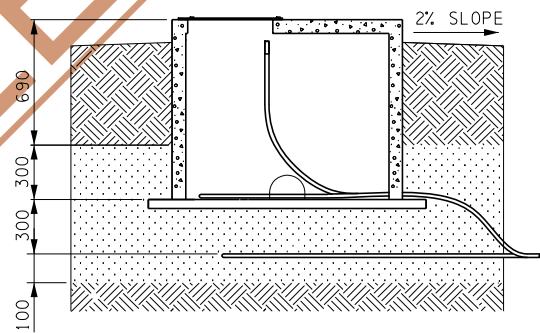

B SECTION  
SCALE: N.T.S.

**NOTES:**

1. ALL PRIMARY CABLES LOOPS AND COILS NOT PROTECTED UNDER THE TEMPORARY CONCRETE BASE MUST BE COVERED BY THE FOLLOWING IN ORDER: A 300 mm THICK LAYER OF SAND, 2"x8" (MINIMUM) PRESSURE TREATED PLANKING BUTTED TOGETHER WITHOUT VOIDS OR GAPS, AN ADDITIONAL 300 mm THICK LAYER OF SAND, AND FINALLY BACKFILLED TO GRADE AS PER SECTION A & B ON THIS DRAWING.
2. COIL 5 m OF PRIMARY IN OR UNDER BASE FOR FUTURE SPLICING, CAPPED CABLE END MUST BE ACCESSIBLE FROM BASE OPENING FOR TESTING.
3. 1/0 PRIMARY CABLES SHOULD ENTER THROUGH MOUSEHOLE AND COIL IN BASE. 500 MCM PRIMARY AND LARGER CABLES MAY BE COILED BELOW THE BASE.
4. AFTER THE PRIMARY CABLE HAS BEEN TESTED THE CABLE MUST BE RECAPPED WITH THE APPROPRIATE HEAT SHRINK CAP AS PER STANDARD 66 00 07 00 48 175.
5. THE CONCRETE BASE AND COVER PLATE ARE NOT DESIGNED TO WITHSTAND VEHICULAR LOADS.

ALL DIMENSIONS IN MILLIMETERS ( INCHES ) UNLESS OTHERWISE SPECIFIED.

VOLUME 7 - C.O.E.  
DESIGN & CONSTRUCTION  
STANDARDS

REVIEWED BY STANDARDS  
COMMITTEE: 2015-11-04

DRAFTED BY: R. LAWRIE

DESIGNED BY: M. MIX

SCALE: N. T. S.

DATE REVISED: 2016-03-09



INSTALLATION OF  
PRECAST CONCRETE BASE  
OVER SPLICE PITS

STANDARD NO.  
66 00 07 00 48 100

PAGE NO.  
1 / 2

20170602 16:05 r lawrie 1:25



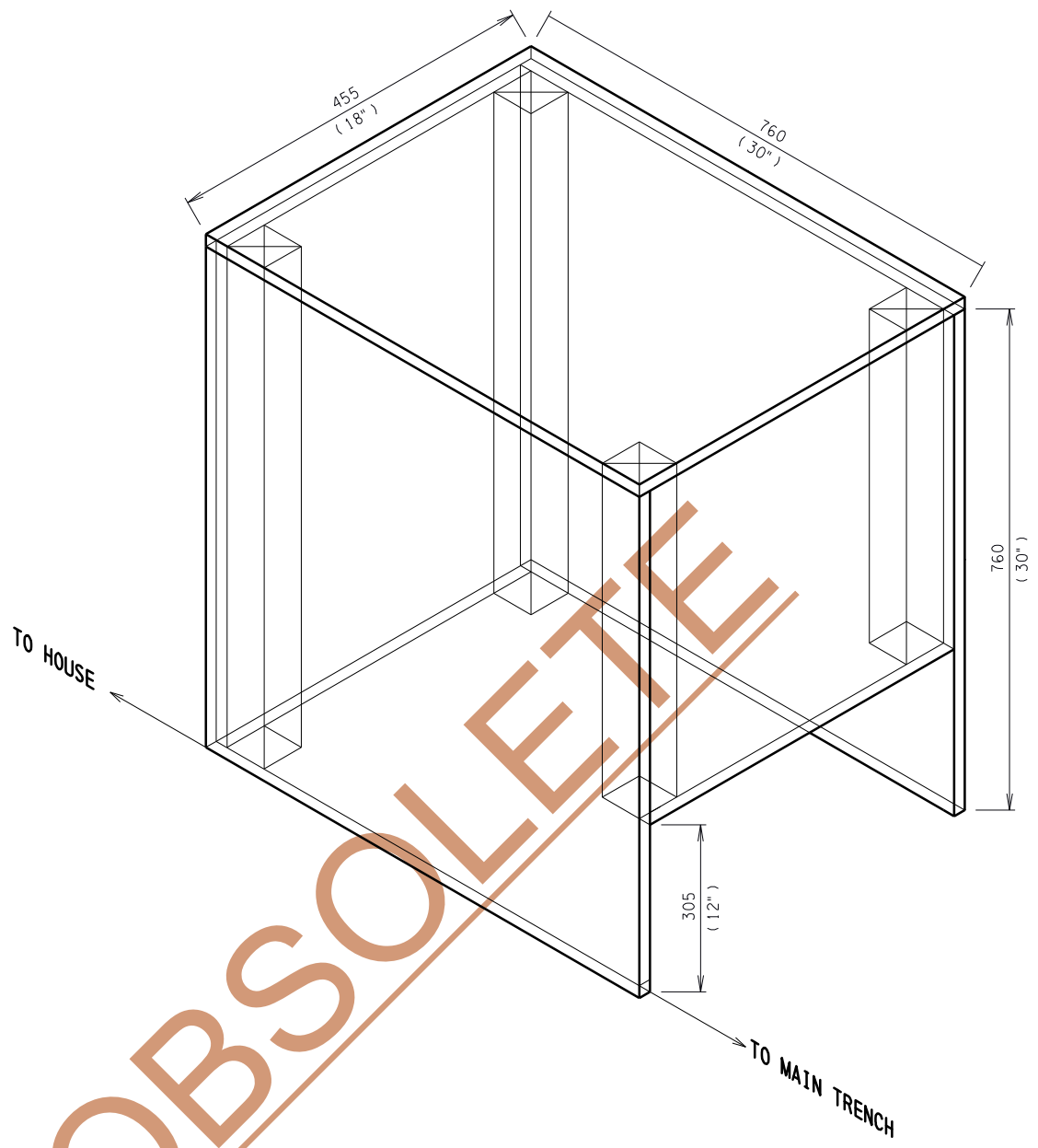

**NOTES:**

1. USE A MINIMUM 12.5 mm (1/2 inch) SHEET OF PLYWOOD OR ORIENTED STRAND BOARD.
2. STAPLES, NAILS OR SCREWS CANNOT BE EXPOSED INSIDE OF BOX.
3. USE 2" X 2" FOR FRAMING (NOT REQUIRED ON THE TOP PANEL)
4. THE FRAME AND PLYWOOD OR O.S.B. MUST BE CAPABLE OF SUPPORTING BACKFILL AND SAND AS WELL AS EQUIPMENT (THE TOP PANEL MUST OVERLAP THE OTHER 4 PANELS TO ADD STRENGTH FOR SUPPORTING BACKFILL).
5. THE BOTTOM OF BOX IS OPEN AS WELL AS A 305 x 455 mm OPENING IN THE FRONT OF THE BOX.
6. WHERE CABLE IS LARGER THAN 1/0, A SECOND BOX FOR COMMUNICATIONS IS REQUIRED.
7. A 2" x 4" MARKER PAINTED YELLOW MUST BE BURIED BEHIND THE BOX (450 mm ABOVE GRADE) TO IDENTIFY THE LOCATION OF THE BOX.

ALL DIMENSIONS IN MILLIMETERS ( INCHES) UNLESS OTHERWISE SPECIFIED.

20170602 16:30 r lawrie

<p><b>VOLUME 7 - C.O.E.</b>  <b>DESIGN &amp; CONSTRUCTION</b>  <b>STANDARDS</b></p>		<p><b>TYPICAL SERVICE BOX</b>  <b>POWER/CATV/TEL</b></p>
<p>REVIEWED BY STANDARDS COMMITTEE: YYYY-MM-DD</p> <p>DRAFTED BY: B. O'CALLAGHAN</p> <p>DESIGNED BY: B. O'CALLAGHAN</p> <p>SCALE: N. T. S.</p> <p>DATE REVISED: 2016-12-08</p>		<p>STANDARD NO.  <b>66 00 07 02 48 001</b></p> <p>PAGE NO.  1 / 4</p>



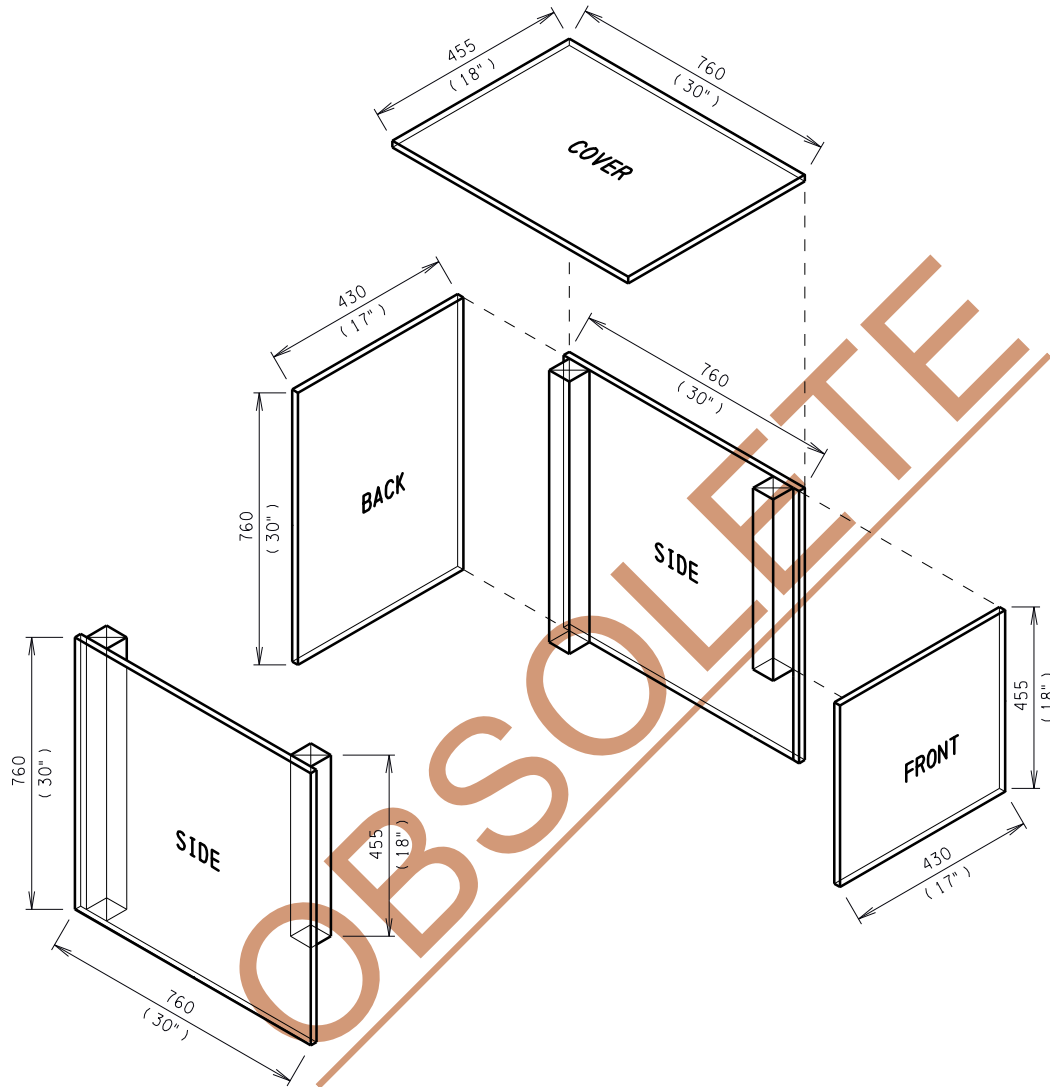

ALL DIMENSIONS IN MILLIMETERS (INCHES) UNLESS OTHERWISE SPECIFIED.

**VOLUME 7 - C.O.E.  
DESIGN & CONSTRUCTION  
STANDARDS**

REVIEWED BY STANDARDS  
COMMITTEE: YYYY-MM-DD  
DRAFTED BY: B. O'CALLAGHAN  
DESIGNED BY: B. O'CALLAGHAN  
SCALE: N. T. S.  
DATE REVISED: 2016-12-08



**TYPICAL SERVICE BOX  
POWER/CATV/TEL**

STANDARD NO.  
**66 00 07 02 48 001**

PAGE NO.  
2 / 4

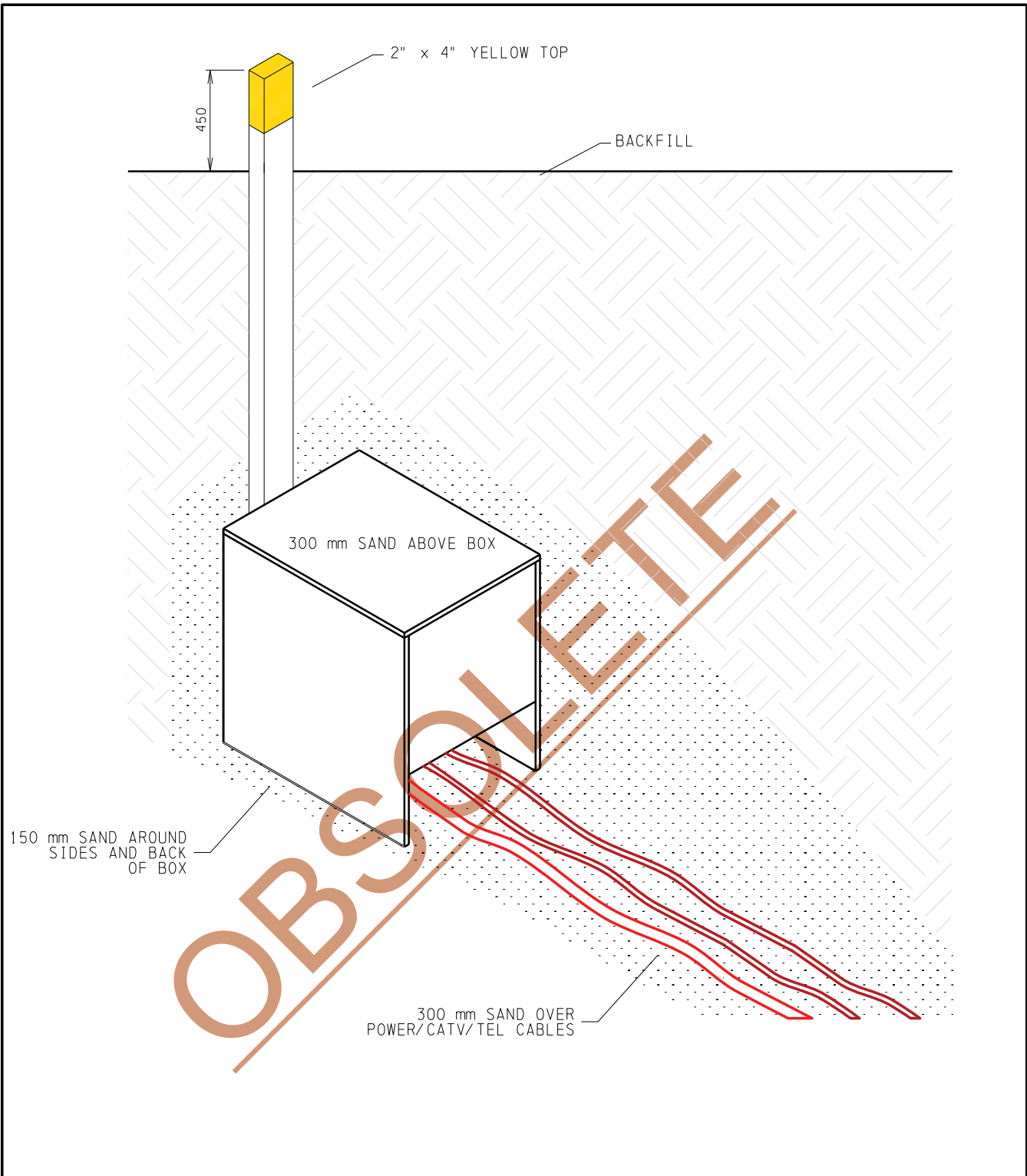

ALL DIMENSIONS IN MILLIMETERS (INCHES) UNLESS OTHERWISE SPECIFIED.

20170602 16:31 rlowrie

<p><b>VOLUME 7 - C.O.E.</b>  <b>DESIGN &amp; CONSTRUCTION</b>  <b>STANDARDS</b></p>		<p><b>TYPICAL SERVICE BOX</b>  <b>POWER/CATV/TEL</b></p>
<p>REVIEWED BY STANDARDS COMMITTEE: YYYY-MM-DD</p>		
<p>DRAFTED BY: B. O'CALLAGHAN</p>		
<p>DESIGNED BY: B. O'CALLAGHAN</p>		
<p>SCALE: N. T. S.</p>		
<p>DATE REVISED: 2016-12-08</p>	<p>STANDARD NO.  <b>66 00 07 02 48 001</b></p>	<p>PAGE NO.  3 / 4</p>

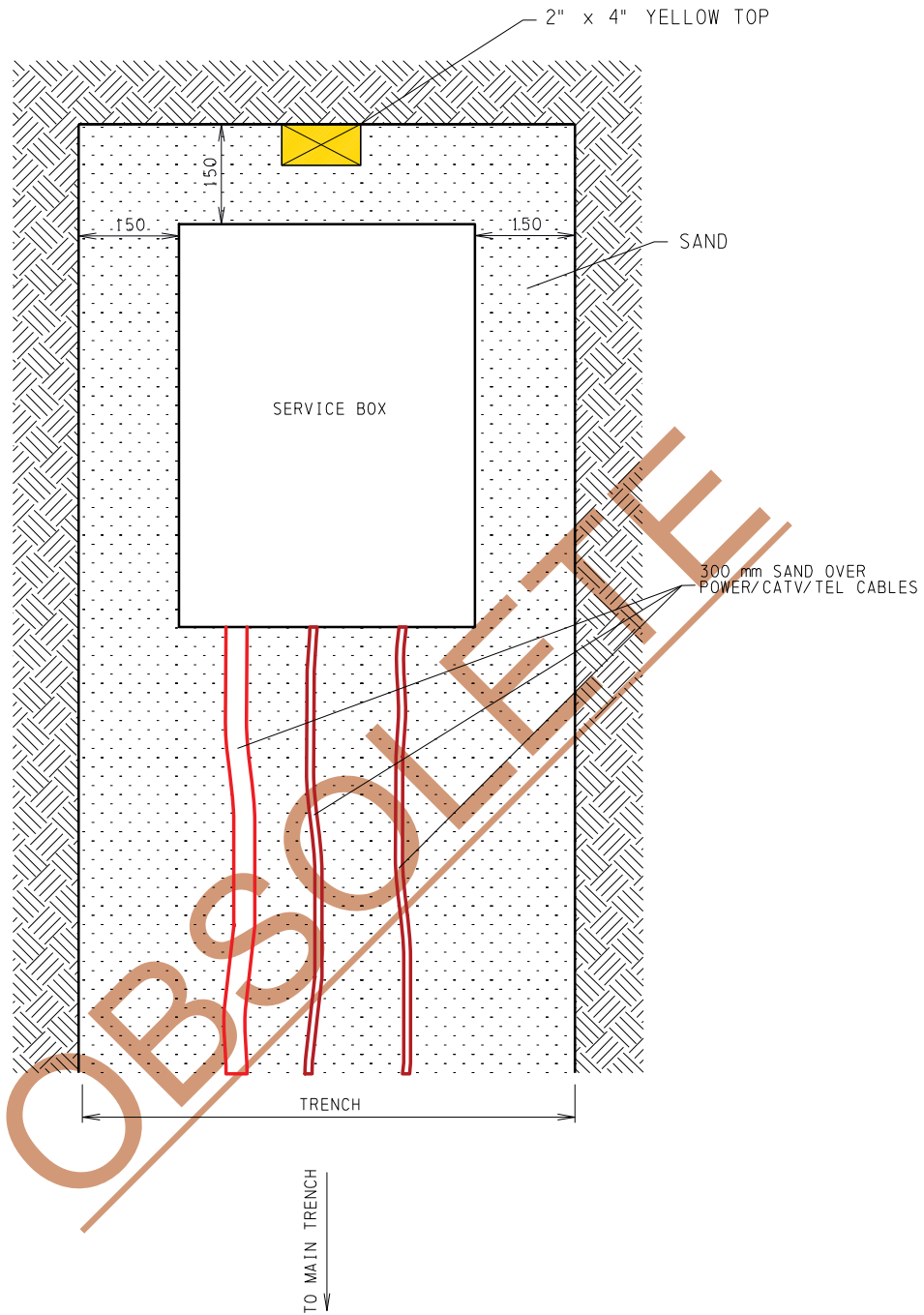

ALL DIMENSIONS IN MILLIMETERS (INCHES) UNLESS OTHERWISE SPECIFIED.

**VOLUME 7 - C.O.E.  
DESIGN & CONSTRUCTION  
STANDARDS**

REVIEWED BY STANDARDS  
COMMITTEE: YYYY-MM-DD  
DRAFTED BY: B. O'CALLAGHAN  
DESIGNED BY: B. O'CALLAGHAN  
SCALE: N. T. S.  
DATE REVISED: 2016-12-08



**TYPICAL SERVICE BOX  
POWER/CATV/TEL**

STANDARD NO.  
**66 00 07 02 48 001**

PAGE NO.  
4 / 4