

DEVELOPMENT GUIDE

for

**EPCOR Water New Mexico, Inc.
Edgewood District
Santa Fe and Torrance Counties
New Mexico**

Prepared by:



DENNIS ENGINEERING COMPANY

www.decnm.com

833-332-1753



This Page Intentionally Left Blank

Revision History:

December 27, 2019

1st Publication

October 7, 2022

2nd Publication



This Page Intentionally Left Blank



Table of Contents

| | |
|--|-----------|
| CHAPTER 1 | 1 |
| GENERAL INFORMATION..... | 1 |
| CONTACT LIST | 3 |
| EPCOR WATER DEVELOPER SERVICES – FEE SCHEDULE | 5 |
| UTILITY OWNERSHIP OF FACILITIES | 7 |
| GENERAL REQUIREMENTS FOR WATER EXTENSIONS..... | 9 |
| DEVELOPER SERVICES SUBMITTAL LIST..... | 11 |
| REQUIREMENTS FOR DEVELOPER..... | 13 |
| PUBLIC WATER SYSTEM PROJECTS..... | 15 |
| CHAPTER 2 | 17 |
| MASTER PLANS AND DESIGN CRITERIA FOR SUBDIVISIONS AND COMMERCIAL DEVELOPMENTS | 17 |
| MASTER PLANNING AND DISTRIBUTION MAIN REQUIREMENTS..... | 19 |
| DESIGN CRITERIA FOR WATER SYSTEMS | 21 |
| MASTER WATER PLAN OUTLINE | 27 |
| CHAPTER 3 | 31 |
| CONSTRUCTION PLAN REQUIREMENTS..... | 31 |
| ENGINEERING PLAN REQUIREMENTS FOR WATER LINE EXTENSIONS | 33 |
| GENERAL NOTES | 35 |
| WATER SYSTEM MATERIAL SPECIFICATIONS | 37 |
| PLAT DEDICATION VERBIAGE | 39 |
| “RECORD DRAWING” PLAN REVIEW REQUIREMENTS | 41 |
| WATER “RECORD DRAWING” CERTIFICATION..... | 43 |
| CHAPTER 4 | 45 |
| CONSTRUCTION INSPECTION..... | 45 |
| PROCEDURE FOR SCHEDULING WATERLINE CONSTRUCTION INSPECTIONS..... | 47 |
| CHAPTER 5 | 49 |
| BACKFLOW PREVENTION | 49 |
| PREMISES REQUIRING BACKFLOW PREVENTION | 51 |
| CHAPTER 6 | 53 |
| STANDARD DETAILS | 53 |



APPENDICES..... 57

APPENDIX A

APPLICATION REQUIREMENTS FOR APPROVAL TO CONSTRUCT WATER FACILITIES

APPENDIX B

NMED DRINKING WATER BUREAU APPLICATION FOR CONSTRUCTION OR
MODIFICATION OF A PUBLIC WATER SUPPLY SYSTEM

APPENDIX C

NMDOT FORM No. M-202

APPLICATION FOR PERMIT TO INSTALL UTILITY FACILITIES WITHIN PUBLIC RIGHT
OF WAY

APPENDIX D

NMDOT UTILITY PERMIT APPLICATION CHECKLIST

APPENDIX E

LINE EXTENSION AGREEMENT (LXA)

APPENDIX F

RELEASE AND WAIVER OF LIEN

MATERIALS AND/ OR LABOR



CHAPTER 1

GENERAL INFORMATION



This Page Intentionally Left Blank



CONTACT LIST

EPCOR Water New Mexico, Inc.

**Edgewood District
P. O. Box 370
38 Cactus Road
Edgewood, NM 87015
Phone: 505-281-3294
Fax: 505-281-0219**

| NAME | TITLE | DIRECT # | MOBILE # | EMAIL |
|-------------|--------------------|-----------------|-----------------|--|
| Tom Torres | Operations Manager | 505-281-3294 | 505-264-3431 | ttorres@epcor.com |
| | | | | |
| | | | | |
| | | | | |
| | | | | |
| | | | | |
| | | | | |
| | | | | |
| | | | | |



This Page Intentionally Left Blank



EPCOR WATER DEVELOPER SERVICES – FEE SCHEDULE

All fees are subject to change.

| | |
|--|-------------------------|
| Review Fee for Master Plan Reports for developments with 100 or less residential services | \$1,500 per report type |
|--|-------------------------|

- This fee is submitted to Utility along with the “Application for Water Main Extension” and with the Master Plan Report.
- The Types of Master Plan Reports include water.

| | |
|--|-------------------------|
| Review Fee for Master Plan Reports for developments with more than 100 residential services | \$2,500 per report type |
|--|-------------------------|

- This fee is submitted to Utility along with the “Application for Water Main Extension” and with the Master Plan Report.
- The Types of Master Plan Reports include water.

| | |
|--|-------------------------|
| Review Fee for Master Plan Reports for commercial development | \$2,500 per report type |
|--|-------------------------|

- This fee is submitted to Utility along with the “Application for Water Main Extension” and with the Master Plan Report.
- The Types of Master Plan Reports include water.

| | |
|------------------------|---------|
| Plan Review Fee | \$5,000 |
|------------------------|---------|

- Does not apply to projects that are “fire protection services only.”
- This fee is submitted to Utility along with the “Application for Water Main Extension” and with the first submittal of engineering plans and specifications to Utility for review.

| | |
|---|---------|
| Plan Review Fee – Fire Protection Only | \$2,500 |
|---|---------|

- This fee is submitted to Utility along with the “Application for Fire Lines” And with the first submittal of engineering plans and specifications to Utility for review.

| | |
|--|---|
| Construction Administration Fee | \$6,500 + 5% of the Engineer’s Estimated Total Cost of Construction |
|--|---|

- Does not apply to projects that are “fire protection services only.”
- This fee is due upon execution of the Line Extension Agreement.
- The developer’s engineer determines the estimated total cost of Construction of the line extension, which is added as an exhibit to The Main Extension Agreement.

| | |
|---------------------|--|
| Hook-Up Fees | As stated in NMPRC/.../Edgewood District As stated in NMPRC/ /Thunder Mountain District |
|---------------------|--|

| | |
|-------------------------|--|
| Water Meter Fees | As stated in NMPRC/.../Edgewood District As stated in NMPRC/.../Thunder Mountain District |
|-------------------------|--|



This Page Intentionally Left Blank

UTILITY OWNERSHIP OF FACILITIES

All water facilities on the Utility side of the service meter, including meter, shall be Utility owned. All fire hydrants and related facilities shall be Utility owned. Fire sprinkler taps, isolation valves, and that portion of fire sprinkler services in the street right-of-way or dedicated public utility easement shall be Utility owned. Utility will endeavor to install meters as close as possible to the property line, provided there is public access to the meter location.

The facilities described above shall become the sole property of the Utility when accepted, and full legal and equitable vested title thereto in utility, free and clear of any liens, without the requirement of any written document of transfer to utility or acceptance by utility.

All construction plans and final plats shall contain EPCOR plat dedication verbiage. See Chapter Three, *Construction Plan Requirements* for dedication verbiage.

Note: Utility means EPCOR Water New Mexico, Inc.

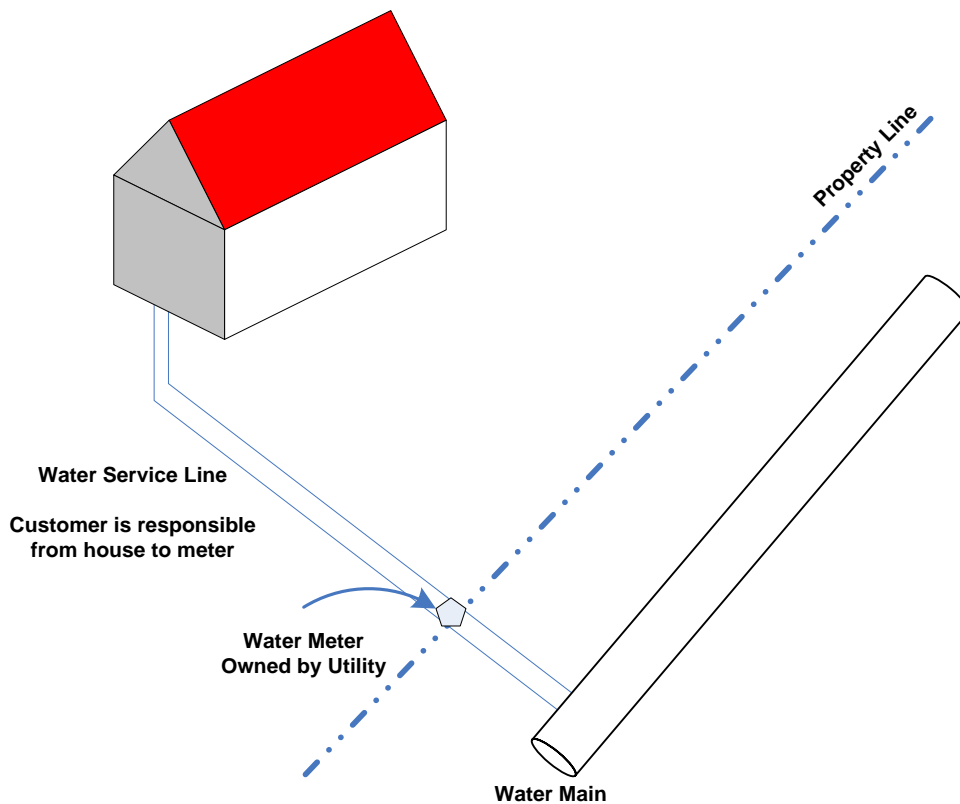



This Page Intentionally Left Blank

GENERAL REQUIREMENTS FOR WATER EXTENSIONS

1. Developer shall request water service in writing (see Appendix A - "Application Requirements for Approval to Construct Water Facilities"). Developer shall include the following with request:
 - a. Legal description of the property served.
 - b. Name and Address of project.
 - c. Name and Address of landowner.
 - d. Name and address of developer and the name and title of person authorized to sign agreements for developer. The developer must be registered with the New Mexico Public Regulation Commissions to do business in New Mexico.
 - e. General description of project (single-family residential, apartment, condominium, shopping center, etc.) with time schedule for development if known.
 - f. Include plat and site plan if they are available.
2. When an extension of the Utility's waterlines is required to serve a proposed development, Developer must execute a Line Extension Agreement ("LXA") with Utility before commencement of construction of the waterline extension. Please note that Utility will not, under any condition, approve an extension that would be unprofitable and thereby cause undue financial burden to existing customers.
3. Developer must provide a perpetual right of easement for all Utility owned water mains and related facilities placed on private property prior to beginning construction.
4. With regards to construction of the waterline extension, Developer may implement one of the following two options:
 - a. Developer may design and build the waterline extension in accordance with the terms of the LXA. The design must be reviewed and approved by the Utility prior to construction, and the construction must be inspected, tested, and approved by the Utility (all subject to Utility's plan review and inspection fees). Developer's engineer will be responsible to correct all design deficiencies, obtain all permit approvals, create record drawings, and satisfy all pertinent requirements in this guide (including items listed on pages 9 – 14) and in the LXA.
 - b. Developer may pay Utility to design and build the waterline extension in accordance with the New Mexico Public Regulation Commission Rules and Regulations. Utility will provide Developer an invoice that describes the cost estimate of the extension. Developer will provide a cash deposit for the cost of the materials and, upon receipt of the deposit, Utility will promptly order all materials. Upon receipt of the materials, and receipt of all reasonable information concerning the project from Developer, Utility will advise Developer of the construction schedule. Utility will commence construction of the extension upon receipt of the balance of the deposit from Developer.
 - i. In the event the Utility's actual cost of construction is less than the amount advanced or contributed by Developer, the Utility will refund the over-payment to the Developer within 30 days after completion of construction or Utility's receipt of final construction invoices.
 - ii. In the event the Utility's actual cost of construction is greater than the amount advanced or contributed by Developer, the Utility will invoice the Developer for the balance of the Developer's portion of the cost of the project. The Developer shall, within thirty (30) days after receipt of the invoice, submit payment to the Utility for the remaining balance.



5. The amount of funding provided by the Developer for the on-site portion of the extension, either through the construction of the on-site facilities (per 4.a above) or through the advance of cash (per 4.b above), will be considered a refundable "Advance in Aid of Construction." The off-site portion of the extension will be considered a non-refundable "Contribution in Aid of Construction." All refundable advances will be refunded in accordance with the terms of the LXA. Any balance of such advances remaining at the end of the applicable refund period shall become non-refundable. No interest shall be paid on any amount advanced by Developer.
6. All waterlines shall be installed in rights-of-way or easements. Developer shall furnish such rights-of-way or perpetual right of easement, at no cost to Utility, prior to commencement of construction of the waterlines.



DEVELOPER SERVICES SUBMITTAL LIST

These items are to be provided by developer. These items are to be provided before, during or after construction as indicated by numeric portion of code.

| <u>Item</u> | <u>Code</u> | <u>Item Description</u> |
|-------------|-------------|--|
| 1. | A, 1* | 24"x36" Waterline plan, approved plat map and CAD files |
| 2. | A, 1 | Water Material Specifications |
| 3. | B, 1 | Property Legal Descriptions in 8½"x11" format for incorporation into the Easement document (when needed). All legal descriptions shall have a corresponding exhibit. |
| 4. | B, 1 | Project Drawing showing property, easements, water facilities and ROW's in 11"x17" format suitable for incorporation into the Line Extension Agreement. |
| 5. | A, 1 | Engineer's Estimate of Probable Cost |
| 6. | D, 1 | Line Extension Agreement (LXA) |
| 7. | A, 1 | Written Approval to Construct issued by the New Mexico Environmental Department Drinking Water Bureau (NMED-DWB) or, if approval is not required, a copy of the first page of the "Application for Construction or Modification of a Public Water Supply System" as submitted to NMED-DWB. |
| 8. | A, 1 | Engineering Design Summary, which must include engineering information as required to set out the basis of the design of the proposed project. |
| 9. | B, 1 | Master Water Plans for Subdivision and Commercial Developments |
| 10. | A, 2 | Address/Lot Map/CAD File |
| 11. | C, 1 | Water Material Submittals and Certificates |
| 12. | C, 2 | Trench Compaction Test Results |
| 13. | A, 2 | Final Recorded Property Plat and/or Final Recorded Easement |
| 14. | C, 2 | Backflow Prevention Assembly and Certification Data submitted to Utility Water Quality Specialist (Backflow Prevention) for Approval |
| 15. | A, 3 | Certified Record Drawings on 24" x 36" (2 copies), and electronic media (PDF format) |
| 16. | D, 3 | Complete Project Invoice/Cost Data |
| 17. | C, 3 | Lien Waivers |

Codes:

A - Typically provided by Engineer
B - Typically provided by Developer
C - Typically provided by Contractor
D - Provided by Utility

1 - Required prior to Start of Construction
2 - Required prior to Operational Acceptance
3 - Required for Final Acceptance

* All items listed with code of 1 shall be submitted to Utility for approval prior to construction.



This Page Intentionally Left Blank

REQUIREMENTS FOR DEVELOPER

Designed and Built Water Main Extensions

1. Either Developer's engineer shall prepare and submit Water Plans in accordance with the Utility's "Engineering Plan Requirements" (see Chapter 3) or Utility will prepare, or will cause to be prepared, Engineering Plans as necessary to provide water to the new development.
2. Utility engineers will be available to discuss plan development and design concepts. The developer is encouraged to contact the Utility prior to plan development for special instructions that may apply to a particular expansion.
3. Easements, legal descriptions and exhibits shall be required for all Utility- owned facilities not within dedicated right-of-ways. Easements shall have a minimum width of 15 feet and shall be centered about the centerline of the Utility-owned facilities. The easement legal descriptions and exhibits shall be submitted on 8½" x 11" sheets and signed and sealed by a Land Surveyor licensed in the State of New Mexico.
4. If Developer has its engineer prepare the Engineering Plans, then Developer must supply the Utility with a copy of the approval for construction as issued by the New Mexico Environment Department Drinking Water Bureau (NMED-DWB) prior to commencing construction. If the project is exempt from the approval process, as defined in Section 20.7.10.200.B. of the New Mexico Drinking Water Regulations, then there is no requirement to notify or seek approval from the NMED-DWB.
5. If Developer has its contractor install waterline extensions, then:
 - a. Developer is responsible for notifying the municipality and/or county if construction will occur within the municipality and/or county's rights-of-way. The required forms for notification can be obtained from the municipality or county and a copy of the completed form shall be submitted to Utility as well as to municipality and/or county.
 - b. Developer's contractor shall install materials approved in writing by the Utility.
 - c. Developer shall construct system in accordance with the New Mexico Standard Specifications for Public Works Construction, 2006 Edition, as presently modified and updated.
 - d. Utility will conduct periodic inspections of the installation. Utility does not provide full-time on-site inspection. Responsibility for proper installation rests with the Developer. Such inspection, as Utility personnel may perform, in no way relieves the Developer of this responsibility.
 - e. Developer shall not make any changes from approved plans and specifications without prior approval of the Utility. Change orders authorizing changes in the approved plans and specifications must be co-signed by the engineer of record and Utility prior to construction of the change.
 - f. Utility will give final acceptance upon completion of all construction, including final adjustments of all valve boxes, meter boxes, etc. and submittal of any other required documentation.

- g. The date of final acceptance shall be the date of the letter from the Utility to Developer unless indicated otherwise by the conditions of the Line Extension Agreement. Developer shall be responsible for the repair of the facilities installed for one year from the date of final acceptance.
- h. In order to establish actual cost of construction, developer shall provide copies of all invoices for material and labor for that portion of the work to be owned by Utility. The invoices must be itemized and should include engineering, construction supervision, actual installation costs, and any other costs directly associated with the project.
- i. Developer shall provide unconditional lien releases from all contractors, subcontractors, and material suppliers for all water construction. A copy of the release form is in Appendices of this development guide.
- j. Developer shall provide a "Record Drawing" plan of facilities installed. The "Record Drawing" plans shall include the locations of all vertical and horizontal pipe bends, valves, etc., by station/offset and northing and easting state plane coordinates. The plan must be provided on 24" x 36" paper (2 copies) and electronic media (PDF format) and certified for correctness by a Professional Civil Engineer licensed in the State of New Mexico. Reference the "Record Drawing" section, Chapter Three Construction Plan Requirements, for detailed "Record Drawing" plan requirements.
- k. No refunds for "Advances in Aid of Construction" will be made prior to receipt of invoices, lien waivers and approved "Record Drawing" plans.

PUBLIC WATER SYSTEM PROJECTS

All public water systems (PWS) are required under the NEW MEXICO DRINKING WATER REGULATIONS (20.7.10.200 and 20.7.10.201 NMAC) to obtain written approval from the New Mexico Environment Department-Drinking Water Bureau (NMED-DWB) before it undertakes a public water system project. A public water system project is defined as “the construction of a new public water system, modification to an existing public water system, or conversion of a non-public water system to a public water system.”

Before construction of a public water system project, an APPLICATION FOR CONSTRUCTION OR MODIFICATION OF PUBLIC WATER SYSTEM must be submitted to the engineering staff at NMED-DWB. The project may not be put into operation until written approval has been received from NMED-DWB.

The following activities are considered on-going operations and routine maintenance procedures. These activities are not considered public water system projects. There is no requirement to notify or seek approval of the NMED-DWB for these activities:

1. pipeline leak repair;
2. replacement of existing deteriorated pipeline, or addition of distribution pipeline, if such replacements or additions, or both, total less than 1,000 feet in any 60 calendar day period;
3. entry into a drinking water storage facility for the purposes of cleaning and maintenance;
4. the replacement of chemical feed pumps and associated appurtenances;
5. the replacement of electrical or mechanical equipment in an existing public water supply system; and
6. the replacement of equipment or pipeline appurtenances with the same type, size and rated capacity (fire hydrants, valves, pressure regulators, meters, service laterals, chemical feeders and booster pumps including deep well pumps).

Any person proposing to undertake the following public water system projects must give NMED-DWB written notice by submitting an application; but may undertake the project without written approval from NMED-DWB. NMED-DWB will notify the applicant within 15 days if there is a need to submit a complete application.

1. a modification that involves only the replacement or construction of more than 1,000 feet of distribution lines, or of appurtenances, pump stations, or pressure regulating facilities for which the public water system employs, either by contract or direct employment, a registered professional engineer who is responsible for the project; or
2. installation of a hypochlorination system, including an on-site hypochlorination generation system, in a public water system under the following conditions:
 - a. water is supplied by ground water that is not under the direct influence of surface water;
 - b. the owner or operator of the system employs, by contract or direct employment, a water operator certified in New Mexico at the level required in the Utility Operator Certification Regulations, 20.7.4 NMAC; and
 - c. the certified operator is responsible for the project and certifies the inactivation ratio achieved by the hypochlorination system; the water system operator shall calculate the inactivation ratio and document the calculation on a form provided by the department.

NOTE: Even if the public water system project does not require approval the first page of the “Application for Construction or Modification of a Public Water System” must be completed and submitted to NMED-DWB. A copy of this submittal must be sent to the Utility.



This Page Intentionally Left Blank



CHAPTER 2

MASTER PLANS AND DESIGN CRITERIA FOR SUBDIVISIONS AND COMMERCIAL DEVELOPMENTS



This Page Intentionally Left Blank

MASTER PLANNING AND DISTRIBUTION MAIN REQUIREMENTS

Distribution systems must be designed in accordance with Utility's design requirements, applicable state and local requirements, sound engineering practices, and other applicable codes and recognized standards. Distribution systems must be designed with sufficient "looping" and other redundancies as may be necessary to minimize outages to customers in the event of main breaks, routine maintenance, and repairs. Distribution systems should be sized to accommodate sufficient fire flows as may be required. The design and sizing of the distribution systems should include a main break analysis to ensure the provision of adequate fire flows and service to our customers.

As a condition of service, and in addition to the distribution system design standards, Utility requires that distribution systems include a secondary 8-inch diameter distribution main that is in addition to the normally required "backbone" or larger diameter distribution mains. The selected alignment of the secondary distribution main would ideally traverse the center of the development or phase of development, originating and terminating at larger "backbone" mains. This requirement is not to be construed as a request for oversizing, rather as a sound engineering design condition.

Plan submittals from the developer's engineer will be reviewed by Utility for the inclusion and acceptability of the secondary distribution main and its alignment. Developers are strongly encouraged to coordinate this important design element with Utility during the preliminary master planning and design process.

An approved water distribution analysis is required to accompany all waterline engineering plans. The analysis shall identify proper distribution sizing based on the required flow parameters, as well as the criteria listed above.

When Master Water Plans are required, the Master Plans will be reviewed by Utility to ensure new developments are coordinated and consistent with the long term Master Water Plans of the relevant service area. Developers are required to submit two copies of the Master Water Plan and the appropriate electronic files of the hydraulic analysis. Initial Master Plan reviews may take up to eight weeks for initial review depending on the complexity of the project. This does not include any time needed for revisions and subsequent reviews. Failure to provide two copies of the Master Water Plan as well as electronic files for the hydraulic model may result in a delay of Utility's review that may then take more than eight weeks.

A hydraulic analysis using the current version of WaterCAD (or equivalent with prior approval of Utility), must be performed for the proposed water distribution system and submitted as part of the Master Plan. The Master Plan shall be prepared in accordance with Utility's master plan outline. A color exhibit showing water line locations, sizes, parcel boundaries, junctions, contour elevations, pressure zone boundaries, etc. shall be submitted as part of the Master Plan. In addition to the hard copy documents required here, the submittal must also include a copy of the full hydraulic model and any tabular files used for the hydraulic analysis in electronic format on CD or USB Flash Drive. The Master Plan shall be signed and sealed by a Registered Professional Civil Engineer in the State of New Mexico and submitted to Utility for review and approval.

Any and all criteria not listed herein shall be in accordance with, but not limited to, regulations and requirements of local jurisdictions and governmental agencies. All developments shall be compliant with AWWA standards. Fire flow requirements shall be determined by the jurisdictional Fire Marshal and the requirements shall be stated in a letter from the Fire Marshal, which must be included as an appendix with the Master Plan .



This Page Intentionally Left Blank

DESIGN CRITERIA FOR WATER SYSTEMS

1. Demands¹

| Land Use | Unit | Average Day Demand (gal/day/unit) | Max Day Peaking Factor | Peak Hour Peaking Factor |
|--|-------------|-----------------------------------|------------------------|--------------------------|
| Active Adult | Dwelling | 304 | 1.8 | 3.0 |
| Single Family | Dwelling | 360 | 1.8 | 3.0 |
| Multi Family | Dwelling | 240 | 1.8 | 3.0 |
| Commercial ² | Acre | 1,700 | 1.8 | 3.0 |
| Warehouse/Big Box Retail | 1,000 sq ft | 30 | 1.8 | 3.0 |
| Developed Open Space, including Parks ^{2,3} | Acre | 1,800 | NA | NA |
| Schools ² | Acre | 1,700 | NA | NA |
| Hotel (no restaurant) | Room | 140 | 1.8 | 3.0 |
| Hotel (with restaurant) | Room | 200 | 1.8 | 3.0 |

¹Please contact Utility's Planning Division for Resource Data on other demand types.

²Acreage is based on gross number of acres

³Developed Open Space includes general landscaped areas where irrigation will be required, such as road medians to be maintained by HOA's.

2. Pressures

Minimum Pressures: 55 psi static and 40 psi @ peak hour, 20 psi at max day + fire flow

Maximum Pressures In accordance with the Uniform Plumbing Code, any structure subjected to pressures greater than 80 psi shall have an individual pressure reducing valve on the customer side of the meter. Areas where many customers experience pressures higher than 80 psi may require a PRV station or modification to the distribution system to be approved by the Utility.

3. Velocity & Headloss 10 fps maximum velocity for distribution system
2 fps minimum and 6 fps maximum velocity for well transmission lines
10 ft. headloss per 1,000 linear feet of pipe

4. Hazen-Williams Coefficient 130 (for new pipe), the Darcy-Weisbach equation must be used for booster station design.

Where development models include existing pipes, appropriate coefficients will need to be selected. Where an existing calibrated model exists, the coefficients in the existing model must be used. If there is no existing calibrated model, the developer's engineer will need to consult with Utility's planning division.

Design Criteria for Water Systems (Continued)

5. Fire Flows¹

Fire flows must be in accordance with the jurisdictional Fire Marshall requirements. Provide a written statement from the jurisdictional Fire Marshall that states the required fire flows and duration by class of customer. In the absence of a jurisdictional Fire Marshall, fire flow requirements must be in accordance with the latest version of the International Fire Code.

6. Minimum Size Line Requirements

Minimum size for transmission lines shall be 12-inches, minimum size for distribution lines shall be 8-inches unless otherwise approved by Utility.

7. Storage Requirements

| | |
|-------------------|--|
| Equalization | 30% of max day, plus |
| Emergency reserve | the greater of 10% of max day OR the storage volume required based on the fire flow requirements stated above. |

8. Booster Pump Stations

| | |
|---------------|--|
| Firm Capacity | Shall meet or exceed the greater of peak hour flow or max day + fire flow with the largest pump out of service for the pressure zone(s) that the booster station serves. Shared redundancy between pressure zones may be acceptable via a PRV (with prior approval of the Utility) provided adequate redundancy exists in the higher zone. |
|---------------|--|

9. Water Valves

Number of Valves = number of radiating mains at intersection minus one; the unvalved branch is the line that supplies the intersection.

Valves should be located at not more than 500- foot intervals in commercial districts and at not more than one block or 800- foot intervals in other districts. Where systems serve widely scattered customers and where future development is not expected, valve spacing should not exceed one mile.

Valves in well transmission mains shall be kept to a minimum.

10. Wells

Where developments are supplied solely by groundwater wells, the following criteria must be met:

Firm Capacity: Any wellfield supplying a booster station must meet the maximum day demand for the entire station with the greatest producing well out of service. Single source wellfields are not allowed. Proposed wells supplying directly into the distribution system are discouraged and will be reviewed on a case-by-case basis.

Permitted Capacity: The total *permitted* capacity of a wellfield shall be adequate to meet the anticipated total annual demand for the development.

Well transmission lines shall have a 12-inch minimum diameter. Where a transmission line will have multiple wells connected to it, the pipe shall be sized such that **all** wells connected to that line can run simultaneously at their full capacity while meeting the velocity and headloss constraints defined in this guide. If this cannot be achieved, contact Utility for guidance.

¹ Subject to jurisdictional Fire Marshall
Developments will be reviewed on a case by case basis



Design Criteria for Water Systems (Continued)

11. Fire Hydrants

Hydrants should be provided at each street intersection and at intermediate points between intersections as recommended by the State Insurance Services Office and local firefighting authorities. The local firefighting authority should be contacted to determine the proper fire hydrant type, size, number of connections, connection sizes, and threading on fire hydrant nozzles. The hydrant lead should be a minimum of six inches in diameter, unless otherwise required by the local firefighting authority. Auxiliary valves should be installed in all hydrant leads of the size and type required by the local firefighting authority. Where hydrant drains are not plugged, a gravel pocket or dry well should be provided. Hydrant drains should not be connected to or located within 10 feet of sanitary sewers or storm drains.

12. Combination Air/ Vacuum Valves

Combination Air/ Vacuum valves (CAV's) shall be located at all high points and at vertical realignments of the water line. CAV's should not be used in situations where flooding of the manhole or chamber may occur.

13. Pressure Reducing Valves

Pressure reducing valves shall be located on "trunk" transmission/ distribution mains to maintain design pressure ranges in accordance with established or proposed water master plans. These locations must be coordinated with, and approved by, Utility. PRV sizing shall be based on anticipated minimum/ maximum flow ranges.

14. Wash Crossings

All waterlines crossing washes or channels shall be MEG-A-LUG restrained joint ductile iron pipe (Class 350). The depth requirement for placing waterlines under washes or channels shall be the deeper of the following two cases:

- a. Minimum cover over the pipe shall be greater than or equal to two (2) feet below the scour depth (based on Scour Analysis). Scour analysis shall be evaluated with HEC-RAS v4.1.0 using guidelines outlined in the April 2012 Hydraulic Engineering Circular No. 18 (HEC-18).
- b. The minimum cover over the pipe may be based on the 100-year flow rate of the wash or channel as shown in the table below. Note that the "additional depth" in the table refers to the depth of pipe that must be added to the normal cover requirements that are provided in Detail No. 350-1.

| 100-Year Flow Rate | Additional Depth |
|----------------------|--|
| 1 to 49 cfs | 1 foot |
| 50 to 99 cfs | 2 feet |
| 100 to 499 cfs | 3 feet |
| Greater than 499 cfs | Scour Depth (based on Scour Analysis), minimum of 3 feet. |



Design Criteria for Water Systems (Continued)

Water Service line size

In accordance with the “Recommended Standards for Water Facilities” by the New Mexico Environmental Department Construction Bureau, residential service lines should have a minimum inside diameter of 3/4 inch. The service line shall be installed in accordance with Utility’s STD. DET. 342-2 and 342-3. Where the water meter size is greater than one inch, the service line must be the same size as the meter.

Residential Potable Water Meter Criteria (minimum)

All residential meters shall be at least as large as follows, and shall also be sized in compliance with the current National Plumbing Code (UPC) and any applicable municipal or other government requirements. Meters sized per the UPC shall be based on the maximum expected fixture units. Floor plans showing fixtures and fixture count meter sizing calculations shall be submitted to Utility for review and approval prior to approval of construction plans.

Water meter sizing-Single Family Homes

5/8" x 3/4" meter for all residential lots.

Larger meters will be considered on a case by case basis.

Water meter sizing- Commercial

Meter(s) will be sized per design and shall be capable of providing the required demand including fire flow. This may be accomplished with a series of meters.

For residences or commercial buildings that include fire sprinklers or landscape irrigation, the meter size shall be the greater of the following:

- 1) Meter size as determined by the current UPC, or
- 2) From each fire sprinkler zone within the building, the highest of these fire flows must be in accordance with the table below (i.e., if the calculated fire sprinkler flow is 31 gpm, then a 1-inch meter will be required), or
- 3) The landscape irrigation flow must be in accordance with the table below:

| Minimum Required Meter Size (inches) | Maximum Allowed Fire Flow or Irrigation Flow (gal/min) |
|---|---|
| 5/8 | 20 |
| 3/4 | 30 |
| 1 | 50 |
| 1-1/2 | 100 |
| 2 | 160 |
| 3 and larger | Determined on a case-by-case basis |

The maximum flows provided in the table above should only be imposed on the meter for short, intermittent periods. Meters should not be operated on a continuous 24-hour service at flows greater than one-half of the maximum flows provided in the table above.

Design Criteria for Water Systems (Continued)

Meter location

Meters shall be doubled up on lot lines where possible, shall not be installed at road intersection corners, and shall not be adjacent to fire hydrants. Each Service line requires a separate tap to the water main. See Detail 342-3. Proposed connections of two or more meters in a manifold configuration will be reviewed by Utility on a case-by-case basis. Existing service lines that will not be used by a development shall be abandoned and plugged at the water main.

Curvilinear Alignments

Design constraints are provided below:

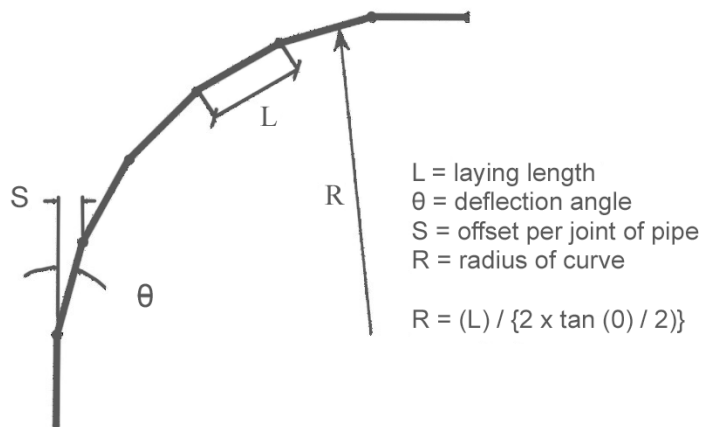

C900, DR18, PVC Pipe

| Pipe Diameter | Laying Length | Max Deflection Angle | Offset per joint of pipe | Min. Curve |
|---------------|---------------|----------------------|--------------------------|------------|
| 6" – 12" | 20' | 2.0° | 8.4" | 573' |

C905, DR18, PVC Pipe

In accordance with AWWA C605-94, section 5.6, the bending of the PVC Pipe barrels larger than 12-inch (300-mm) nominal diameter is not recommended due to the forces required. The curved alignment of PVC pipelines larger than 12-inch (300-mm) in diameter shall be determined by one-half the pipe manufacturers published axial-joint-deflection limits. Manufacturer's technical data sheets shall be submitted to Utility for review and approval.

Ductile Iron Pipe, AWWA C150/151/153

| Pipe Diameter | Laying Length | Max Deflection Angle | Offset per joint of pipe | Min. Curve |
|---------------|---------------|----------------------|--------------------------|------------|
| 8"-12" | 18' | 2.5° | 9.4" | 413' |
| 14"-16" | 18' | 2.0° | 7.5" | 516' |
| 18"-24" | 18' | 1.5° | 5.7" | 688' |
| 24" | 18' | 1.0° | 3.8" | 1032' |
| 8"-12" | 20' | 2.5° | 10.4" | 459' |
| 14"-16" | 20' | 2.0° | 8.4" | 573' |
| 18"-20" | 20' | 1.5° | 6.2" | 764' |
| 24" | 20' | 1.0° | 4.1" | 1146' |

Design Criteria for Water Systems (Continued)

DESIGN REQUIREMENTS FOR FIRE LINES

1. Fire line connections to Utility's mains shall be used for fire protection systems only. Metered services cannot be connected to fire lines.
2. The minimum size fire line connection shall be 4 inches.
3. For fire lines, backflow prevention devices are required within 75 feet of the main. If the building riser is within 75 feet from the main, then a vertically mounted backflow prevention device may be located on the building riser. If the building riser is further than 75 feet from the main, then a backflow prevention device shall be installed as close as practicable to the service connection (property line).
4. Backflow prevention devices are not required for private hydrant connections that are not looped and that do not have fire sprinkler connections.
5. Backflow prevention devices shall have been issued a certificate of approval by the University of Southern California Foundation for Cross-Connection Control and Hydraulic Research. The certificate of approval shall be forwarded to Utility's Backflow Prevention Specialist prior to Utility's Final Acceptance of the fire lines.
6. Backflow prevention devices shall not be located in rights-of-way, sidewalks, driveways, visibility triangles, or other locations where accidental damage or visibility obstruction would likely occur.
7. Backflow prevention devices shall be fully accessible for testing, repairs, and replacement. There shall be an unobstructed radius of not less than three feet from the outer perimeter of each backflow prevention device.
8. Per the Uniform Plumbing Code (610.2), in the absence of specific pressure drop information, the diameter of the inlet or outlet of any backflow prevention device or its connecting piping shall not be less than the diameter of such water distribution piping to the fixtures served by the device. If available, pressure drop information shall be provided with the submitted plans.
9. Per the Uniform Plumbing Code (603.3.11), looped on-site fire line systems shall have backflow preventers at each point of connection to the public water system.
10. A control valve is required at ALL fire line connections to public water mains. The control valve shall not be located in sidewalks, driveways, curbs or gutters.
11. Thrust blocks are not allowed in rights-of-way.

MASTER WATER PLAN OUTLINE

The following outline shall be used for the preparation of master plan reports:

1. Cover Sheet
 - a. Title (Development Name), Date, Revision Date(s)
 - b. Developer and engineer's contact information
 - c. Sealed by a Professional Engineer licensed in the State of NM
2. Table of Contents
3. Executive Summary
 - a. 1 or 2 pages with emphasis on proposed facilities to serve the development
4. Introduction
 - a. Plan Objective—state purpose of the report
 - b. Site Location w/ vicinity map
 - c. Proposed Development
5. Design Criteria
 - a. Demands, Pressures, Storage, Booster Pumps, Wells, Distribution System (pipe sizing)
 - i. Utility Development Guide Criteria
 - ii. NMED, other governmental agency criteria as applicable
 - iii. Generally accepted engineering standards (requires Utility approval)
6. Demands
 - a. Single family, multi family, commercial, school, open space, parks, etc.
 - b. Quarterly projections of demands from beginning of construction (construction water) to buildout
 - c. Summary of demands table. Discuss which demand scenario governs design (Peak Hour or Maximum Day plus Fire flow)
 - d. Tabular calculations (spreadsheet) of all demands
7. Existing Facilities/Conditions
 - a. Reference previous master water plans as applicable
8. Proposed Facilities
 - a. Required storage, proposed location, or expansion of existing if applicable
 - b. Required booster pump capacity
 - c. Required well capacity, number of wells if applicable
 - d. Distribution system piping, onsite as well as any offsite infrastructure needed
 - e. PRV's if applicable
 - f. Phasing if applicable

Master Water Plan Outline (Continued)

9. Water Model

- a. Describe model used
- b. Assumptions
 - i. Pump curves obtained from Utility information or fire flow tests
 - ii. Criteria used in the model

10. Results/ Discussion – proposed facilities are adequate to serve development based on hydraulics

11. Summary/Conclusions

- a. Discuss how the objective of report has been met, i.e. proposed facilities will serve the proposed development in accordance with established criteria.
- b. List major facilities required and phasing as applicable

12. Appendices

- a. Water Modeling Results Organized by:
 - i. Average Day
 - ii. Maximum Day
 - iii. Peak Hour
 - iv. Maximum Day plus Fire Flow
- b. The following information is to be included for the above scenarios:
 - i. Junction/Node report showing node label, elevation, demand in gpm, hydraulic grade line in feet, pressure in psi, and assigned pressure zone for that node (zone assignment to node shall be in accordance with the existing operation of the service area and in accordance with Utility naming conventions). Also, for phased developments, reports and exhibits should identify those nodes that are active and that are inactive for various model runs
 - ii. Pipe report showing pipe label, start/ stop node, length, diameter, Hazen-Williams “C” value, flow, velocity, headloss, headloss gradient, and intended year of installation
 - iii. Pump report showing pump label, elevation, discharge, discharge pump grade, and pump head. An attachment to the pump reports should also be included to show assumed pump patterns and efficiency curves for any pumps modeled in the hydraulic analysis
 - iv. Valve report showing valve label, elevation, diameter, valve status, discharge, and from/ to hydraulic grade line
 - v. Tank report showing tank label, base elevation, maximum elevation, volume, hydraulic grade line, and outflow
 - vi. Reservoir report showing reservoir label, elevation, hydraulic grade line, and outflow
 - vii. A separate fire flow report for the maximum day plus fire flow scenario shall be submitted. The fire flow report is to show the following information for all nodes: node label, satisfies fire flow constraint, needed fire flow, available fire flow, total flow available, residual pressure, minimum system pressure, and minimum system pressure node.

Master Water Plan Outline (Continued)

- viii. An extended period simulation (EPS) model showing storage tank levels varying with time may be required to verify adequate fire flow storage for complex system designs, to verify adequate fire flow storage and also to verify that wells have sufficient capacity for tank replenishment during maximum day demands. Where an EPS model is used, an explanation will be required for the basis of diurnal demand patterns, and the basis of demand allocation. A clear explanation will also be required for the different model scenarios. Finally, detail will be required on how the source of water has been modeled. A summary of the techniques used to generate the hydraulic model and engineering analysis should be clearly described.
- c. An 11" x 17" (24" x 36" for large development as applicable) color exhibit for peak hours Average day and maximum day exhibits may be required. Exhibits to include:
 - i. Pipes and nodes labeled
 - ii. Pressures at nodes
 - iii. Major roadways labeled
 - iv. Pipe size shown by color
 - v. Major contour lines shown
 - vi. Pressure zone boundaries
- d. Cost Estimate

*Figures, exhibits, tables, spreadsheet tabulations, etc. to be placed in the body of the report. (24" x 36" sheets in pocket included at the end of the report).



This Page Intentionally Left Blank



CHAPTER 3

CONSTRUCTION PLAN REQUIREMENTS



This Page Intentionally Left Blank

ENGINEERING PLAN REQUIREMENTS FOR WATER LINE EXTENSIONS

1. The engineering plans shall be clearly labeled “Water Plan”.
2. The plans shall be on 24” x 36” sheets.
3. The plans shall be signed and sealed by a Professional Civil Engineer licensed in the State of New Mexico.
4. The plans shall meet the requirements of the most current version of the New Mexico Environmental Department’s “Recommended Standards for Water Facilities”.
5. Appropriate design calculations and other supporting data shall be submitted with the plans.
6. The Utility’s “Material Specifications” and “General Notes”, must be shown on the plans, as well as all itemized quantities separated for facilities that will be Utility owned versus those that will not be Utility-owned. Utility’s logo, water owner information, Utility’s approval signature block and Record Drawing block shall be shown on the cover sheet of the plans.
7. If the plans cover Developer-owned facilities, a clear distinction between Utility-owned and Developer-owned facilities shall be made.
8. The plans must show the size and location of all water services and meters.
9. Waterlines shall be shown in profile with the appropriate elevations. Vertical deflections of waterlines shall be profiled regardless of size. Utility crossings of waterline shall be shown in profile and dimensioned for minimum clearances and/ or separations.
10. All referenced Utility details shall be shown on the plans. The appropriate detail shall be clearly referenced where the item is called out.
11. The plan shall show easements for Utility owned facilities on private property. Metes and bounds easement legal descriptions and exhibits signed and sealed by a Professional Land Surveyor licensed in the State of New Mexico shall be submitted on 8½” x 11” sheets with plans for approval, or 11” x 17” sheets for larger developments, as applicable.
12. Two copies of the Plan should be submitted to the Utility for approval.
13. An itemized engineer’s cost estimate for construction of Utility-owned facilities signed and sealed by a Professional Civil Engineer licensed in the State of New Mexico must be submitted with the plans. These estimates must be provided on 8½” x 11” sheets.
14. A site plan showing roadways and facilities must be provided on 8½” x 11” sheets, or 11” x 17” sheets for larger developments, as applicable.
15. Pipeline shall be located via roadway centerline stationing and centerline offset or pipeline centerline stationing.
16. The cover sheet shall contain an index map showing water facilities as well as the corresponding sheet number.



17. The following information shall be on the cover sheet of the drawings:

UTILITY OWNER INFORMATION
WATER OWNER/OPERATOR



EPCOR – Edgewood District
38 Cactus Road/PO Box 370
Edgewood, NM 87015
505-281-3294

18. Utility owner information with logo, Utility's General Notes, Material Specifications and Standard Details available in digital format.

GENERAL NOTES

1. All work and testing shall be in accordance with the New Mexico Standard Specifications for Public Works Construction, 2006 Edition as presently modified and updated unless otherwise stated on plans and approved by Utility.
2. Pipe, fittings, valves and fire hydrants shall conform to the latest standards issued by AWWA and/ or NSF, if such standards exist, and be acceptable to NMED. In the absence of such standards, materials meeting applicable product standards and acceptable to NMED may be selected. Special attention shall be given to selecting pipe materials which will protect against both internal and external pipe corrosion.
3. Water services 2 inches or smaller shall be in accordance with STD. DET. 342-2 or 342-6.
4. Fire hydrants shall be installed in accordance with STD. DET. 360-1 and 360-3, as indicated on the Plan.
5. Trenches shall be constructed in accordance with STD. DET. 350-1. For water lines which are twelve (12) inches and under, trench shall be constructed to provide support under full length of the barrel with hand excavated holes for couplings and/ or bells.
6. Water main separation and/ or extra protection shall be in accordance with NMED guidelines.
7. Changes from approved plans must be submitted to Utility for written approval prior to installation.
8. Contractor shall be responsible for obtaining required permits and inspections from appropriate governmental agencies for all work in public rights-of-way. Inspections by Utility do not relieve contractor of responsibility to obtain required inspections from other interested governmental agencies (Building Safety, Fire District, etc.)
9. Approved "Record Drawing" plans produced on 24" x 36" paper (2 copies) and electronic media (PDF format) certified by a Professional Civil Engineer licensed in the State of New Mexico will be required prior to Final Approval of water construction. The "Record Drawing" plans shall include the locations of all vertical and horizontal pipe bends, valves, manholes, water meters, etc., by station and offset (where necessary). For mapping purposes, a minimum of two (2) ties shall be made to northing and easting state plane coordinates with elevations shown on the plan. Coordinate system shall be NAD 83 and the elevation shall be NAVD 88. The "ties" shall include rotation and scale factor to convert the data from ground to grid.
10. Contractor shall notify Utility 48 hours in advance of any construction. When appointments for inspection are arranged at least 48 hours in advance, the inspection/ test will be conducted as scheduled, otherwise the request will be based upon availability.
11. An approved backflow prevention device shall be installed at all connections that pose a potential contamination of the drinking water distribution system. The recommendations contained in AWWA M14: Recommendation Practice for Backflow Prevention and Cross-Connection Control shall be followed and other requirements pursuant to Section 8.9.4 of the NMED Standards. All assemblies shall be installed in accordance with Utility standard details. No assembly shall be placed in service unless it has been tested and is functioning as designed. A certified test must be submitted to the Utility's Water Quality Specialist (Backflow Prevention) for approval. Operational approval of water facilities will not be granted prior to backflow prevention approval.



This Page Intentionally Left Blank

WATER SYSTEM MATERIAL SPECIFICATIONS

- Distribution Piping
- C900 Polyvinyl Chloride (PVC): In accordance with American Water Works Association (AWWA) Standard C900 for pipe diameters up to 12"; DR=18, elastomeric-gasket bell-end. Areas subjected to pressures greater than 100 psi shall be C900, DR=14.
 - C905 Polyvinyl Chloride (PVC): In accordance AWWA Standard C905 for pipe diameters greater than 12"; DR=18, elastomeric-gasket bell end.
 - Ductile iron pipe, mortar-lined (D.I.P.): In accordance AWWA Standards C150, C151 and C153. Equivalent O.D., Pressure Class 150 minimum. Mortar lining shall be in accordance AWWA C104. In corrosive soils, ductile iron pipe shall be polyethylene wrapped for the entire length in accordance with ANSI/AWWA C105/A21.5. Areas subjected to pressures greater than 100 psi shall be pressure class 200 minimum.
- Distribution fittings
- Standard fittings shall be ductile iron in accordance with ANSI/ AWWA C110/A21.10 with mechanical joints in accordance with ANSI/ AWWA C111/A21.11. Restraint glands are required for all fittings and shall be FORD Uni-Flange Series 1500.
- Water Line Valve
- Gate Valves 3" thru 12" shall be in accordance with AWWA Standard C509; valves > 12" shall be in accordance with AWWA Standard C515. Accepted Manufacturers and installation methods shall be in accordance with Utility's Detail 360-3.
 - Butterfly Valve in accordance with AWWA Standard C504 for valve sizes greater than 16". An operating manhole and by-pass valve are required for valves 24" or larger.
- Water Service
- Taps, pipe and fittings for water services through 2" size shall be in accordance with Utility STD. DET. 342-2, 342-3 and 342-6. Larger sizes to be submitted for approval. Minimum water service line size diameter shall be 3/4".
- Fire Hydrant
- Fire Hydrants shall be supplied with National Standard hose threads. Accepted Manufacturers and installation methods shall be in accordance with Utility's STD. DETAILS 360-1 and 360-3.
- All Other Items
- In accordance with AWWA Standards and/ or New Mexico Standard Specifications for Public Works Construction, 2006 Edition as presently modified and updated.



This Page Intentionally Left Blank

PLAT DEDICATION VERBIAGE

The following plat dedication verbiage shall be on the final recorded plat if Utility owned facilities are outside of dedicated right of ways and separate easements are not provided:

PERPETUAL WATER EASEMENT ('EASEMENT'), AS DESCRIBED IN THE PLAT ARE GRANTED TO EPCOR WATER NEW MEXICO INC., THEIR SUCCESSORS AND ASSIGNS (COLLECTIVELY, "GRANTEE"); TO CONSTRUCT, OPERATE, AND MAINTAIN WATER LINES AND APPURTENANT FACILITIES (COLLECTIVELY, "FACILITIES") UPON, ACROSS, OVER AND UNDER THE SURFACE OF THE EASEMENT; TOGETHER WITH THE RIGHT TO REPAIR, REPLACE, AND REMOVE THE FACILITIES FROM THE PREMISES; TO ADD OR TO ALTER THE FACILITIES; AND TO PROVIDE GRANTEE WITH REASONABLE INGRESS AND EGRESS TO THE FACILITIES. GRANTEE WILL HAVE UNRESTRICTED ACCESS TO THE EASEMENT FOR THE ACTIVITIES DESCRIBED ABOVE AND FORMAL NOTIFICATION OR APPROVAL BY ANY ASSOCIATION PRIOR TO ACCESSING THE EASEMENT WILL NOT BE REQUIRED.

GRANTOR SHALL NOT ERECT, CONSTRUCT OR PERMIT TO BE ERECTED OR CONSTRUCTED ANY BUILDING OR OTHER STRUCTURE WITHIN THE LIMITS OF THE EASEMENTS; PROVIDED, HOWEVER, GRANTOR SHALL HAVE THE RIGHT TO CONSTRUCT AND ERECT FENCES, TO INSTALL LANDSCAPING, PARKING FACILITIES AND DRIVEWAYS, AND TO ESTABLISH OTHER USES WHICH ARE NOT INCONSISTENT WITH USES WITHIN THE LIMITS OF SAID EASEMENTS IN A MANNER WHICH WILL NOT UNREASONABLY INTERFERE WITH GRANTEE'S ACCESS TO THE FACILITIES.

THIS EASEMENT IS GRANTED SUBJECT TO THE CONDITION THAT GRANTEE SHALL HOLD GRANTOR AND GRANTOR'S SUCCESSORS AND ASSIGNS HARMLESS FROM ANY AND ALL DAMAGES, CLAIMS, LIABILITIES OR EXPENSES WHICH MAY RESULT FROM GRANTEE'S USE OF THE EASEMENT. BY ACCEPTING THE EASEMENT, THE GRANTEE AGREES TO EXERCISE REASONABLE CARE TO AVOID DAMAGE TO THE PREMISES AND ALL PROPERTY THAT MAY AT ANY TIME BE THEREON.



This Page Intentionally Left Blank

“RECORD DRAWING” PLAN REVIEW REQUIREMENTS

1. Plans must include the following:
 - a. Station/ offset for all water fittings: including valves, tees, bends, all vertical and horizontal changes, etc.
 - b. Swing ties to fixed points are required for commercial projects that do not have a roadway centerline for stationing within a reasonable distance from the project.
 - c. Two full-size (24”x36”) paper copies of Record Drawings with each submittal until approved.
 - d. “Call outs” of all water pipe lengths between fittings and branches.
 - e. Elevations for all DIP sections regardless of the pipe diameter.
 - f. Record drawing profiles for all water lines 12” and larger.
 - g. Record drawing changes in pipe materials and sizes.
 - h. Correct street names, addresses and lot numbers.
2. Plans must be stamped and signed by a Professional Civil Engineer licensed in the State of New Mexico.
3. Written approval by Utility is required prior to submittal of Final Record Drawings.
4. Final Plans must be fully approved and signed by all required agencies.
5. Per Utility’s General Note number 9, record drawings must be received prior to final approval of water facilities. In addition, no refunds will be issued on facilities until record drawings and final acceptance has been granted.



This Page Intentionally Left Blank

WATER “RECORD DRAWING” CERTIFICATION

The following certification shall be on the cover sheet of the “Record Drawings”:

WATER “RECORD DRAWING” CERTIFICATION

I hereby certify that the “record drawing” measurements as shown hereon were made under my supervision or as noted, and are correct to the best of my knowledge and belief. Additionally, I hereby certify that all mains and services have been installed within the limits of easements dedicated to EPCOR Water New Mexico Inc., or inside dedicated street right-of-ways or public utility easements.

Seal

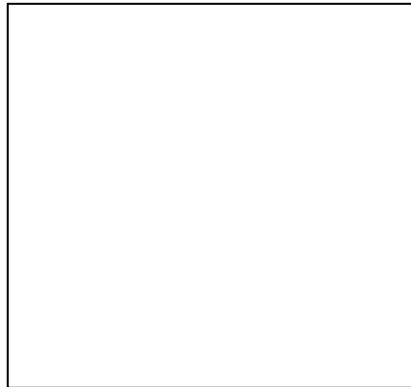



This Page Intentionally Left Blank



CHAPTER 4

CONSTRUCTION INSPECTION



This Page Intentionally Left Blank

PROCEDURE FOR SCHEDULING WATERLINE CONSTRUCTION INSPECTIONS

To schedule appointments, contact the Operations Manager at (505) 281-3294

NOTE: When appointments are arranged at least 48 hours in advance, the inspection/ test will be conducted as scheduled. When appointments are requested for the same day, the Construction Inspector will conduct the inspection/ test based upon his availability.

The Construction Inspector and the Contractor can schedule inspection of the following items in the field:

- Open trench before pipe is installed in trench
- After pipe, bends, fittings, joint restraints, etc. has been installed in trench, but before backfilling is started to verify position and type
- All waterlines-Inspections after select backfill (from bottom of trench to one [1] foot above pipe) has been placed into trench and properly compacted, installation of marking tape and prior to other backfilling of trench
- After each lift of backfill material have been placed into the trench and properly compacted
- Restrained fittings and valves
- Compaction testing
- Pressure test for tapping sleeve
- Pressure test for waterline
- Waterline chlorine injection
- Bacteriological sampling
- Operational Inspection, Final Inspection and re-inspection if required

NOTE: If Contractor proceeds with construction before having approval of Construction Inspector, Contractor will be required to expose the pipeline, valve, restrained fittings, etc., at no cost to Utility, to permit inspection by the Construction Inspector. The required exposure of pipeline by Contractor shall not deem acceptance of facility. Utility reserves the right to reject any facility not properly scheduled for inspection by Utility for any reason.



This Page Intentionally Left Blank



CHAPTER 5

BACKFLOW PREVENTION



This Page Intentionally Left Blank

PREMISES REQUIRING BACKFLOW PREVENTION

| Type of Assembly Required | DC | RP | PVB | AG | Type of Assembly Required | DC | RP | PVB | AG |
|--|----|----|-----|----|--|----|----|-----|----|
| Type of Business | | | | | Type of Business | | | | |
| Aircraft and Missile Plants | | X | | | Irrigation Systems (see standard details to determine) | | X | X | |
| Animal Clinics and Grooming | | X | | | Lab Using Contaminating Materials | | X | | |
| Automotive Plants | | X | | | Metal Manufacturing, Cleaning, Processing and Fabricating Plants | | X | | |
| Auxiliary Water Systems (interconnected) | | X | | | Mobile Home Parks | X | | | |
| Auxiliary Water Systems (non-interconnected) | X | | | | Motion Picture Studios | | X | | |
| Beverage Bottling Plants | | X | | | Multiple Services – Interconnected | X | | | |
| Breweries | | X | | | Oil and Gas Production, Storage or Transmission Properties | | X | | |
| Buildings Greater than 3 Stories or 34 feet High | X | | | | Paper and Paper Product Plants | | X | | |
| Buildings with Booster Pumps or Potable Water Storage | X | | | | Plating Plants | | X | | |
| Buildings with Landscape Fountains, Ponds, or Baptismal Tanks | | X | | X | Power Plants | | X | | |
| Buildings with Sewer Ejectors | | X | | | Radioactive Materials Handling | | X | | |
| Canneries, Packing Houses and Reduction Plants | | X | | | Restaurants | | X | | |
| Car Wash Facilities | | X | | | Restricted, Classified or Other Closed Facility | | X | | |
| Centralized Heating and Air Conditioning Plants | | X | | | Rubber Plants | | X | | |
| Chemical Plants | | X | | | Sand and Gravel Plants | | X | | |
| Chemically Treated Potable or Non-potable Water Systems | | X | | | Sanitariums, Nursing and Convalescent Homes | | X | | |
| Civil Works | | X | | | Schools and Colleges | | X | | |
| Commercial Laundries | | X | | | Sewage and Storm Drain Facilities, Reclaimed Water | | X | | X |
| Dairies and Cold Storage Plants | X | | | | Shopping Centers | X | | | |
| Dye Works | | X | | | Water Trucks, Water Tanks, Hydraulic Sewer Cleaning Equipment | | X | | X |
| Film Processing Labs | | X | | | Fire System Requirements | | | | |
| Food Processing Plants | X | | | | Class 1 & 2 | X | | | |
| Holding Tank Disposal Stations | | X | | | Class 3 – 6 | | X | | |
| Hospitals, Medical Bldgs., Morgues, Mortuaries, Autopsy Facilities | | X | | | Any Questions or variance requests should be directed to the Operations Manager, Tom Torres 505-281-3294 | | | | |

DC = Double Check Assembly
 RP = Reduced Pressure Assembly
 PVB = Pressure Vacuum Breaker Assembly
 AG = Air Gap



This Page Intentionally Left Blank



CHAPTER 6

STANDARD DETAILS



This Page Intentionally Left Blank

TABLE OF CONTENTS – DETAILS

| Detail Name | Detail No. |
|---|-------------------|
| (Residential) Potable Water Service Connection | 342-2 |
| New Service Details (3/4" and 1") | 342-3 |
| Service Transfer Detail | 342-4 |
| Meter Can Assembly | 342-5 |
| 1-1/2" and 2" Potable Water Service Connection | 342-6 |
| Well or Booster Station Discharge Meter | 342-8 |
| Pressure Reducing Valve (PRV) Vault | 346-1 |
| Pipe Trench Detail | 350-1A |
| Pipe Trench Detail | 350-1B |
| Potable Combination Air Release Valve Offset, 1" or 2" | 351-1 |
| Potable Underground Combination Air Release Valve Over Line, 1" or 2" | 351-2 |
| Fire Hydrant Installation, Standard | 360-1 |
| Washout Assembly Detail | 360-2 |
| Valve and Box Detail | 360-3 |
| Casing Details | 360-4 |
| Pavement Patch Detail | 360-5 |
| Typical Bollard Detail | 360-6 |
| Typical Hot Tap Connection Detail | 360-7 |
| Water Sampling Station | 390-1 |

This Page Intentionally Left Blank

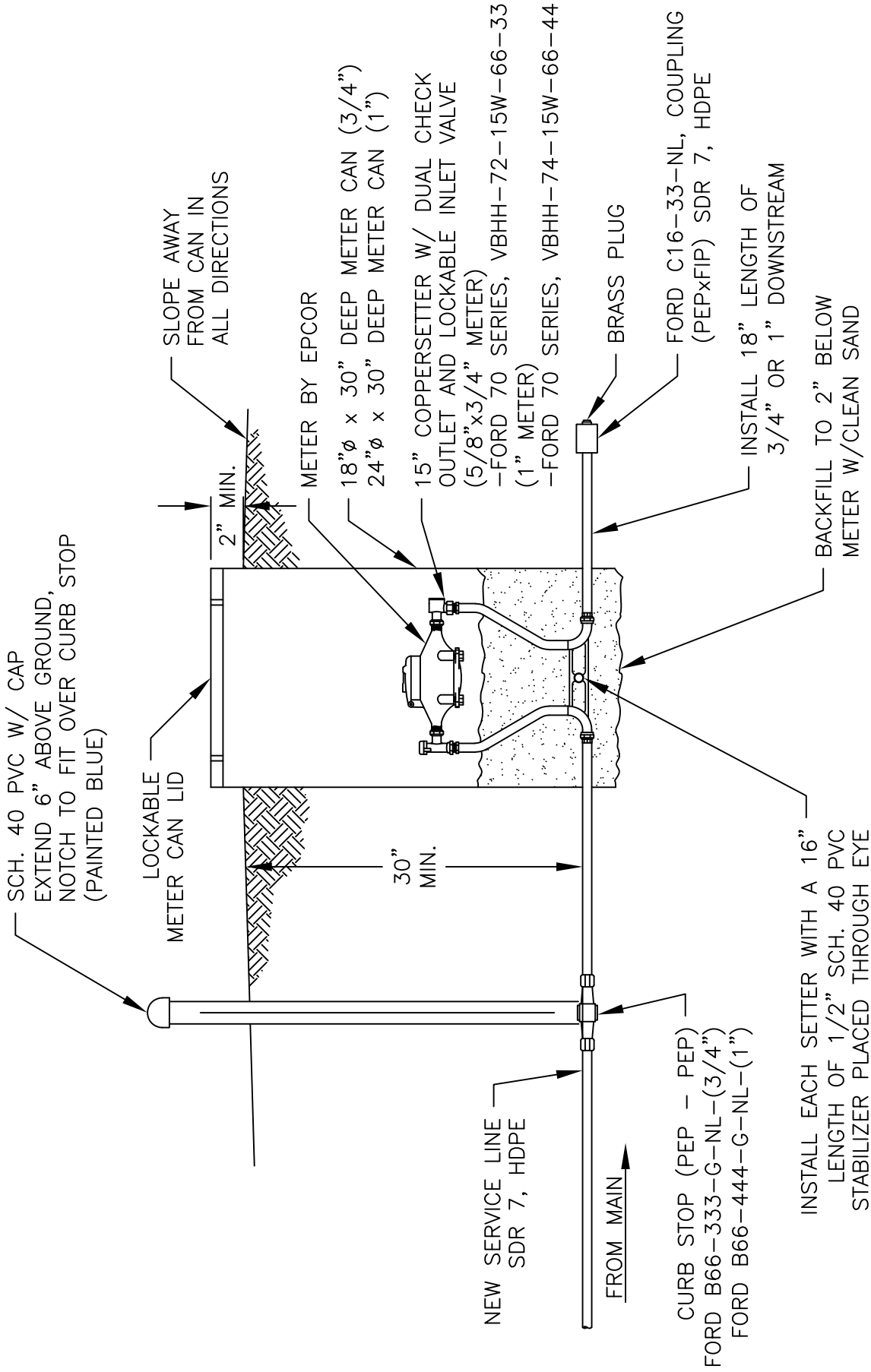

| | | | |
|-------------------|--------------------|--|---------------------|
| DATE: 06/09/18 | EPCOR WATER | (RESIDENTIAL) POTABLE WATER SERVICE CONNECTION 3/4" AND 1" | DETAIL NO. 342-2 |
|-------------------|--------------------|--|---------------------|

This Page Intentionally Left Blank

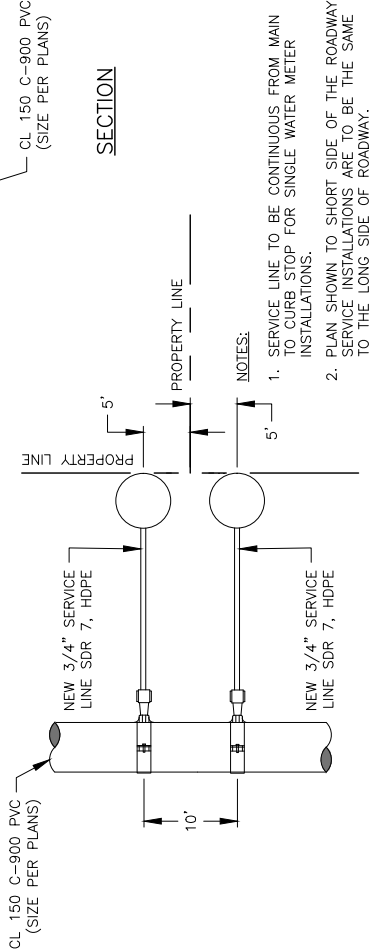
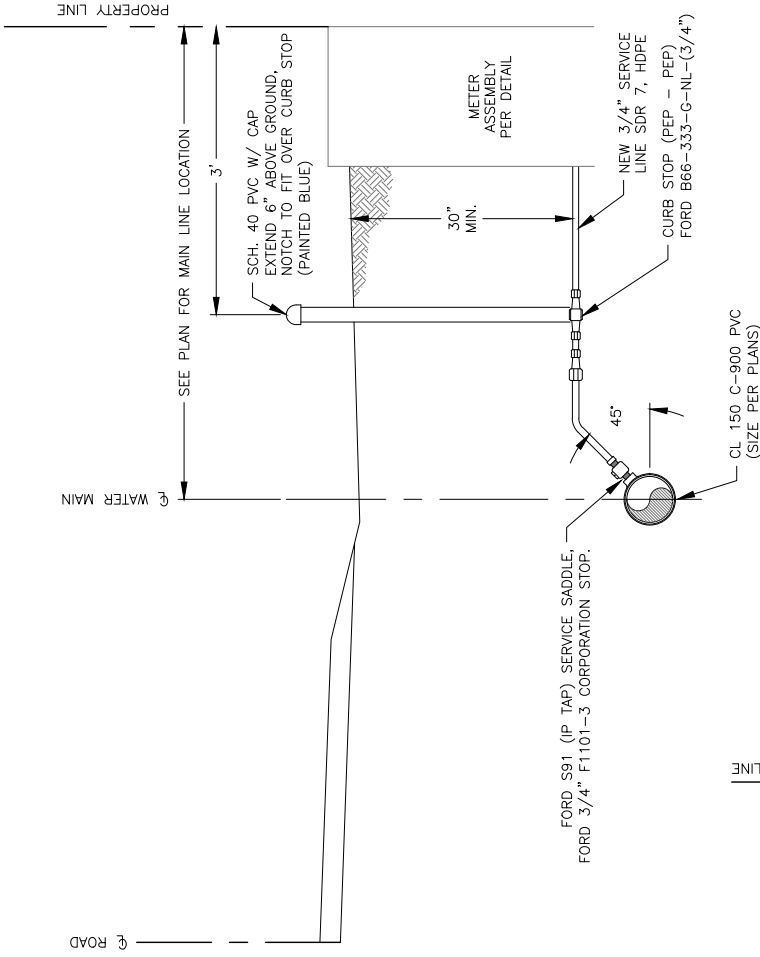

SECTION

- NOTES:
1. SERVICE LINE TO BE CONTINUOUS FROM MAIN TO CURB STOP FOR SINGLE WATER METER INSTALLATIONS.
 2. PLAN SHOWN TO SHORT SIDE OF THE ROADWAY, SERVICE INSTALLATIONS ARE TO BE THE SAME TO THE LONG SIDE OF ROADWAY.

PLAN

DETAIL NO.
342-3

NEW SERVICE DETAILS 3/4"



DATE:
10/25/19

This Page Intentionally Left Blank

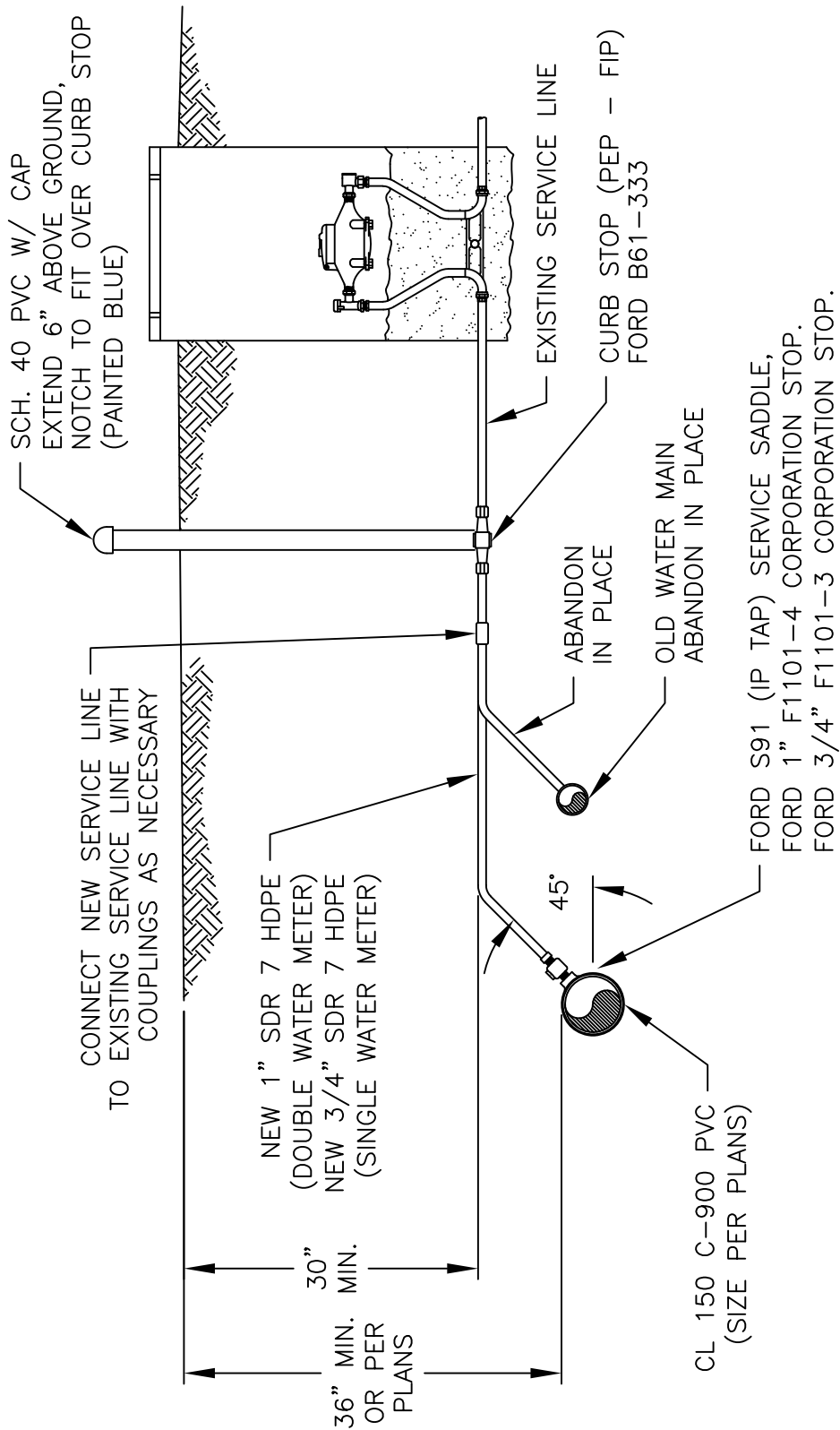

NOTES:

1. MISCELLANEOUS SERVICE LINE FITTINGS SHALL CONFORM TO AWWA SPECIFICATION C800 AS MANUFACTURED BY: FORD METER BOX, MUELLER, AND A.Y. MCDONALD (NO EXCEPTIONS)
2. IF EXISTING SERVICE DOES NOT HAVE A CURB STOP INSTALLED, THEN A CURB STOP SHALL BE INSTALLED AS SHOWN, AND THE CONNECTION TO THE EXISTING SERVICE LINE SHALL BE MADE BETWEEN THE NEW CURB STOP AND THE EXISTING METER.

DATE:

06/09/18

EPCOR WATER

SERVICE TRANSFER DETAIL

DETAIL NO.

342-4

This Page Intentionally Left Blank

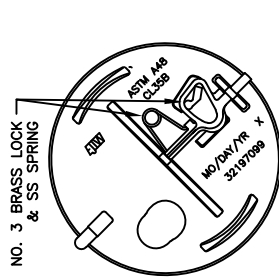
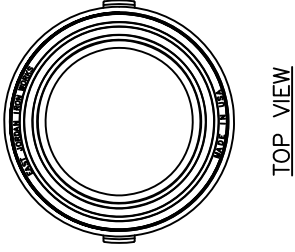
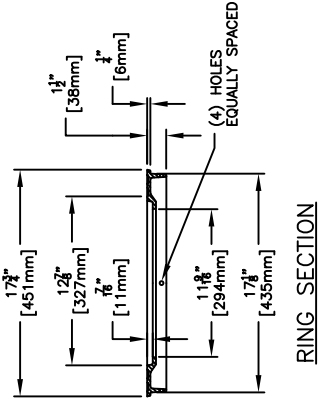
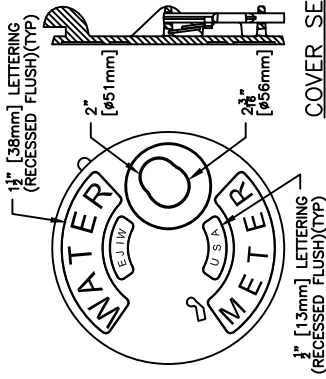

RING & COVER
CATALOG NO.: TOUCH READ CV W/ LOCK
MAT'L: GRAY IRON ASTM A48 CL35B

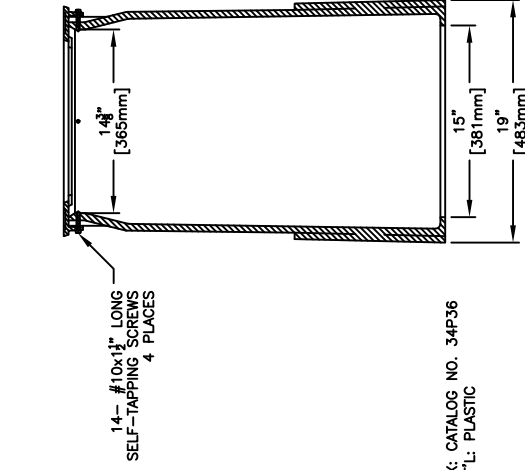
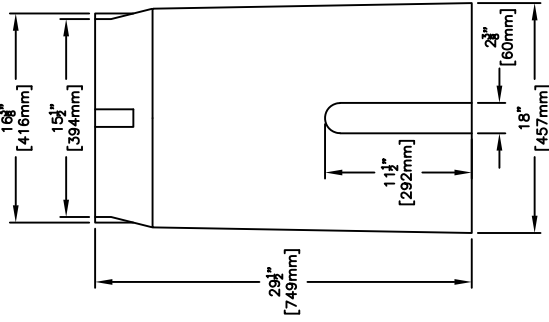

BOX: CATALOG NO. 34P36
MAT'L: PLASTIC

COVER SECTION

SIDE VIEW ROTATED 45°

BOX SECTION

DATE:
06/09/18



METER CAN ASSEMBLY
MANUFACTURER: EAST JORDAN IRON WORKS, INC.
PO BOX 439, EAST JORDAN, MI 49727
1-800-874-4100

DETAIL NO.
342-5

This Page Intentionally Left Blank

EPCOR
DEVELOPMENT GUIDE

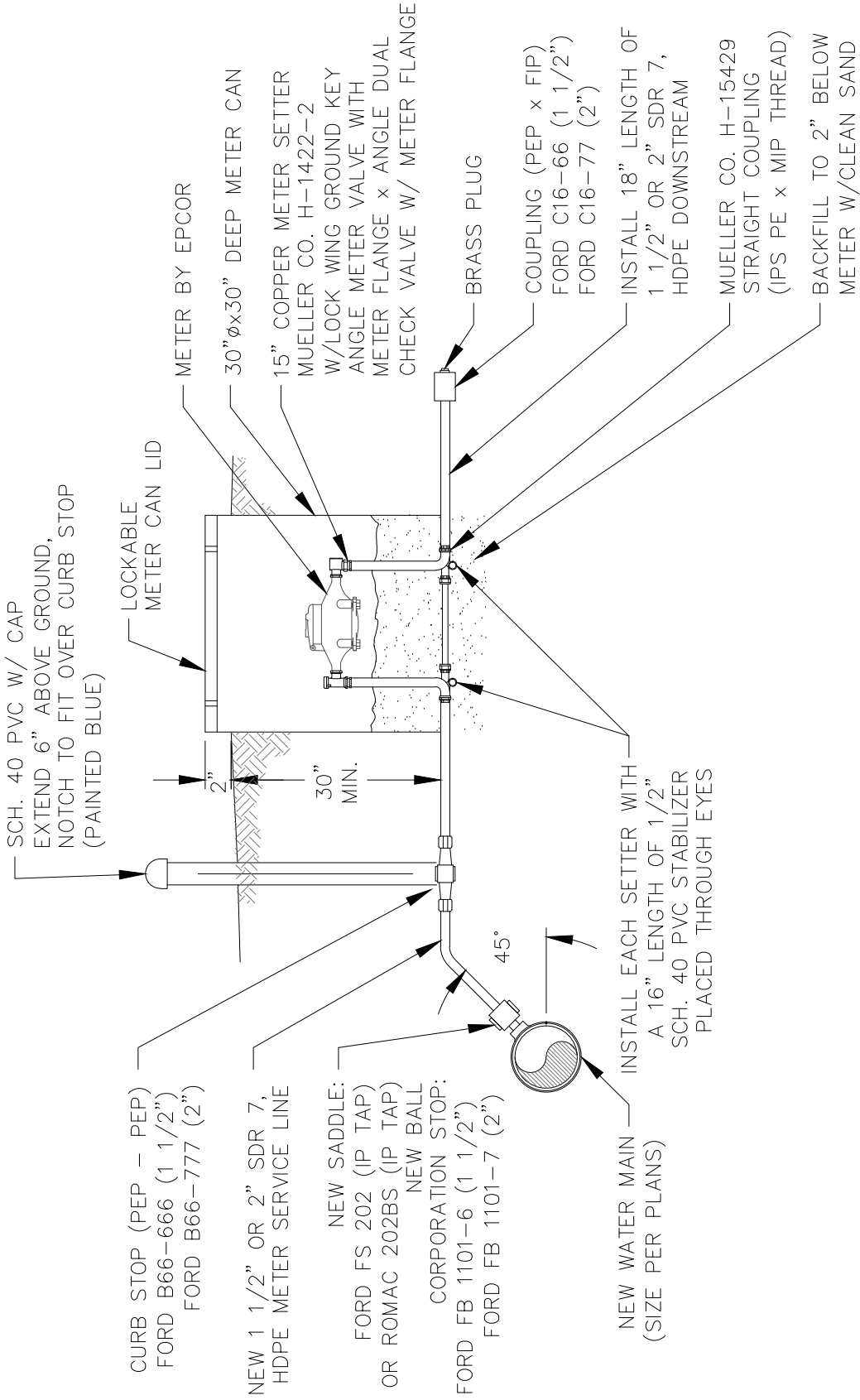

DATE:
06/09/18

EPCOR WATER

1 1/2" AND 2" POTABLE
WATER SERVICE CONNECTION

DETAIL NO.
342-6



This Page Intentionally Left Blank

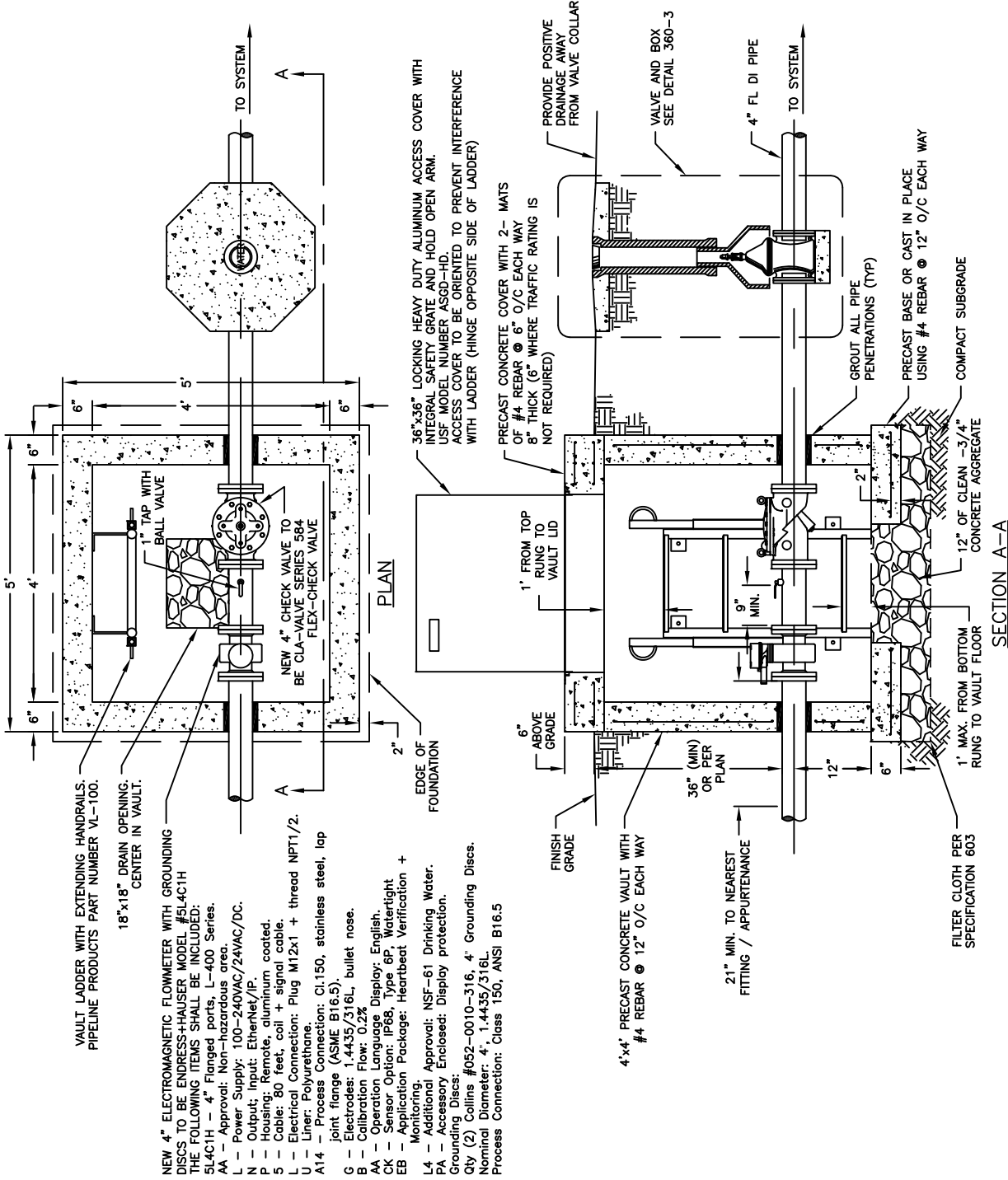

VAULT LADDER WITH EXTENDING HANDRAILS.
PIPELINE PRODUCTS PART NUMBER VL-100.

18"x18" DRAIN OPENING,
CENTER IN VAULT.

NEW 4" ELECTROMAGNETIC FLOWMETER WITH GROUNDING
DISCS TO BE ENDRESS+HAUSER MODEL #5L4C1H

THE FOLLOWING ITEMS SHALL BE INCLUDED:

5L4C1H - 4" Flanged ports, L-400 Series.

AA - Approval: Non-hazardous area.

L - Power Supply: 100-240VAC/24VAC/DC.

N - Output; Input: EtherNet/IP.

P - Housing: Remote, aluminum coated.

S - Cable: 80 feet, coil + signal cable.

L - Electrical Connection: Plug M12x1 + thread NPT1/2.

U - Liner: Polyurethane.

A14 - Process Connection: CI:150, stainless steel, lap
joint flange (ASME B16.5).

G - Electrodes: 1.4435/316L, bullet nose.

B - Calibration Flow: 0.2%

AA - Operation Language Display: English.

CK - Sensor Option: IP68, Type 6P, Watertight

EB - Application Package: Heartbeat Verification +
Monitoring.

L4 - Additional Approval: NSF-61 Drinking Water.

PA - Accessory Enclosed: Display protection.

Grounding Discs:

Qty (2) Collins #052-0010-316, 4" Grounding Discs.

Nominal Diameter: 4", 1.4435/316L.

Process Connection: Class 150, ANSI B16.5

| | | | |
|-------------------|-------------|--|---------------------|
| DATE: 06/09/18 | EPCOR WATER | WELL OR BOOSTER STATION DISCHARGE METER | DETAIL NO. 342-8 |
|-------------------|-------------|--|---------------------|

This Page Intentionally Left Blank

NOTES:

1. CONCRETE TO BE 3000 PSI MINIMUM.
2. PROVIDE POSITIVE DRAINAGE AWAY FROM VAULT.
3. ALL VALVES, PIPING, CONCRETE, AND OTHER AFFIXMENTS (SHOWN OR NOT) REQUIRED TO PROVIDE A COMPLETE AND WORKING PRESSURE REDUCING VALVE AND VAULT ASSEMBLY ARE TO BE INCLUDED.

KEYED NOTES:

1. PRECAST CONCRETE COVER WITH 2- MATS OF #4 REBAR @ 6" O/C EACH WAY. 8" THICK (6" WHERE TRAFFIC RATING IS NOT REQUIRED.)
2. PRECAST CONCRETE VAULT WITH #4 REBAR @ 12" O/C EACH WAY.
3. PRECAST BASE OR CAST IN PLACE USING #4 REBAR @ 12" O/C EACH WAY.
4. EDGE OF FOUNDATION BELOW.
5. 36"x60" LOCKING HEAVY DUTY ALUMINUM ACCESS COVER WITH 4"x4"x1/2" INCHES THICK 1/2" ALUMINUM FRAME. NUMBER ASSIGNED. ACCESS COVER TO BE ORIENTED TO PREVENT INTERFERENCE WITH LADDER (HINGE OPPOSITE SIDE OF LADDER).
6. VAULT LADDER WITH EXTENDING HANDRAILS: PIPELINE PRODUCTS PART #1000. LADDER AND HANDRAILS TO BE 5" MAX. INSTALL PER MANUFACTURER'S RECOMMENDATIONS.
7. FILTER CLOTH AS SHOWN.
8. 1"x5" DRAIN OPENING; CENTER IN VAULT.
9. 12" OF 3/4" CLEAN CONCRETE AGGREGATE.
10. COMPACT SUBGRADE TO 95% ASTM D-1557.
11. GROUT ALL PIPE PROTRUSIONS (TYP).
12. NEW C-400 PVC CL 150 (SIZE PER PLANS)
13. BURIED END
14. VERTICAL PIPE STANDS.
15. MJ GATE VALVE. INSTALL PER DETAIL 360-3.
16. DIP PIPE SPOOL. FLAPE.
17. FL. TEE.
18. FL. GATE VALVE WITH HAND WHEEL.
19. FL. REDUCER.
20. EL. PRV: CLA-VAL MODEL #R2G-01
PRV SHALL INCLUDE THE FOLLOWING OPTIONS:
B- 2" ISOLATION VALVE
C- 1" PRESSURE GAUGE
Y- 1/2" STRAINER ON INLET
P- X141 PRESSURE GAUGE
C- 1" PRESSURE GAUGE
C- 1" FLOW CONTROL (ONLY ON VALVES SMALLER THAN 6")
KK- EPOXY COATING
KK- STAINLESS STEEL TUBING AND TRIM
21. FL. GATE VALVE WITH HAND WHEEL.
22. DIP PIPE SPOOL. FLAPE.
23. FL. BEND.
24. DIP PIPE SPOOL. FLAPE.
25. FL. REDUCER.
26. EL. PRV: CLA-VAL MODEL #R2G-01
PRV SHALL INCLUDE THE FOLLOWING OPTIONS:
B- 2" ISOLATION VALVE
C- 1" PRESSURE GAUGE
Y- 1/2" STRAINER ON INLET
P- X141 PRESSURE GAUGE
V- X101 VALVE POSITION INDICATOR
C- 1" FLOW CONTROL (ONLY ON VALVES SMALLER THAN 6")
KK- EPOXY COATING
KK- STAINLESS STEEL TUBING AND TRIM
27. PRESSURE TRANSDUCER ASSEMBLY:
1- PVC BALL VALVE
2- 1" SCH. 80 PVC NIPPLES
3- 1" SCH. 80 PVC CAP
SO ALL FITTINGS TO BE THREADED
28. 1" COMBINATION TRANSDUCER ASSEMBLY:
1- FORD SERVICE SADDLE OR ENGINEER APPROVED EQUAL
1- PVC BALL VALVE
1- 1/4" BUSHING
1- "BARAK" D-040 1" COMBINATION AIR VALVE. NO SUBSTITUTIONS.
29. 4" THREADED STEEL PIPE WITH GOODSHECK AND INSET SCREEN FOR AIR VALVE
30. OFFSET SUPPORT - GRINNELL FIGURE 103 OR ENGINEER APPROVED EQUAL.
31. 4"x6" BOLLARD PER DETAIL 360-6.
32. ELECTRIC RACK BY EPFOR.

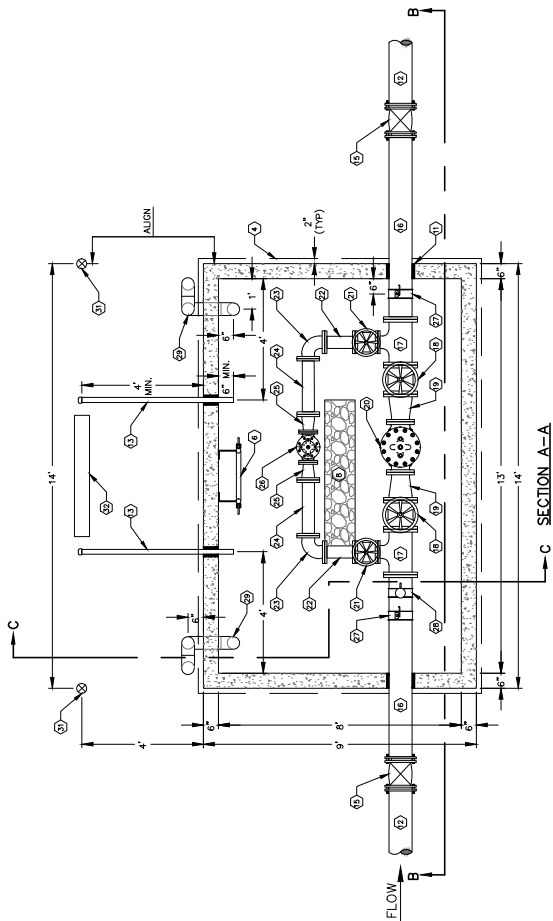

C SECTION A-A

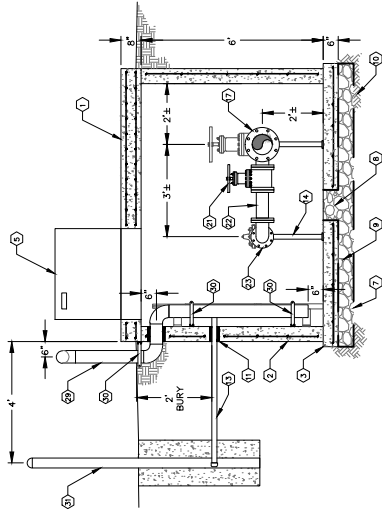

SECTION C-C

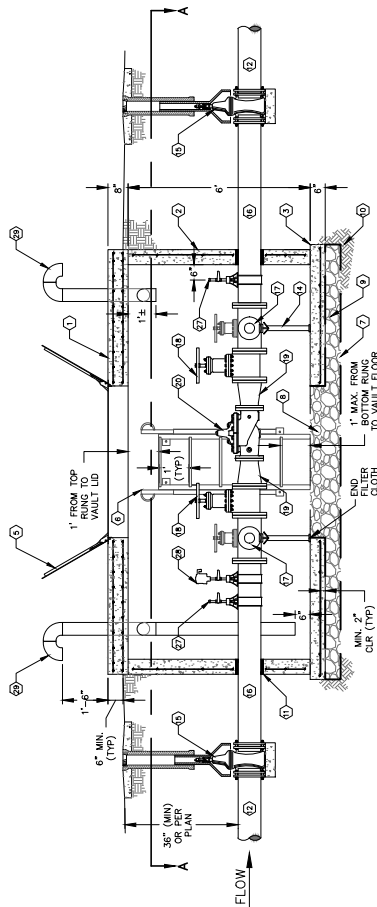

SECTION B-B

DETAIL NO.
346-1

PRESSURE REDUCING
VALVE (PRV) VAULT



DATE:
06/09/18

This Page Intentionally Left Blank

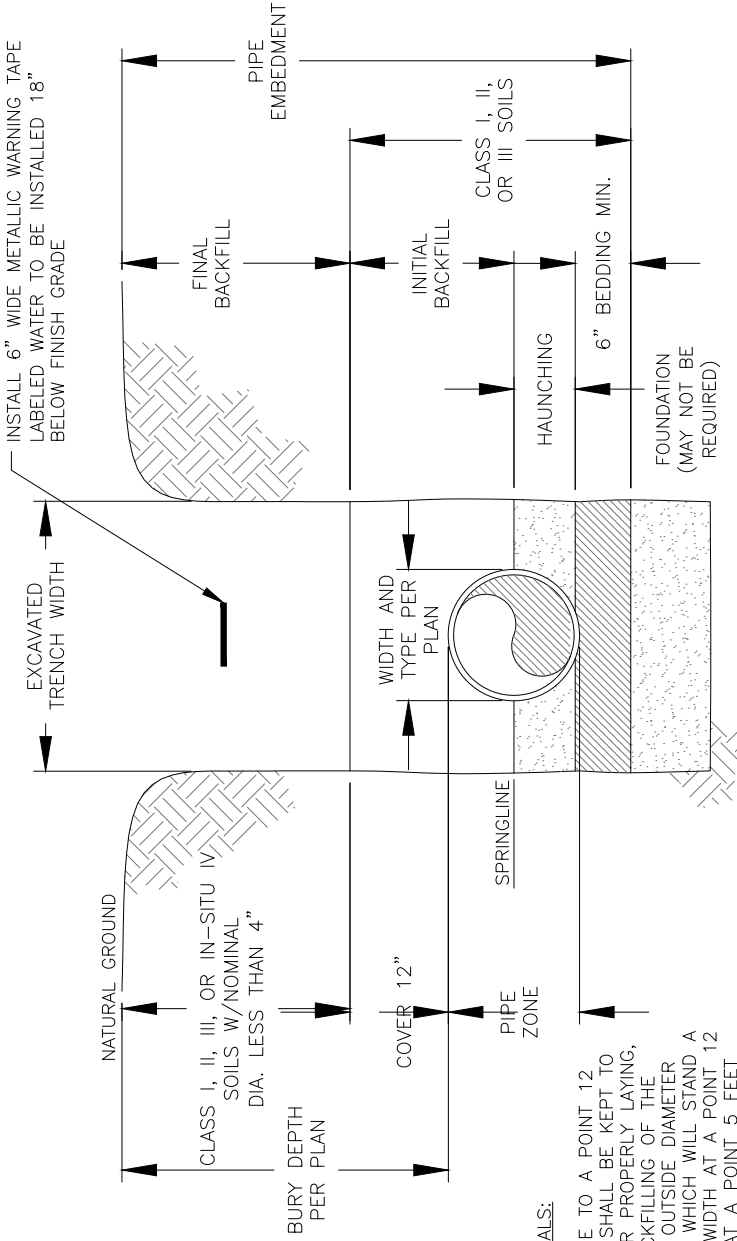

TRENCH WIDTH FOR RIGID PIPE MATERIALS:

TRENCH WIDTHS FROM BOTTOM OF PIPE TO A POINT 12 INCHES ABOVE THE TOP OF THE PIPE SHALL BE KEPT TO THE PRACTICAL MINIMUM REQUIRED FOR PROPERLY LAYING, ALIGNING, GRADING, JOINTING, AND BACKFILLING OF THE PIPE, BUT NO LESS WIDTH THAN PIPE OUTSIDE DIAMETER PLUS 16 INCHES. FOR STABLE SOILS WHICH WILL STAND A VERTICAL CUT, THE MAXIMUM TRENCH WIDTH AT A POINT 12 INCHES ABOVE THE TOP OF PIPE OR AT A POINT 5 FEET ABOVE THE BOTTOM OF THE TRENCH, WHICHEVER IS LESS, SHALL BE AS FOLLOWS:

- THE PIPE OUTSIDE DIAMETER PLUS 2 FEET FOR PIPES 27 INCHES IN DIAMETER AND SMALLER.
- 1.6 TIMES THE NOMINAL DIAMETER FOR PIPES 30 INCHES IN DIAMETER OR LARGER.

WHEN SOIL WILL NOT STAND VERTICAL, THE TRENCH SIDES SHALL BE SLOPED TO PROVIDE NOT LESS THAN THE OUTSIDE DIAMETER PLUS 16 INCHES AT THE PIPE INVERT.

TRENCH WIDTH FOR NON-RIGID PIPES:

THE MINIMUM CLEAR WIDTH OF THE TRENCH MEASURED AT THE SPRINGLINE OF THE PIPE SHOULD BE 1 FOOT GREATER THAN THE OUTSIDE DIAMETER OF THE PIPE. THE MAXIMUM CLEAR WIDTH OF THE TRENCH AT A POINT 1 FOOT ABOVE THE TOP OF THE PIPE IS EQUAL TO THE PIPE OUTSIDE DIAMETER PLUS 2 FEET. IF THE MAXIMUM RECOMMENDED TRENCH WIDTH MUST BE EXCEEDED OR IF THE PIPE IS INSTALLED IN A COMPACTED EMBANKMENT, THE PIPE EMBEDMENT SHOULD BE COMPACTED TO A POINT OF AT LEAST 2-1/2 PIPE DIAMETERS FROM THE SIDE OF THE PIPE OF TO THE TRENCH WALLS.

A1 TYPICAL TRENCH SECTION

SCALE: NONE

GENERAL NOTE:

1. TRENCH EXCAVATION, BACKFILL, AND SAFETY SHALL BE IN ACCORDANCE WITH OSHA STANDARDS 29 CFR PART 1926 SUBPART P, OR ANY APPLICABLE AMENDMENTS
2. CLASS V SOILS ARE NOT ACCEPTABLE IN FINAL BACKFILL.
3. SEE SHEET 350-1B FOR SOIL CLASSIFICATION DESCRIPTIONS.
4. MECHANICAL TAMPERS SHALL NOT BE USED IN THE INITIAL BACKFILL REGION FOR FLEXIBLE PIPE. WHEN FLEXIBLE PIPE IS USED CONTRACTOR SHALL, PRIOR TO THE START OF CONSTRUCTION, PROVIDE THE PROPOSED COMPACTION METHOD IN THE INITIAL BACKFILL REGION TO THE ENGINEER FOR APPROVAL.

DATE:

06/09/18



PIPE TRENCH DETAIL

DETAIL NO.

350-1A

This Page Intentionally Left Blank

| SOILS CLASS | SOIL TYPE | DESCRIPTION |
|--------------------|-----------|--|
| CLASS I SOILS* | | MANUFACTURED ANGULAR, GRANULAR MATERIAL, 1/4 TO 1-1/2 INCHES (6 TO 40 mm) SIZE, INCLUDING MATERIALS HAVING REGIONAL SIGNIFICANCE SUCH AS CRUSHED STONE OR ROCK, BROKEN CORAL, CRUSHED SLAG, CINDERS, OR CRUSHED SHELLS, COMPLYING TO THE REQUIREMENTS OF CLASS II SOILS. |
| CLASS II SOILS** | GW | WELL-GRADED GRAVELS AND GRAVEL-SAND MIXTURES, LITTLE OR NO FINES. 50% OR MORE OF COARSE FRACTION RETAINED ON NO.4 SIEVE. MORE THAN 95% RETAINED ON NO. 200 SIEVE. CLEAN. |
| CLASS II SOILS** | GP | POORLY GRADED GRAVELS AND GRAVEL-SAND MIXTURES, LITTLE OR NO FINES. 50% OR MORE OF COARSE FRACTION RETAINED ON NO. 4 SIEVE.MORE THAN 95% RETAINED ON NO. 200 SIEVE. CLEAN. |
| CLASS II SOILS** | SW | WELL-GRADED ANDS AND GRAVELLY SANDS, LITTLE OR NO FINES. MORE THAN 50% COARSE FRACTION PASSES NO. 4 SIEVE. MORE THAN 95% RETAINED ON NO. 200 SIEVE. CLEAN. |
| CLASS II SOILS** | SP | POORLY GRADED SANDS AND GRAVELLY SANDS, LITTLE OR NO FINES. MORE THAN 50% OF COARSE FRACTION PASSES NO.4 SIEVE. MORE THAN 95% RETAINED ON NO. 200 SIEVE. CLEAN. |
| CLASS III SOILS*** | GM | SILTY GRAVELS, GRAVEL-SAND-SILT MIXTURES. 50% OR MORE OF COARSE FRACTION RETAINED ON NO. 4 SIEVE.MORE THAN 50% RETAINED ON NO. 200 SIEVE. |
| CLASS III SOILS*** | GC | CLAYEY GRAVELS, GRAVEL-SAND-CLAY MIXTURES. 50% OR MORE OF COARSE FRACTION RETAINED ON NO. 4 SIEVE. MORE THAN 50% RETAINED ON NO. 200 SIEVE. |
| CLASS III SOILS*** | SM | SILTY SANDS, SAND-SILT MIXTURES. MORE THAN 50% OF COARSE FRACTION PASSES NO. 4 SIEVE. MORE THAN 50% RETAINED ON NO. 200 SIEVE. |
| CLASS III SOILS*** | SC | CLAYEY SANDS, SAND-CLAY MIXTURES. MORE THAN 50% OF COARSE FRACTION PASSES NO. 4 SIEVE. MORE THAN 50% RETAINED ON NO. 200 SIEVE. |
| CLASS IV SOILS | ML | INORGANIC SILTS, VERY FINE SANDS, ROCK FLOUR, SILTY OR CLAYEY FINE SANDS. LIQUID LIMIT 50% OR LESS. 50% OR MORE PASSES NO. 200 SIEVE. |
| CLASS IV SOILS | CL | INORGANIC CLAYS OR LOW TO MEDIUM PLASTICITY, GRAVELLY CLAYS, SANDY CLAYS, SILTY CLAYS, LEAN CLAYS. LIQUID LIMITY 50% OR LESS 50% OR MORE PASSES NO. 200 SIEVE. |
| CLASS IV SOILS | MH | INORGANIC SILTS, MICACEOUS OR DIATOMACEOUS FINE SANDS OR SILTS, ELASTIC SILTS. LIQUID LIMITY GREATER THAN 50%. 50% OR MORE PASSES NO. 200 SIEVE. |
| CLASS IV SOILS | CH | INORGANIC CLAYS OF HIGH PLASTICITY, FAT CLAYS. LIQUID LIMIT GREATER THAN 50%. 50% OR MORE PASSES NO. 200 SIEVE. |
| CLASS V SOILS | OL | ORGANIC SILTS AND ORGANIC SILTY CLAYS OF LOW PLASTICITY. LIQUID LIMIT 50% OR LESS. 50% OR MORE PASSES NO. 200 SIEVE. |
| CLASS V SOILS | OH | ORGANIC CLAYS OF MEDIUM TO HIGH PLASTICITY. LIQUID LIMIT GREATER THAN 50%. 50% OR MORE PASSES NO. 200 SIEVE. |
| CLASS V SOILS | PT | PEAT, MUCH AND OTHER HIGHLY ORGANIC SOILS. |

DATE:

06 / 09 / 18



PIPE TRENCH DETAIL

DETAIL NO.

350-1B

This Page Intentionally Left Blank

CONTRACTOR TO INSTALL CARSONITE MARKER AT EACH CAV, AND AS INDICATED ON THE PLANS. MARKER TO BE BLUE RHINO TRIVIEW FLEX. USA BLUE BOOK STOCK #70450

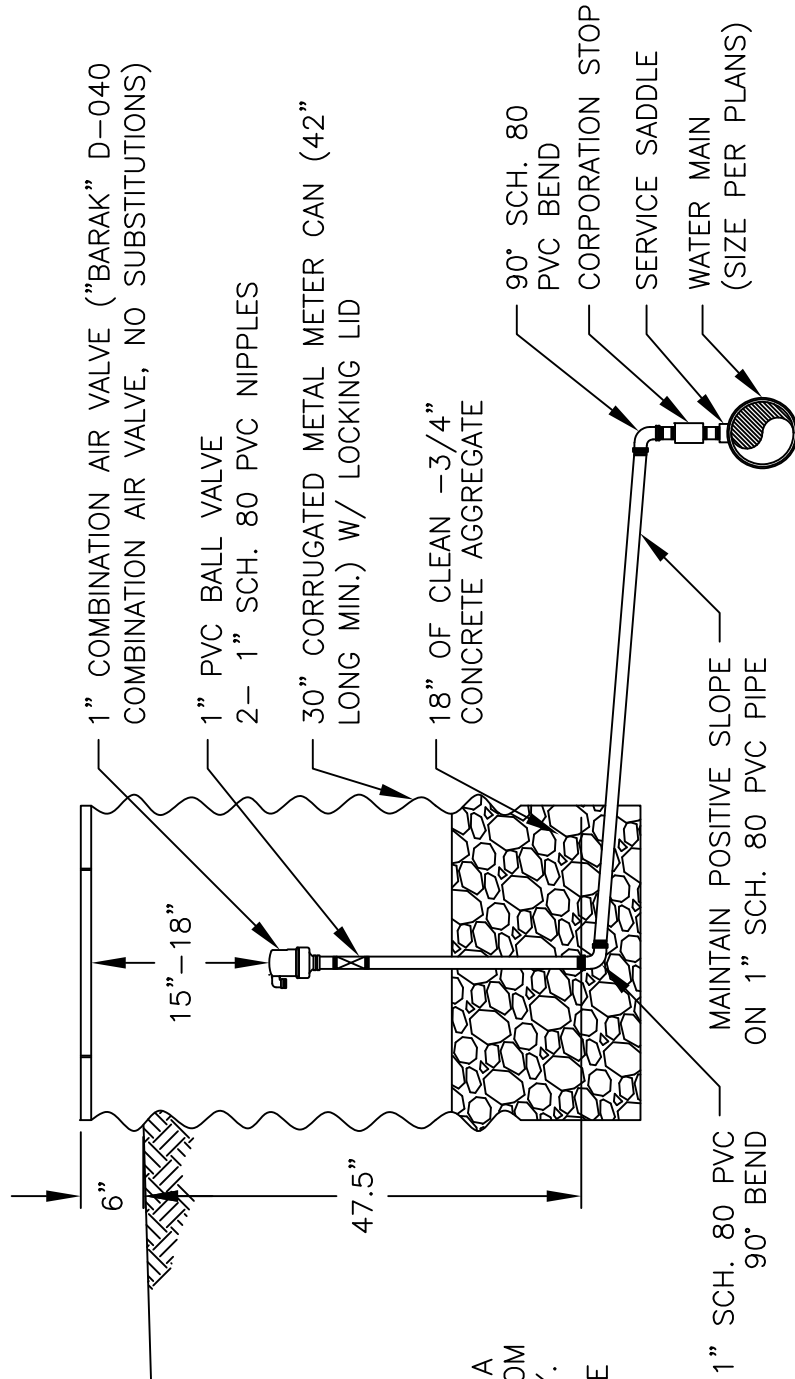

NOTES:

1. LOCATE AIR VALVE A SAFE DISTANCE FROM TRAVELED ROADWAY.
2. ALL FITTINGS TO BE THREADED.

DATE:

06/09/18



POTABLE COMBINATION AIR RELEASE
VALVE OFFSET, 1" OR 2" (1" SHOWN)

DETAIL NO.

351-1



This Page Intentionally Left Blank



CONTRACTOR TO INSTALL CARBONITE MARKER AT EACH CAV, AND AS INDICATED ON THE PLANS. MARKER TO BE BLUE RHINO TRVIEW FLEX. USA BLUE BOOK STOCK #70450

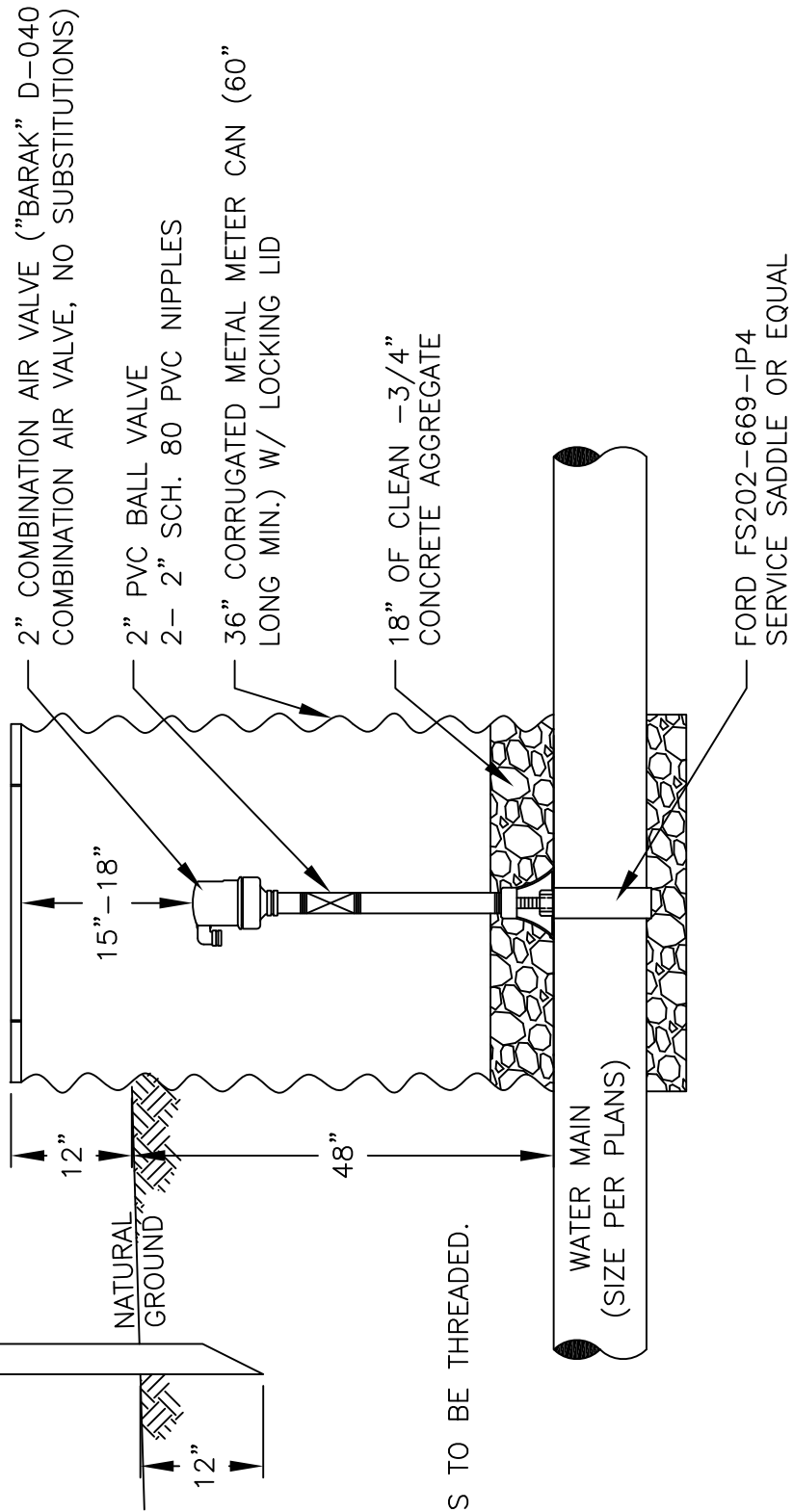

NOTES:

1. ALL FITTINGS TO BE THREADED.

DATE:

06/09/18



POTABLE UNDERGROUND
COMBINATION AIR RELEASE VALVE
OVER LINE, 1" OR 2" (2" SHOWN)

DETAIL NO.

351-2



This Page Intentionally Left Blank

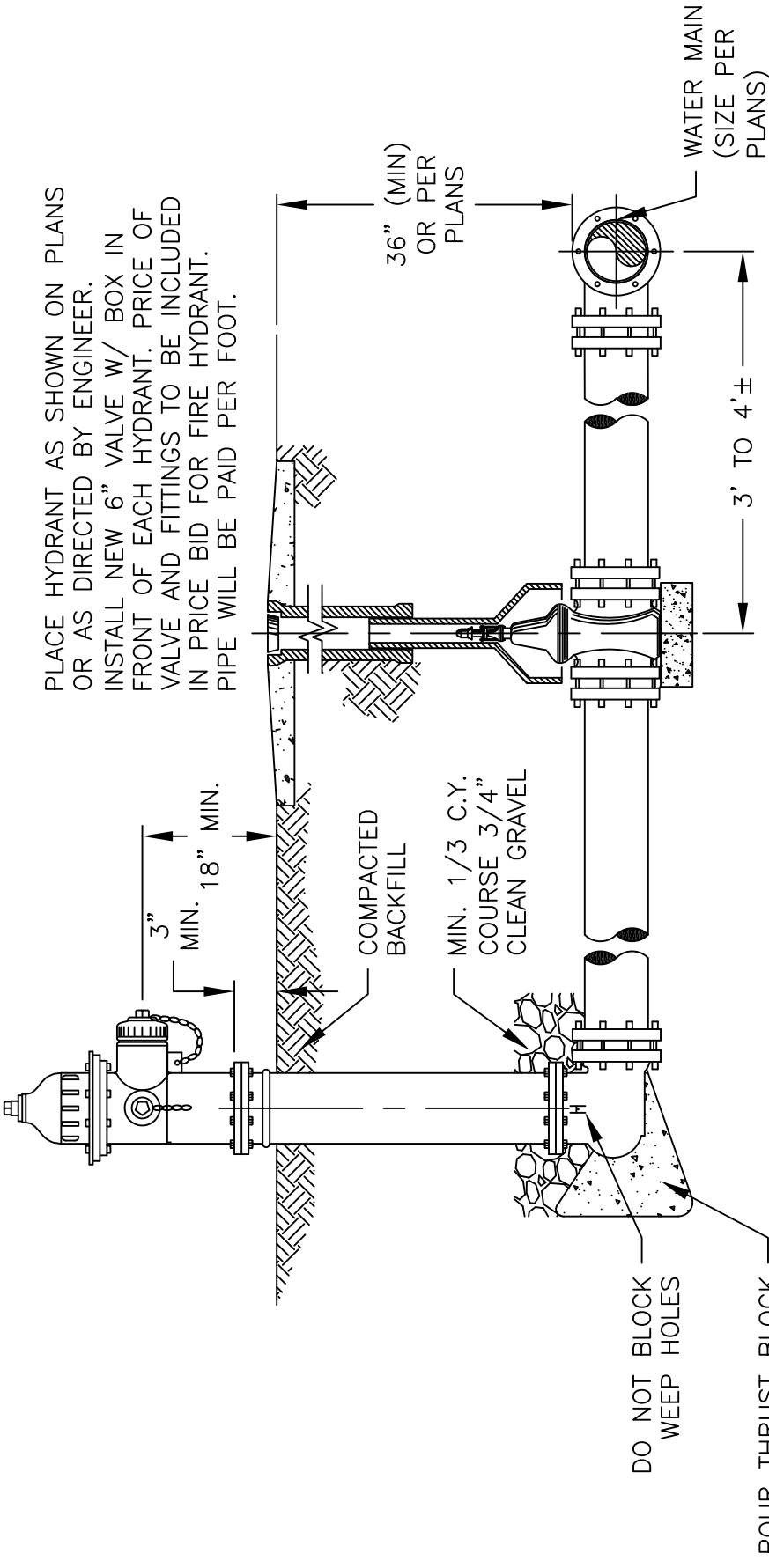

PLACE HYDRANT AS SHOWN ON PLANS OR AS DIRECTED BY ENGINEER. INSTALL NEW 6" VALVE W/ BOX IN FRONT OF EACH HYDRANT. PRICE OF VALVE AND FITTINGS TO BE INCLUDED IN PRICE BID FOR FIRE HYDRANT. PIPE WILL BE PAID PER FOOT.

DO NOT BLOCK WEEP HOLES

POUR THRUST BLOCK AGAINST FIRM UNDISTURBED SOIL. MIN. 2.7 SQ. FT. BEARING SURFACE FOR 6" LINE

NOTE:

HYDRANTS SHALL COMPLY WITH THE REQUIREMENTS OF AWWA C502 FOR DRY BARREL FIRE HYDRANTS WITH 6" INLET CONNECTIONS, TWO (2) 2 1/2" OUTLET NOZZLES, AND ONE (1) 5 1/4" PUMPER NOZZLE. WEEP HOLES SHALL NOT BE PLUGGED AND SHALL BE BACKFILLED WITH PEAS GRAVEL FOR ADEQUATE DRAINAGE. A 6" WATCH VALVE SHALL BE PROVIDED FOR EACH HYDRANT (SEE VALVE DETAIL FOR REQUIREMENTS). COLOR SHALL BE RED AND SILVER TO MATCH EXISTING HYDRANTS. ACCEPTABLE MANUFACTURERS ARE:

- 1) MCWANE (CLOW)
- 2) MUELLER
- 3) AMERICAN FLOW CONTROL
- 4) US PIPE AND FOUNDRY

| | | | |
|-------------------|---|---------------------------------------|----------------------|
| DATE: 06/09/18 |  | FIRE HYDRANT INSTALLATION STANDARD | DETAIL NO. 360--1 |
|-------------------|---|---------------------------------------|----------------------|

This Page Intentionally Left Blank

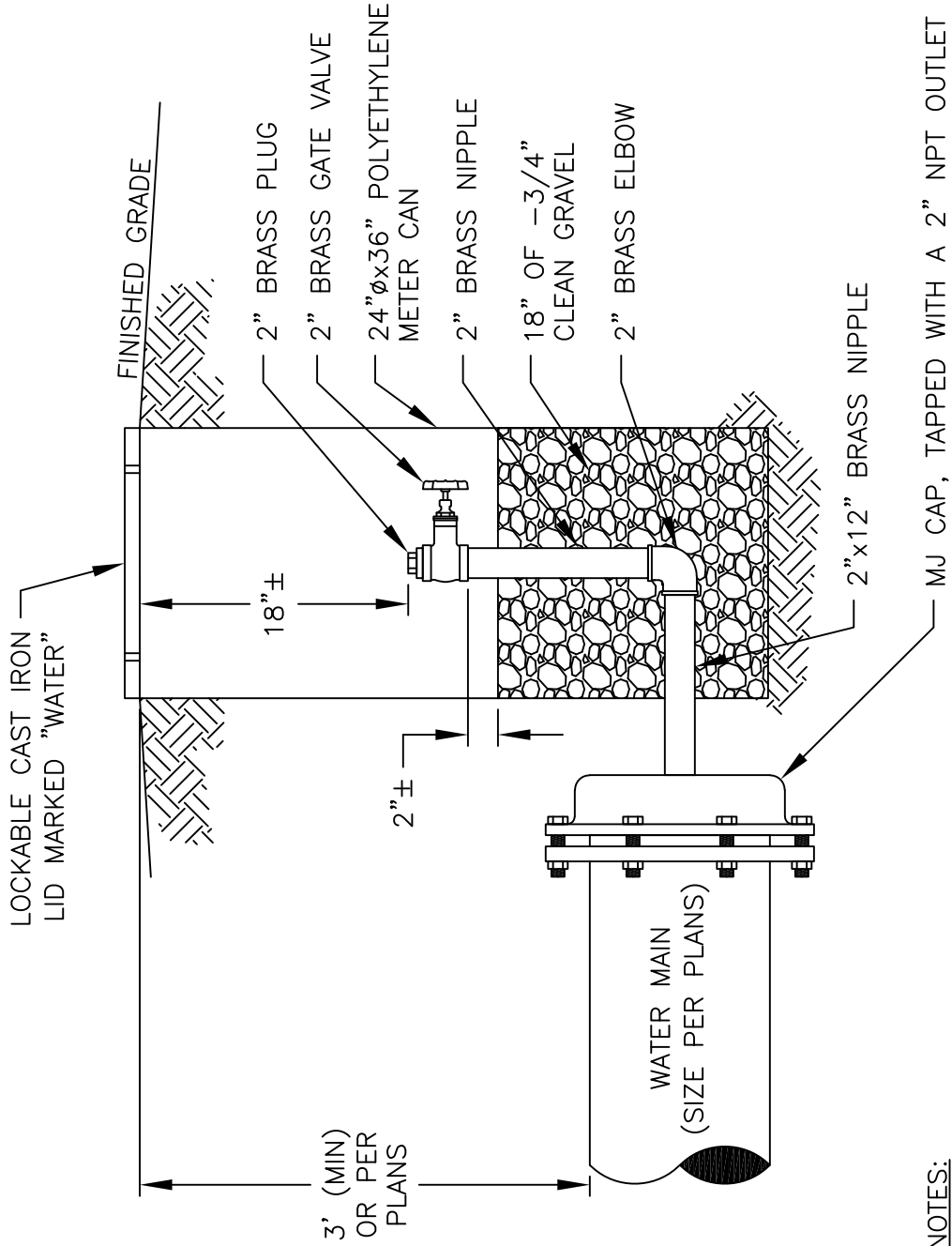

NOTES:

1. ALL BRASS FITTINGS TO BE NPT THREADED.
2. PLACE CAN 1" ABOVE FINISHED GRADE, AND PROVIDE POSITIVE DRAINAGE FROM LID.

DATE:

06/09/18



WASHOUT ASSEMBLY DETAIL

DETAIL NO.

360-2

This Page Intentionally Left Blank

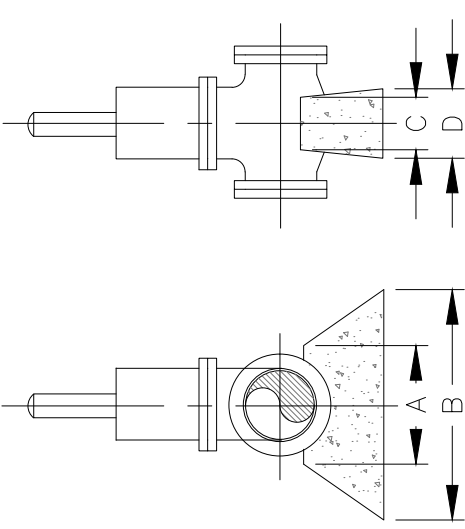

| VALVE SIZE | A | B | C | D |
|------------|-----|-----|----|----|
| 4" | 10" | 20" | 4" | 6" |
| 6" | 10" | 20" | 4" | 6" |
| 8" | 12" | 22" | 4" | 8" |
| 10" | 14" | 24" | 4" | 8" |
| 12" | 16" | 26" | 4" | 8" |

NOTES:

SHUTOFF VALVES SHALL COMPLY WITH THE REQUIREMENTS OF AWWA C509 FOR RESILIENT SEAT VALVES WITH DUCTILE IRON BODIES AND MECHANICAL JOINT ENDS.

ACCEPTABLE MANUFACTURERS ARE:

- 1) MCWANE (CLOW AND M&H DIVISIONS ONLY)
- 2) MUELLER
- 3) STOCKHAM VALVES AND FITTINGS
- 4) US PIPE AND FOUNDRY
- 5) WATEROUS
- 6) SLIP TYPE VALVE BOX SHALL BE FURNISHED (NOT SCREW TYPE) REFER TO SECTION 15131, PART 2 OF THE SPECIFICATION FOR SIZE OF VALVE BOX BASE
- 7) ACCEPTABLE MANUFACTURERS ARE:
 - 1) BRINGHAM & TAYLOR
 - 2) HANDLEP INDUSTRIES
 - 3) QUALITY WATER PRODUCTS
 - 4) MUELLER
 - 5) A.Y. McDONALD
 - 6) CLAY AND BARLEY
 - 7) TYLER

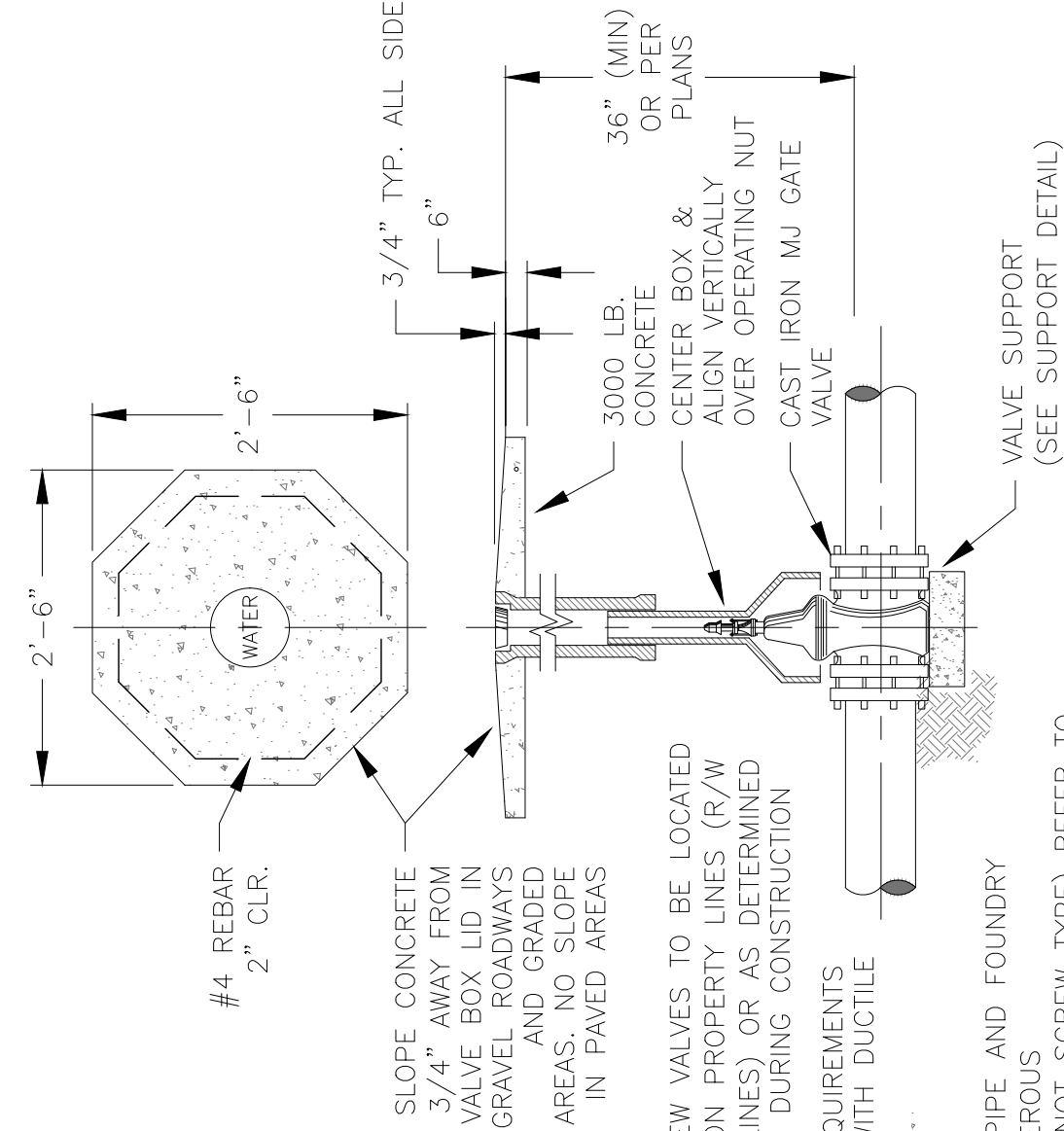

NEW VALVES TO BE LOCATED ON PROPERTY LINES (R/W LINES) OR AS DETERMINED DURING CONSTRUCTION

DATE:

06/09/18



VALVE AND BOX DETAIL

DETAIL NO.

360-3

This Page Intentionally Left Blank

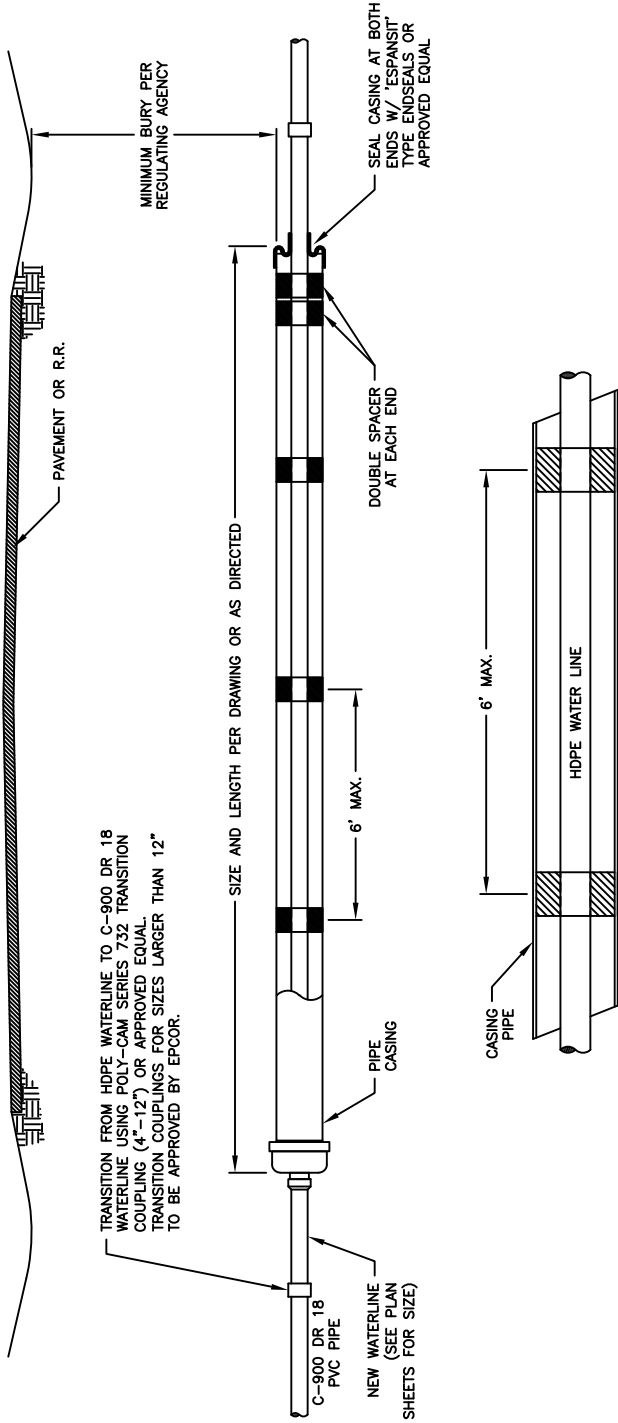

HIGH DENSITY POLYETHYLENE CASING SPACERS @ 6' MAX SPACING SHALL BE USED TO INSTALL THE CARRIER PIPE INSIDE THE ENCASEMENT PIPE. SPACERS SHALL BE OF A PROJECTION TYPE THAT HAS A MINIMUM NUMBER OF PROJECTIONS AROUND THE CIRCUMFERENCE TOTALING THE NUMBER OF DIAMETER INCHES.

| CASING OUTSIDE DIAMETER (IN) | HIGHWAY CROSSINGS CASING WALL THICKNESS (IN) | RAILROAD CROSSINGS CASING WALL THICKNESS (IN) | CASING OUTSIDE DIAMETER (IN) | HIGHWAY CROSSINGS CASING WALL THICKNESS (IN) | RAILROAD CROSSINGS CASING WALL THICKNESS (IN) |
|------------------------------|--|---|------------------------------|--|---|
| 8.625 | 0.250 | 0.250 | 30 | 0.375 | 0.469 |
| 10.750 | 0.250 | 0.250 | 36 | 0.500 | 0.532 |
| 12.750 | 0.250 | 0.250 | 42 | 0.500 | 0.563 |
| 14 | 0.250 | 0.281 | 48 | 0.625 | 0.625 |
| 16 | 0.250 | 0.281 | 54 | 0.625 | 0.688 |
| 18 | 0.250 | 0.312 | 60 | 0.625 | 0.750 |
| 20 | 0.312 | 0.344 | 66 | 0.625 | 0.813 |
| 24 | 0.312 | 0.406 | 72 | 0.750 | 0.875 |

NOTE:
 1. CASING PIPE SHALL BE BARE WALL STEEL PIPE WITH A MINIMUM YIELD STRENGTH OF 35,000 PSI WITH A MINIMUM WALL THICKNESS AS LISTED ABOVE.
 2. SMOOTH WALL STEEL PLATES WITH A NOMINAL DIAMETER OF OVER 54 INCHES SHALL NOT BE PERMITTED.
 3. THE INSIDE DIAMETER OF THE CASING PIPE SHALL BE AT LEAST TWO (2) INCHES GREATER THAN THE OUTSIDE DIAMETER OF THE CARRIER PIPE JOINTS OR COUPLINGS FOR CARRIER PIPE LESS THAN SIX (6) INCHES IN DIAMETER. THE INSIDE DIAMETER OF THE CASING PIPE SHALL BE AT LEAST FOUR (4) INCHES GREATER THAN THE OUTSIDE DIAMETER OF THE CARRIER PIPE JOINTS OR COUPLINGS FOR CARRIER PIPE SIZE SIX (6) INCHES AND OVER.

DATE: 06/09/18

EPCOR WATER

CASING DETAILS

DETAIL NO. 360-4

This Page Intentionally Left Blank

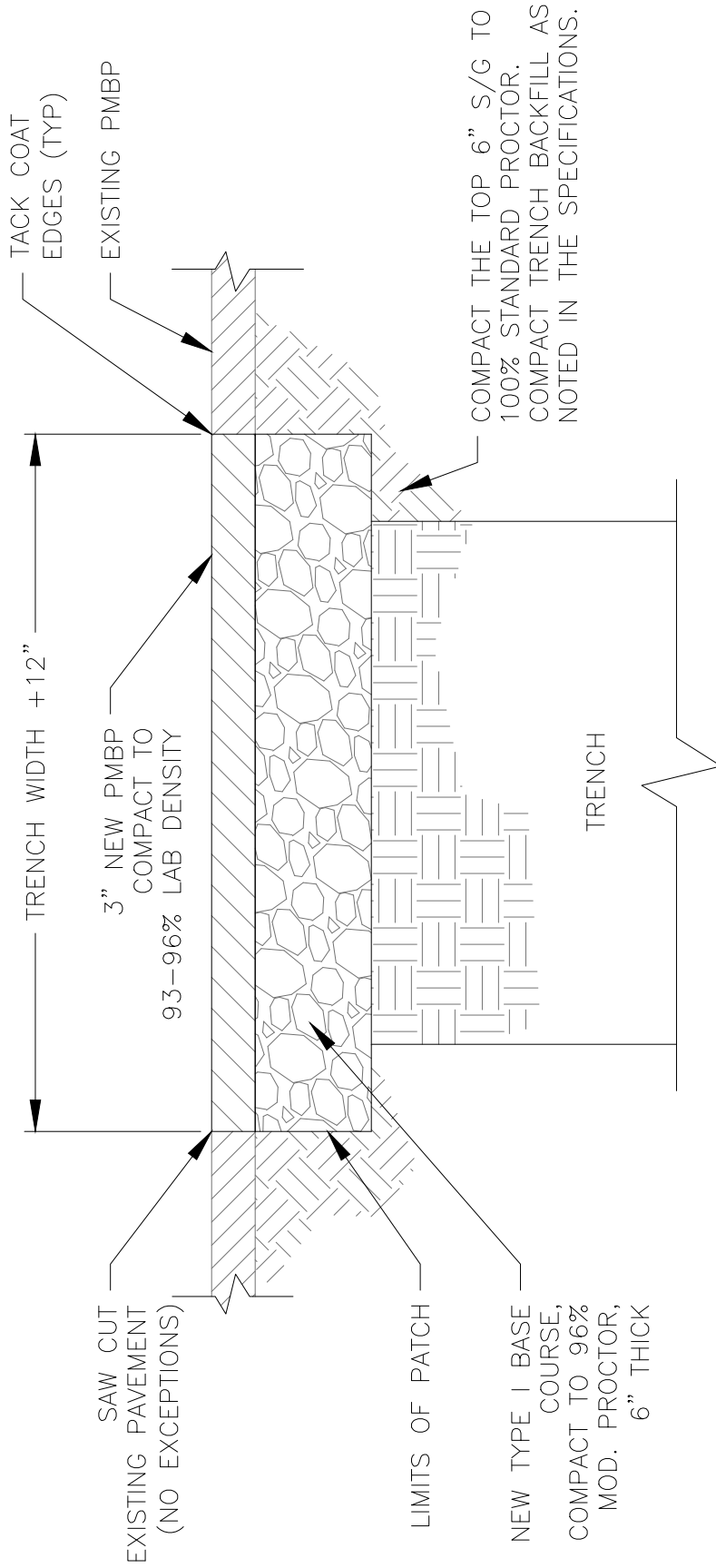

NOTES:

1. CONTRACTOR TO FURNISH, PLACE, AND COMPACT NEW PMBP AND BASE COURSE AS SHOWN.
2. CONTRACTOR TO TACK EDGES OF EXISTING PMBP W/ EMULSION.
3. CLEANUP AND DISPOSAL BY CONTRACTOR.

DATE:
06/09/18



PAVEMENT PATCH DETAIL

DETAIL NO.
360-5

This Page Intentionally Left Blank

MOUND CONCRETE
AFTER FILLING POST

4" SCH. 40 BLACK PIPE, 7' LONG,
FILLED W/ CONCRETE. PAINT POST
YELLOW AFTER CLEANING AND
PREPARING SURFACE.

3000 PSI CONCRETE

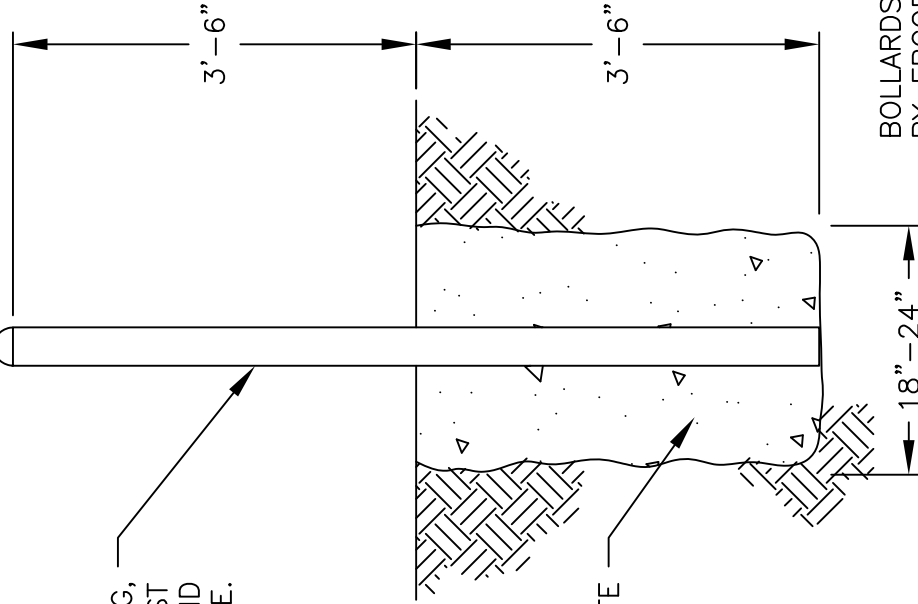

BOLLARDS TO BE PLACED AS DIRECTED
BY EPCOR TO PROTECT ABOVE GROUND
FACILITIES, IE. FIRE HYDRANTS, AIR
RELEASE VALVE VAULTS, ETC.

DATE:

06/09/18



WATER

TYPICAL BOLLARD DETAIL

DETAIL NO.

360-6

This Page Intentionally Left Blank

- NOTES:**
1. SEE PLAN FOR COMPONENT SIZES.
 2. INSTALL COMPONENTS PER MANUFACTURER'S INSTRUCTIONS.
 3. CONCRETE TO BE 3000 PSI.

VALVE SUPPORT TABLE

| VALVE SIZE | A | B | C | D |
|------------|-----|-----|----|----|
| 4" | 10" | 20" | 4" | 6" |
| 6" | 10" | 20" | 4" | 6" |
| 8" | 12" | 22" | 4" | 8" |
| 10" | 14" | 24" | 4" | 8" |
| 12" | 16" | 26" | 4" | 8" |

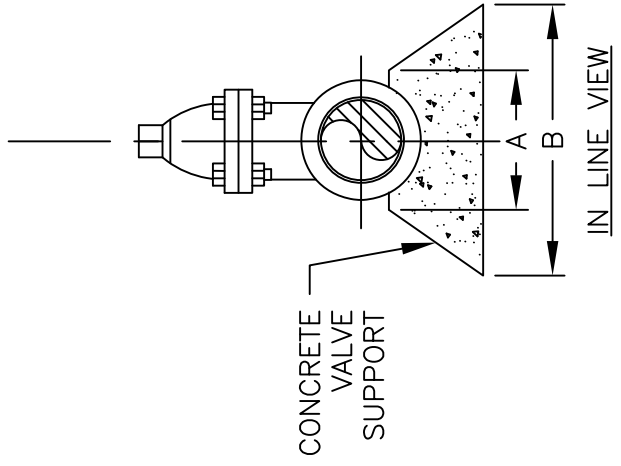
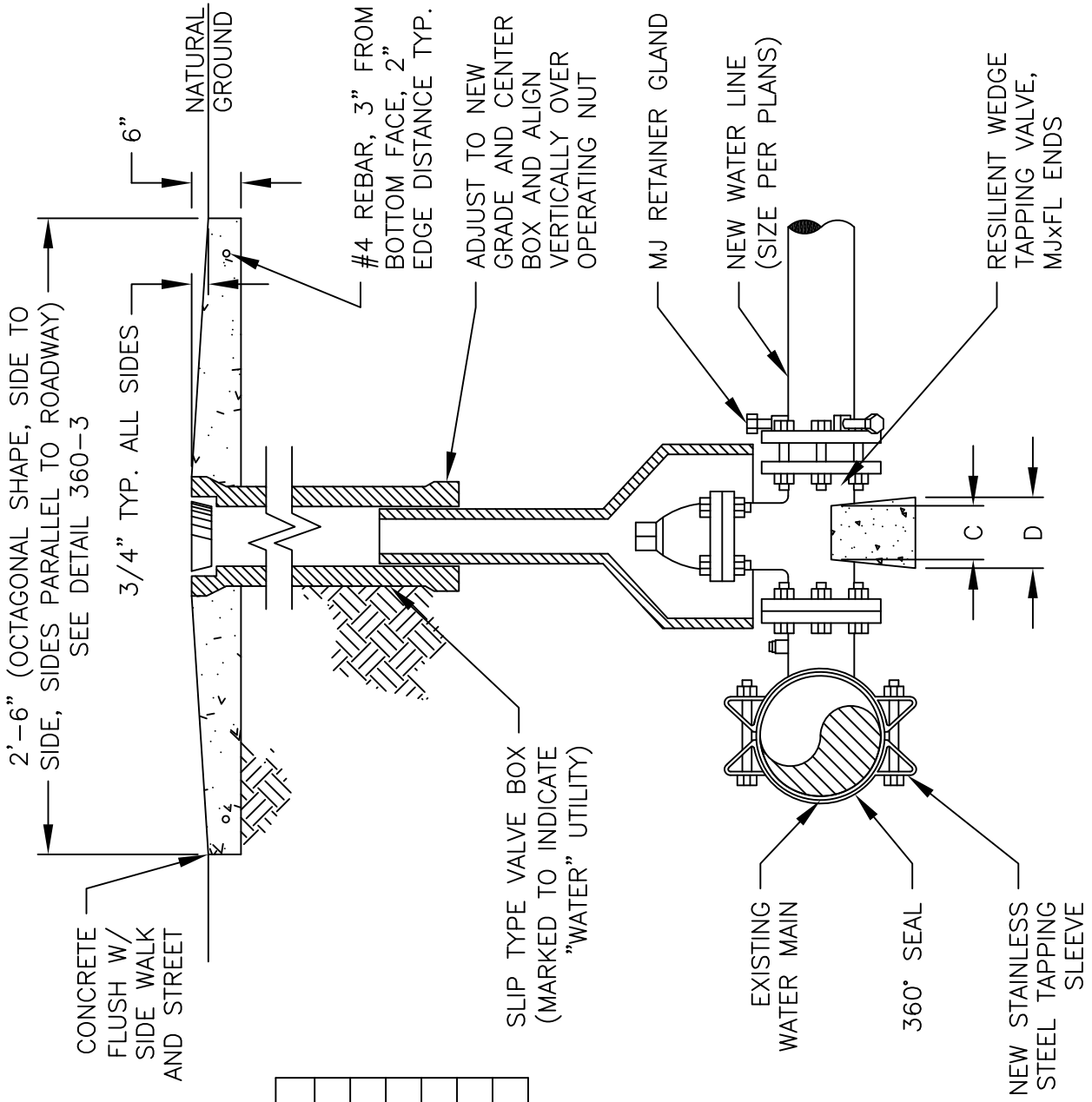

| | | | |
|-------------------|--------------------|-----------------------------------|---------------------|
| DATE: 06/09/18 | EPCOR WATER | TYPICAL HOT TAP CONNECTION DETAIL | DETAIL NO. 360-7 |
|-------------------|--------------------|-----------------------------------|---------------------|

This Page Intentionally Left Blank

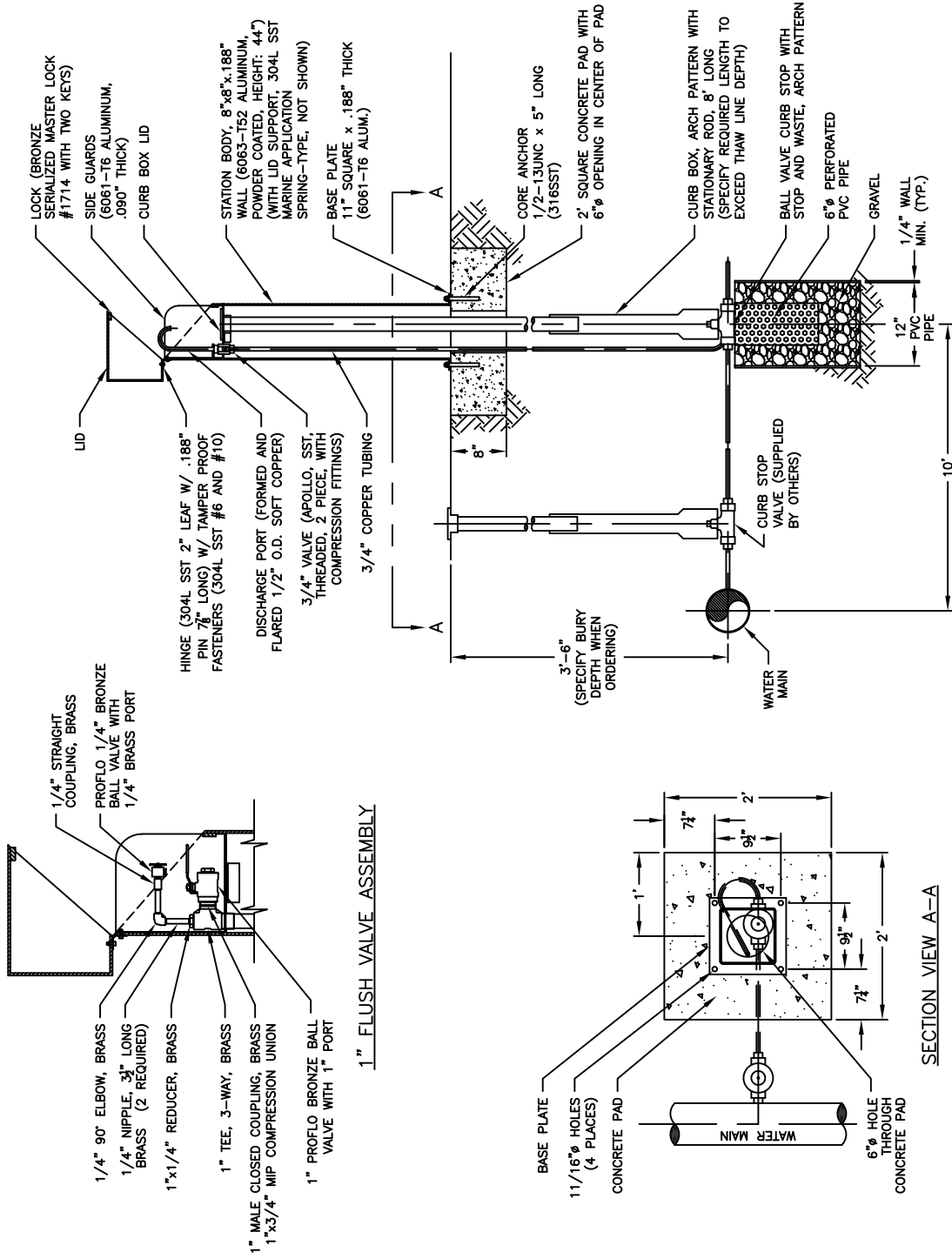

DATE:
06/09/18

WATER SAMPLING STATION
(AMERICAN MACHINE & CONVEYOR
CORP., MODEL EX-02-02FCW)



DETAIL NO.
390-1

This Page Intentionally Left Blank



APPENDICES



This Page Intentionally Left Blank



APPENDIX A

APPLICATION REQUIREMENTS FOR APPROVAL TO CONSTRUCT WATER FACILITIES



This Page Intentionally Left Blank



APPLICATION REQUIREMENTS FOR APPROVAL TO CONSTRUCT WATER FACILITIES

Minimum Requirements

- _____ Transmittal cover letter explaining request and listing attachments.
 - _____ Completed Application for Approval of Construction or Modification of Existing Public Water Supply System form.
 - _____ Engineered plans for review, sealed and signed (1 copy).
 - _____ Engineering plan review fee will be billed according to the Fee Schedule
- *** The Utility reserves the right to request any other information ***

APPLICATION INSTRUCTIONS

**** NO APPLICATION WILL BE ACCEPTED UNLESS FULLY COMPLETED.****

Project Name- must be the **same** as on the engineered plans.

Project Description- a description as you want it to appear on the Approval to Construct and/or Provisional Verification of General Permit Conformance for Water Facilities certificate.

Quantity of Waterline- total linear feet of lines by diameter.

Name of Project Engineer- Licensed engineer who is the person to contact for the project, must include phone number and email address.

Name of Project Engineer's Firm or Corporation- a licensed engineer firm that employees the project engineer, must include mailing address.

Applicant- must be a person with fiduciary responsibilities associated with the "Affiliation", if any.

Affiliation- examples: Project owner, Corporation, Home Owner Association, Municipality or any legal entity.

Title- examples: Owner, President or Vice-President of Corporation/Home Owner Association, City/Town Manager.

Mailing Address, City, State, Zip Code- location of applicant, **PO BOX IS NOT ACCEPTABLE.**



This Page Intentionally Left Blank



APPENDIX B

NMED DRINKING WATER BUREAU APPLICATION FOR CONSTRUCTION OR MODIFICATION OF A PUBLIC WATER SUPPLY SYSTEM



This Page Intentionally Left Blank



SAMPLE

**New Mexico Environment Department
 Application for Construction or Modification of a Public Water Supply System**

Date of Application: _____ Proposed Construction Start Date: _____
 (Check 20.7.10.201.K NMAC for Response Times)

If this application is for an existing water system, please include the Water System ID (WSS #): NM35_____

If this application is for a new* water system or conversion of an existing system to a public water system, please fill out and attach Appendix A. Appendix A does not apply to active water systems in the NMED inventory. Please consult <https://dww.water.net.env.nm.gov/DWW/>.

Please consult the citations to the New Mexico Drinking Water Regulations, <http://164.64.110.239/nmac/parts/title20/20.007.0010.pdf>, when responding to the following questions.

1. Is the application for a project described in 20.7.10.200.B NMAC? Yes¹ No
2. Is the application for a project described in 20.7.10.200.C NMAC? Yes² No
3. Is the application for a project described in 20.7.10.200.E NMAC? Yes³ No If responding "Yes" to Question 3 please submit the approval letter from the New Mexico Environment Department Drinking Water Bureau.

Public Water System Information

Consulting Engineer Information (P.E. Registered in New Mexico)

| | |
|-------------------------|-------------------------|
| System Name: _____ | Name: _____ |
| Contact: _____ | Company: _____ |
| Address: _____ | Address: _____ |
| City, State, Zip: _____ | City, State, Zip: _____ |
| Phone/Fax: _____ | Phone/Fax: _____ |
| Email: _____ | Email: _____ |

Public Funding: Will state or federal grant or loan funds be used to complete this project? Yes No
 List the NMED Construction Programs Bureau contact for publicly funded projects _____

Project Impact: (Please check all that apply)

- | | | |
|---|---|--|
| <input type="checkbox"/> A Supply Source | <input type="checkbox"/> B Treatment | <input type="checkbox"/> C Storage |
| <input type="checkbox"/> D Transmission | <input type="checkbox"/> E Distribution | <input type="checkbox"/> F Disinfection |
| <input type="checkbox"/> G Pumps (booster or transfer) | <input type="checkbox"/> H Backflow Prevention | <input type="checkbox"/> I Meter Installation |
| <input type="checkbox"/> J New or Converted System | <input type="checkbox"/> K Other (explain) | |

Project Summary (Do not exceed space provided): (Qty, size, linear footage, and type – as related to above impact)

I, the undersigned, a responsible officer or representative of the applicant, certify that, to the best of my knowledge, the information stated in this application together with the associated plans, specifications and other information give a true and complete representation of the proposed construction or modification of the public water supply system.

Name: _____ Title: _____
 Signature: _____ Date: _____

¹ Notification is not required.
² Notification is required. Approval is not required.
³ Approval is contingent upon certification by the applicant that the project conforms to 20.7.10.200.D.



SAMPLE



New Mexico Environment Department
Application for Construction or Modification of a Public Water Supply System

The application package for the project must be submitted prior to advertising the project for bid or entering into a construction contract if the project is not advertised for bid. The application will be reviewed within the applicable period stated in 20.7.10.201.K. A checklist is available on the Construction Link of the DWB Home Page, <https://www.env.nm.gov/dwb/construction/>, to ensure that the submittal is complete. Only electronic submittals to NMENV-DWBPlanReview@state.nm.us will be accepted to be reviewed for completeness. Incomplete applications will not be reviewed. The application package must contain:

1. **Application Form** – The “Application for Construction or Modification of a Public Water Supply System” must be submitted. The form must be completely filled out and signed. Department staff cannot make additions, deletions or changes to the form.
2. **Plans and Specifications** – A complete set of the plans and specifications must be submitted. The plans must be clear, legible and drawn to a scale that permits all necessary information to be shown without crowding. The plans must include a title page giving the name of the project, the owner of the public water supply system and the design engineer. The plans must include a location map for the project and a general layout of the facilities to be constructed. Detail plans should consist of plan views, elevations, sections, supplementary views and schematic diagrams as may be needed for construction of the proposed project.

The specifications must specifically cover the proposed project. The specifications must include all construction information not shown on the plans which is necessary to inform in detail the requirements for quality of material, workmanship and fabrication of the project.

Plans and specifications for public water supply system projects must be prepared under the direction of a professional engineer certified to practice in the State of New Mexico. Plans and specifications cannot be accepted for review by Department staff unless the engineer responsible for the design of the project has affixed his/her seal to the plans and specifications.

3. **Engineering Design Summary** – An engineering design summary must be submitted. An engineering design summary must include engineering information as required to set out the basis of the design of the proposed project. The engineering design summary must be in sufficient detail to allow Department staff to review the plans and specifications with regard to minimum design criteria, recognized public health and sanitary engineering practices and regulatory requirements.
4. **Disinfection and Sampling Plan** – A disinfection and sampling plan must be submitted. The plan must address disinfection of the system and sampling for the presence of bacterial contamination following completion of the project and prior to providing water to the public. The plan should include the method and scope for disinfection, a bacterial sampling plan which addresses the number of samples to be taken, the location(s) of sampling, and a contingency plan in the event bacterial sampling shows bacterial contamination. The plan should address the entire construction project and associated impacts to existing water system components, if any. The criteria used for review by Department staff include the American Water Works Association (AWWA) Standards for Disinfection and all references as listed in NMDWR 20.7.10.104. Additionally, the plan should include samples specified in NMDWR 20.7.10.201.E(2) to be collected from any new water sources that are part of the project as part of the source development. The list of required samples is available at https://www.env.nm.gov/dwb/construction/documents/RequiredSamplingNewSource_Contaminants_FEB2016.pdf
5. **Inventory of Contamination Sources** – For new wells or water sources only, an inventory of contamination sources must be submitted. The submittal should contain a physical inventory of existing and planned facilities and land uses that are actual or potential sources of contaminants of concern. The inventory must indicate the nature of the source and include the location of the contaminant source relative to the public water supply source. The location data can be provided in latitude/longitude format, state plane coordinates, or by distance and bearing, and can be absolute or relative to the public water supply source. The inventory must include the method used for collecting the location data. Specific requirements are given in NMDWR at 20.7.10.201.F for ground water sources and 20.7.10.201.G for surface water sources. The required land uses to be considered are available at <https://www.env.nm.gov/dwb/construction/documents/AppendixK.pdf>.

Submit your application to NMENV-DWBPlanReview@state.nm.us



SAMPLE



**New Mexico Environment Department
Application for Construction or Modification of a Public Water Supply System**

APPENDIX A

Additional Information Required for Projects involving the Construction or Activation of a New Public Water System: **Capacity Demonstration**

The NM Drinking Water Regulations (20.7.10.201.C NMAC) require any new public water system, defined as a newly-constructed public water system or an existing water system that is converted to a public water system, to submit documents that demonstrate sufficient technical, managerial, and financial capacity in their application to the Department.

Please submit the following documentation to the assigned Community Services Coordinator (CSC) 2 - 4 weeks BEFORE submitting this application in order to allow time for the capacity review. Applications submitted without the results of a completed capacity assessment, will be returned as incomplete. Please check the service area map online at https://www.env.nm.gov/dwb/assistance/documents/CapacityRegionsMap_Jan_2016.pdf, or call 1-877-654-8720 to request the contact information for the Community Services Coordinator assigned to your county. The assigned CSC can provide assistance with submitting the required documentation upon request.

Documents to be submitted:

1. Office of the Secretary of State Corporation Number (if applicable)
2. Articles of Incorporation, Bylaws, Rules, Regulations/Policies and Procedures for water system (if applicable)
3. Current Open Meetings Resolution (if applicable)
4. Job descriptions for all positions at water system
5. Annual water system budget or, if system does not charge for water service, a Water System Financial Plan
6. Water Rate and Fee Schedule (not required if system does not charge for water service)
7. Certification number of the operator(s) in responsible charge of water system
8. Operator contract (if system is operated by contract operator)
9. Operations and Maintenance Plan
10. Emergency Response Plan
11. Distribution System Sample Plan (DSSP) for distribution system contaminants
12. Source Water Assessment that identifies potential sources of source water contamination
13. If the new system is within one mile of an existing public water system, please provide documentation indicating why consolidation with that system is not a viable option. The location of all existing public water systems can be obtained from Drinking Water Watch at <https://dww.water.net.env.nm.gov/DWW/>.



This Page Intentionally Left Blank



APPENDIX C

NMDOT FORM No. A-063

APPLICATION FOR PERMIT TO INSTALL UTILITY FACILITIES WITHIN PUBLIC RIGHT
OF WAY



This Page Intentionally Left Blank



Form No. A-063
Rev. 2/19

SAMPLE

**APPLICATION FOR PERMIT TO INSTALL UTILITY FACILITIES
WITHIN PUBLIC RIGHT OF WAY**

TO: NEW MEXICO DEPARTMENT OF TRANSPORTATION
P.O. Box 1149
SANTA FE, NEW MEXICO 87504-1149

Permit No. _____
_____ Permit Renewal
_____ Relocation
_____ Remain in Place
_____ New Installation
_____ Out of Service

1. Pursuant to New Mexico Statutes Annotated, 1978 Compilation, Sections 67-8-13 and 55-2-7, and 17.4.2 NMAC the undersigned

Address: _____
herein makes application to use highway rights of way to install:

Size and Type of Facility _____

in the following location: N.M. Project No. _____ Route No. _____

Highway MP/GPS _____ to Highway MP/GPS _____

_____ County, Section _____, Township _____, Range _____

2. For the purpose of this application "within" shall be construed as meaning "on, upon, over, under, across or along."
- a. "Engineer" shall be construed as meaning the District Engineer of the New Mexico Department of Transportation of the District Engineer's Representative.
 - b. "Applicant shall be construed as meaning the individual, firm, corporation, association, governmental subdivision, or other organization making application, or the successors of any of the above.
 - c. "Facility" shall be construed as meaning, but not limited to any publicly, privately, cooperatively, municipally or governmentally owned facility used for carriage, distribution or transmission of water, gas or electricity, oil and products derived therefrom, sewage, stream or other projects carried by means of pipelines, conduits, wires, culverts, ditches, conveyors or other methods.
 - d. If application is for a parallel installation, justification as to why private right may be utilized must be furnished.

3. Applicant proposes to relocate install leave facility _____ feet within the _____ right of way line. The proposed installation shall be:

(Crossing or Parallel) (Subsurface or Overhead) (Boring, Jacking, or Pavement Cuts)

- a. If applicant requests installation by pavement cut, complete justification therefore shall be submitted by attachment.
- b. Where application for pavement cut is justified, the application may be held in abeyance pending receipt of cash bond in an amount to be fixed by the Engineer.

4. There is attached hereto a diagrammatic dimensioned drawing showing the location of existing and/or proposed installation referenced to roadway and right of way, right of way lines, any access control lines, distance of proposed installation above, or below grade, highway stationing, identification of materials to be used and any other pertinent data. If application is for parallel installation, nature of adjacent land use must be shown. Proposed installations on or in bridges or other structures, or for the installation of any structures, shall require detailed structural drawings.

5. Applicant desired this permit to be in effect for _____ years. Permit shall not be issued for a period longer than 25 years, and must be renewed upon expiration. The burden of timely renewal is on the Applicant. The Applicant shall formally notify the engineer of actual commencement and completion of construction of the installation. The Applicant shall also formally notify the Engineer of removal or abandonment of the facility, or relinquishment of the permit.

SAMPLE

Form No. A-063
Rev. 2/19

6. This application shall be validated as a permit upon the signing of the application by the Engineer and returned it to the Applicant. The granting of this permit shall not be construed as granting any easement of property right.
7. Servicing of facilities shall not be permitted within the access control lines on any controlled access project. Should an emergency occur, the Applicant shall notify the Engineer and shall provide such flagmen, flashers, warning or other safety devices as required by the Engineer. All routine maintenance shall be performed from outside any access control lines.
8. The relocation or installation of facilities within public right of way shall be in strict conformance with all **application provisions of regulations of the New Mexico Department of Transportation 17.4.2 NMAC**, all provisions of this application, drawing and the Instructions for Utility Permits, as they may be modified by the Engineer, and no departure therefrom may be made without the written consent of the Engineer. All facilities shall be so placed that they will not interfere with or endanger any roadway features or other existing facilities. All construction of facilities shall be subject to the inspection and approval of the Engineer. All such work shall be performed so that danger, inconvenience and delay to the traveling public will be held to a minimum. Protection and handling of traffic during the installation are the responsibility of the Applicant and must be approved by the Engineer.
9. The Applicant shall, except as otherwise ordered by the Engineer, restore the right of way, and all bridges or other structures thereon or adjacent thereto which have been altered or affected by facility installation performed hereunder, in accordance with sound construction practices and the Engineer's specifications, and shall cause the work to be done in a workmanlike manner, if any damage is caused to the highway right of way or to any bridge, structure or improvement thereon or adjacent thereto by reason of the design installation, maintenance alteration or removal of such facilities or other appurtenances, the Applicant shall reimburse the Engineer the full amount thereof promptly upon demand by the Engineer provided, however, that the obligation imposed under this paragraph shall not apply in the event the damage resulted from causes beyond the control of the Applicant or its contractors or its consultants. All such facilities located with the right of way shall at all times be kept in such repair so as not to damage the highway, inconvenience or endanger the traveling public and shall be kept free advertisement, posters and the like.
10. Should the Applicant at the time fail to promptly and fully perform any of the obligations imposed hereby and after thirty (30) days written notice thereof, the Engineer may, at his option (a) cause the obligations to be fully carried out and performed, and the Applicant shall promptly reimburse the Engineer for all costs and expenses incident thereto, or (b) summarily order the removal of such facility and if the Applicant fails to comply with that removal order within a reasonable time, the Engineer may direct the removal of the facility with all costs and expenses thereto to be borne by Applicant.
11. If by reason of any change in the location, construction, grade or by any other matter affecting the highway upon which any facility is located because of changing traffic conditions or otherwise, it shall become advisable in the opinion of the engineer that said facility be removed, relocated or otherwise modified, the utility, upon written notice from the engineer, shall provide all horizontal and vertical datum including pothole information, size and type of material, and condition of material. If necessary the utility shall remove, relocate or modify such facility without undue delay in such manner as the engineer may direct or approve, at the utility's expense and at no cost to the engineer. All facilities located on public right-of-way under the dual jurisdiction of the state and a subordinate governmental entity shall comply with all applicable rules and regulations of such entity properly and lawfully in force and including but not limited to provisions of local franchises not in conflict with the rules and regulations of the engineer. The engineer makes no warranty, either express or implied, as to the continued existence of any highway in any particular location and expressly assumes no obligation with regard to the facility upon change, vacation or abandonment of any highway or portions thereof.
12. Neither the making of this application nor anything herein contained shall constitute a waiver on the part of the Applicant of any rights or claims had or made by some with respect to the occupancy of the streets and highways under the Constitution and Laws of the State of New Mexico, nor shall anything herein contained in any prejudice or impair any rights or claims existing independent of this application with respect to the construction, operation, and maintenance of the Applicant's facilities in the State of New Mexico.
13. The utility owner must indemnify and hold harmless the New Mexico Department of Transportation from loss due to any negligent act of the utility, the utility's employees, any agent acting on the utility's behalf, and anyone else engaged by the utility to work on the utility installations, maintenance or relocations of their facilities. Any contractor or subcontractor engaged by the utility to perform utility installations or relocations in conjunction with or prior to highway construction must also indemnify and hold harmless the New Mexico Department of Transportation from loss due to any negligent act of the utility's contractor or subcontractor.
14. Each copy of the application shall be signed by the Applicant as an individual owner or by any official designated to execute such Documents.



SAMPLE

Form No. A-063
Rev. 2/19

15. Utility owners shall carry insurance in amounts not less than those below specified and as outlined in 17.4.2 NMAC and the Standard Specifications for Highway and Bridge Construction, 2019 Edition, (hereinafter, "Specifications"), as may be updated from time to time. In the event of conflict between the specification, and the regulations, owner shall carry the largest amount of insurance. If a utility is self-insured, the utility shall provide an Owner's Protective Liability Insurance Policy, in favor of the Department, in the amounts below specified. **Department as additional named insured:** The utility, contractor or subcontractor shall have the New Mexico Department of Transportation added as an additional named insured on the Comprehensive General Liability Form or Commercial General Liability Form furnished by the Utility.

This application is hereby granted subject to all provisions herein and including the following special provisions, changes or amendments:

The utility shall provide "as-built" horizontal and vertical location information in hard copy and electronic file (AutoCAD DWG (3D)). The standard horizontal datum shall be North American Datum 1983 (NAD83) and the standard projections shall be the New Mexico State Plane Coordinate System 1983 (NMSPCS83). The standard vertical datum shall be North American Vertical Datum 1988 (NAVD 1988). The utility location information shall be tied to Department monuments and referenced to highway mileposts and/or GIS coordinates and certified by a New Mexico Registered Land Surveyor. Metadata or "data about the data" shall be submitted with each utility's as-built electronic file, preferably as a separate text file on the electronic submittal media, and shall include: **1.** District Utility Permit Number. **2.** Name, address and phone number of the responsible land surveyor. **3.** Date of completion of survey. **4.** Equipment used to conduct the Survey. **5.** Horizontal and vertical control marks used to tie the survey to the NMSPC83 and NAVD88. **6.** Ground to Grid combined scale factor used. **7.** Elevations shall be provided every 500 feet and at all survey break points, including all high and low points.

Note: Highway projects are time sensitive therefore, permit information requested from Authorization to Engineer Letters must be returned by the date indicated within the Authorization to Engineer letter.

16. Any utility qualifying for reimbursement shall relocate in accordance with and pursuant to MAP-21; <http://www.fhwa.dot.gov/construction/contracts/buyam-qa.cfm> and (23U.S.C313)
Applicant/Utility Owner certifies we are in compliance with Buy America for said facility and agrees and understands non-adherence will void said permit.

Applicant _____

By _____

Title _____

Approval of this permit is hereby given this _____ day of _____, 20_____

NEW MEXICO DEPARTMENT OF TRANSPORTATION

By _____



This Page Intentionally Left Blank



APPENDIX D

NMDOT UTILITY PERMIT APPLICATION CHECKLIST



This Page Intentionally Left Blank

SAMPLE

Form No. A-63a
Revised 11/2014



UTILITY PERMIT APPLICATION CHECKLIST

This checklist is provided only as an aid to assist you in accurately developing a Utility Permit package for submittal. All the required forms, instructions, regulations will be provided to you upon request or upon authorization by the Department to Engineer and Design specific utility relocations on a highway construction project. More definitive information on the permit requirements is available in 17.4.2 NMAC.

1. Four fully executed Utility Permit Applications
 - All blank spaces on the Permit Application must be completely filled out (Project No. line may be left blank and milepost readings used in lieu of Stationing if your construction is not highway project related.)
 - Check appropriate box in upper right corner
 - Signature and title of owner or official designee
2. Include a Vicinity Map of the work area
3. Four ½ size (11x17) copies of Utility relocation/installation plans showing:
 - Title block with date, scale, county, north arrow and facility owner's name
 - Plan view of entire relocation/installation
 - Cross-section drawing of facility crossing the roadway
 - Profile drawing of facility paralleling roadway, including Right-of-Way lines
 - Right-of-Way lines, property lines, special existing field conditions/features
 - Right-of-Way width/dimensions

SAMPLE

Form No. A-63a
Revised 11/2014

- Dimensions from roadway centerline, edge of pavement and right of way line to facility
- Bore pit details, including distances from edge of pavement and right of way lines
- Highway stationing or Milepost readings
- Size and type of facility; Ex: 4" dia. PE water line inside 8" dia. X 120' steel casing (This same information should be shown on line 1 of the permit application.)
- Details of existing/proposed highway features affected by utility construction, if any.

NOTE: All of the above elements are also shown on our standard drawings. Highway Construction Plans may be used for your relocation plans as long as all the above elements are satisfied.

4. Other required Documentation:

- Copy of Archaeological & Environmental Clearances-

Contact: Gary Funkhouser, NMDOT Environmental Development Section in Santa Fe @ 505-827-5692

- Copy of Certificate of Insurance-must be in the amount of \$1,000,000 per occurrence during the project-with the NMDOT named as also insured
- Traffic Control Plan
- If disturbance is more than 1 acre: Proof of compliances with National Pollutant Discharge Elimination System (NPDES). Other approvals/authorizations/permits must be obtained and copies attached, from Indian, Federal and other State agencies where required.
- Proof of compliance with SWPP

NOTE TO APPLICANT: All of the above elements and information are required and reviewed when processing your permit package. The review of a permit normally requires up to forty (40) work days for completion. Please allow this amount of time when planning work schedules. Incorrect

SAMPLE

Form No. A-63a
Revised 11/2014

or missing information will only delay permit approval as the permit package will be returned for correction/completion. Please return this from with all items checked along with your executed and signed permit application.

EXHIBIT "A" UTILITY SURVEY DATA REQUIREMENTS

Within thirty (30) days of completion of the project, a set of hard copy as – built plans, stamped by a New Mexico Registered Land Surveyor are to be submitted to this office by the utility owner. The plans shall be plotted on NMDOT AutoCad DWG (3D) or Microstation DGN (3D) format. The standard horizontal datum shall be North American Datum 1983 (NAD 83) and standard projections shall be the New Mexico State Plane Coordinate System (NMSPCS 83). The Standard vertical datum shall be the North American Vertical Datum 1988 (NAVD 88). The preferred media in which this data must be submitted is CD-ROM; however, a 3.5" diskette may be used for the data submittal, if necessary.

The utility location information shall be tied to Department monuments and referenced to highway mileposts or to highway project construction stationing, and certified by a New Mexico Registered Land Surveyor. Metadata, or "data about the data" shall be submitted with each utility's as built electronic file, preferably as a separate text file on the electronic submittal media, and shall include:

1. District, Utility Permit Number
2. Name, address, and phone number of responsible land surveyor.
3. Date of completion survey
4. Equipment used to conduct the survey
5. Horizontal and vertical control marks used to tie the survey to the NMSPC83 and NAVD88. Ground to grid combination scale factor used.

Elevations shall be provided every 500 feet and at all survey break points, including all high and low points.

SAMPLE

Form No. A-63a
Revised 11/2014

The utility owner shall provide “as-built” horizontal and vertical utility location information in hard copy and electronic file in AUTOCAD DWG (3D) or MICROSTATION DGN (3D) format. The standard horizontal datum shall be the North American Datum 1983 (NAD83) and the standard projections shall be the New Mexico State Plane Coordinate System 1983 (NMSPC83). The standard vertical datum shall be the North American Vertical Datum 1900 (NAVD88). The preferred media in which this data must be submitted is CD Rom; 3.5: diskette may be used for the data submittal. The utility location information shall be tied to Department monuments and reference to highway mile post or highway project construction stationing, and certified by a New Mexico Registered Land Surveyor. Metadata or “data about the data” shall be submitted with each utility’s as-built electronic file, preferably as a separate text file on the electronic submittal media, and shall include:

1. District Utility Permit Number.
2. Name, address and phone number of the responsible land surveyor.
3. Date of completion of survey.
4. Equipment used to conduct the survey.
5. Horizontal and vertical control marks used to tie the survey to the NMSPC83 and NAVD88.
6. Ground to grid combined scale factor used.
7. Elevation shall be provided every 500 feet and at all survey break points, including all high and low points.



APPENDIX E

LINE EXTENSION AGREEMENT (LXA)



This Page Intentionally Left Blank



LXA No. _____

WATER LINE EXTENSION AGREEMENT

This WATER LINE EXTENSION AGREEMENT (this "Agreement") is made and entered into as of the _____ day of _____, 20____ by and between EPCOR Water New Mexico Inc., a New Mexico Corporation ("Company"), and _____ *Name of Developer* _____ *State of Registration* _____ *limited liability company ? corp?* located at _____ *Address* _____ ("Developer").

RECITALS:

- A. Developer _____ *description of development* _____ as described in **Exhibit "A"**.
- B. Company supplies water service to the _____ *name of development* _____ subject to regulation by the New Mexico Public Regulation Commission (the "Commission"). Company holds a Certificate of Convenience and Necessity issued by the Commission that authorizes Company to provide public water service to the _____ *name of development* _____.
- C. Developer desires to secure new water service to the _____ *location/project/development name* _____.
- D. Water service to the _____ *location/development* _____ will require certain improvements and additions to Company's water system.
- E. Developer and Company desire to enter into an agreement establishing their respective rights, duties and obligations with respect to the design, construction, and costs of the improvements, facilities, and additions necessary to supply water service to the _____ *development* _____.

NOW THEREFORE, in consideration of the foregoing recitals and the parties' mutual covenants, agreements and undertakings set forth herein, and for other good and valuable consideration the receipt of which the parties hereby acknowledge, Company and Developer hereby agree as follows:

1. **Construction of Line Extension.** Company agrees to construct, own, operate and maintain a 12-inch water line extension of approximately _____ feet (the "Extension") for the purpose of furnishing public water service to the _____ *development* _____. The Extension is described in greater detail in **Exhibit "B"**. Developer understands and agrees that the Extension excludes "service connection lines" to Developer's premises.
2. **Grant of Rights of Way, Easements.** Developer shall, at no cost to Company, and as a condition to Company's commencement of construction of the Extension, grant or cause to be granted to Company, perpetual rights-of-way and easements, each in a form reasonably satisfactory to Company's legal counsel, for Company's ownership, construction, operation, maintenance, replacement and removal of the Extension and Fire Hydrants. Each such easement shall be accompanied by an ALTA survey and real property title report reasonably satisfactory to Company's legal counsel.
3. **Payment by Developer.** As a condition to Company's commencement of any engineering or construction activities with respect to the Extension, Developer shall pay Company, as a refundable advance in aid of construction, the amount of \$ _____ (the "Advance"), which represents Company's estimate of the cost of engineering and constructing the Extension, as required for Company's delivery of water service to the _____ *development* _____. Developer also agrees to pay, as and when due, Company's standard connection charges and other tariff charges for "service connection lines" to Developer's premises.



LXA No. _____

Upon Company's completion of the engineering and construction of the Extension, Company shall tabulate Company's total costs of such engineering and construction for the Extension (the "Actual Cost"). If the amount of the Actual Cost for the Extension is less than the amount of the Advance, Company will promptly refund to Developer an amount equal to the difference between the Advance and the Actual Cost. If the Actual Cost for the Extension is greater than the amount of the Advance, Developer will promptly pay to Company an additional amount equal to the difference between the amount of the Actual Cost and the amount of the Advance.

4. Refunds to Developer. The Developer's costs and fees that are defined under this Agreement as a refundable Advance in aid of construction will be refunded by Utility to Developer as described in this paragraph. The amount to be refunded annually shall be ten percent (10%) of Utility's revenues (excluding all gross receipts taxes, sales taxes and district, municipal, county, state and federally imposed regulatory assessments) derived from the provision of water service to each consumer whose service line is directly connected to the Extension. Refunds shall be payable for a period of ten (10) years from the date of completion of construction of the Extension, but in no event shall the refunds paid to Developer exceed the Actual Cost paid by Developer as an Advance in aid of construction. Any unrefunded balance of such Advances remaining at the end of the applicable refund period shall become non-refundable. No interest shall be paid on any amount advanced by Developer.

5. Interconnections. Company has the right to, and may in the future, connect its existing or future water systems to the Extension, and Company has the right to add as many customers and make such extensions and additions to, or beyond, the Extension as may be necessary or desirable in Company's conduct of its water business. If Company elects to exercise its rights under this paragraph, Developer shall have no obligation under this Agreement to bear any costs relating to any resulting required replacement of the Extension, or any portion of the Extension, with larger water mains and lines.

6. Filing with the Commission. Upon execution of this Agreement by Developer and Company, Company shall file this Agreement with the Commission.

7. Indemnification. Developer indemnifies and holds Company, its officers, directors, agents, and employees harmless from and against all claims, damages, costs and expenses, including penalties and assessments, attorneys' fees and court costs, to which they or any of them may be subjected by reason of injury, death, loss, claim, penalty, assessment or damage caused or contributed to by the active or passive negligence of Developer, its agents, servants, employees, contractors or subcontractors in the execution of the work or in connection therewith. If any suit or other proceeding is brought on this account, Developer will assume the defense at Developer's expense and will pay all judgments rendered therein. The foregoing indemnity does not cover any negligent or wrongful acts of Company, its officers, directors, agents or employees.

8. Notices. All notices, requests, consents, directions and other instruments and communications required or permitted to be given under this Agreement shall be in writing and shall be deemed to have been duly given if delivered personally, if mailed first-class, postage prepaid, registered or certified mail, or if sent by electronic mail (followed with confirmation of receipt by telephone conversation), as follows:

If to Company:

EPCOR Water New Mexico Inc.
P.O. Box 370
Edgewood, NM 87015-0370
Attention: Tom Torres



LXA No. _____

If to Developer:

Attention: _____

or to such other address and to the attention of such other person(s) or officer(s) as any party may designate by written notice. Any notice mailed shall be deemed to have been given and received on the third business day following the day of mailing.

9. Assignment. Developer may not transfer, assign, pledge or hypothecate its rights, interests or obligations under this Agreement, without, in each instance, the prior written consent of Company.

10. Successors. This Agreement shall inure to the benefit of, be binding upon, and be enforceable by the parties hereto and their respective successors and assigns.

11. Entire Agreement. This Agreement constitutes the entire agreement and understanding between the parties relating to the subject matter of this Agreement and supersedes all prior representations, communications and arrangements, whether oral, written or inferred, between the parties relating to such subject matter. This Agreement may not be modified or amended, except upon a written instrument executed by a duly authorized representative of each of the parties hereto.

12. Governing Law; Jurisdiction and Venue. This Agreement, its interpretation, validity and the performance hereof shall be governed by and construed in accordance with the laws of the state of New Mexico, without giving effect to its conflicts of laws provisions.

13. Amendments and Waivers. This Agreement shall not be amended or modified except by a writing duly executed by Company and Developer. The waiver of any breach of any term or condition of this Agreement shall not be deemed to constitute the waiver of any other breach of the same or any other term or condition.

14. No Third Party Beneficiaries. Any agreement contained, expressed or implied in this Agreement shall be only for the benefit of the parties to this Agreement and their respective legal representatives, successors and assigns, and such agreements shall not inure to the benefit of any third party, it being the intention of the parties to this Agreement that no person or entity shall be deemed a third party beneficiary of this Agreement.

15. Counterparts. This Agreement may be executed in any number of counterparts, each of which shall be deemed an original, but all of which together shall constitute one and the same instrument.

16. Headings. The headings contained in this Agreement are intended solely for convenience and shall not affect the rights of the parties to this Agreement.

REST OF THIS PAGE INTENTIONALLY LEFT BLANK



LXA No. _____

IN WITNESS WHEREOF, the parties have duly executed and delivered this Agreement as of the day and year first above written.

EPCOR Water New Mexico Inc.

Signature: _____

Printed Name: _____

Title: _____

Date: _____

Developer _____

Signature: _____

Printed Name: _____

Title: _____

Date: _____



LXA No. _____

EXHIBIT A

Description of the project location



LXA No. _____

EXHIBIT B

Description of the Extension



APPENDIX F

RELEASE AND WAIVER OF LIEN



This Page Intentionally Left Blank



RELEASE AND WAIVER OF LIEN

MATERIALS AND/ OR LABOR

Date: _____

To Whom It May Concern: _____

(List your company name here)

The undersigned, having received payment in full for all labor, supplies, or equipment supplied to the

_____, the contractor or subcontractor, in the construction or repair of the improvements upon the property located at

and furnished in the execution and fulfillment of contract between _____
_____(contractor) and _____(owner), dated _____

_____, do (does) hereby release and waive any and all claims, liens and lien rights, of any kind, or description whatsoever, against said property and the Owner thereof, and against the Contractor.

Dated this _____ day of _____, 20____

Signature: _____

Date: _____

Printed Name: _____

Company: _____



This Page Intentionally Left Blank

